

MON-O-BAG® VOLUMETRIC SYSTEM - A fully automatic form-fill-seal system with a specially designed turret type continuous motion filler with five quick change volumetric cups. Volume adjustable during operation. (See Specification Index - Item 1.)

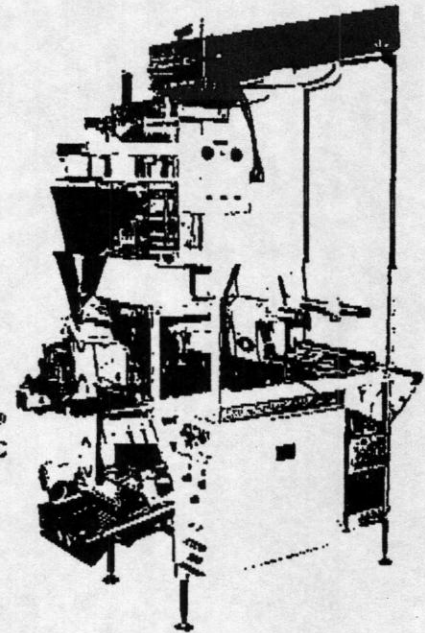

**MON-O-BAG®
VOLUMETRIC
SYSTEM**

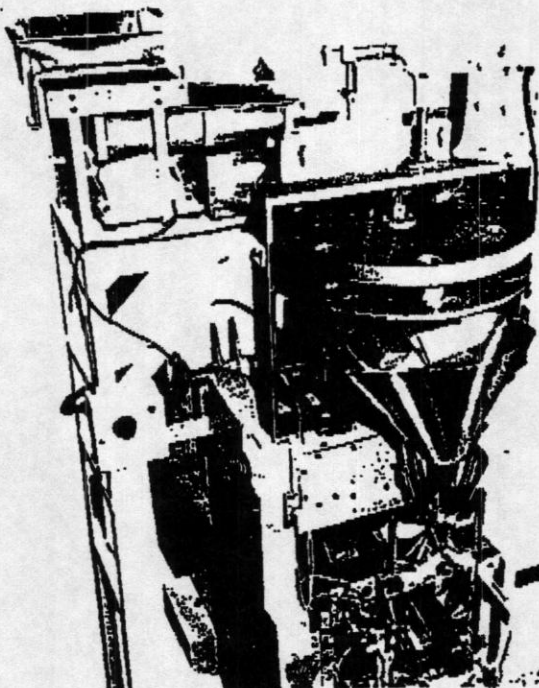

VOLUMETRIC SYSTEM VF6

A Wright Volumetric cup filler provides high-speed packing of popcorn, Rice, Pasta products, confectionery, dried vegetables, etc.

The filler is driven directly by the Monobag ensuring perfect synchronisation and maximum efficiency with speed up to 90 bags per minute. Two hopper versions are available, either a direct gravity feed for heavy granular products or a controlled vibratory feed for fragile products. A special model is available for polythene sealing with high-speed jaws capable of delivering 80 bags per minute.

FEATURES

- Precise synchronisation.
- System adjustable to compensate for varying product flow characteristics.
- Volumetric cups adjustable up to 40% in volume.
- Speeds up to 90 bags/min.
- Low product drop to minimise damage to product.

FIG. 1

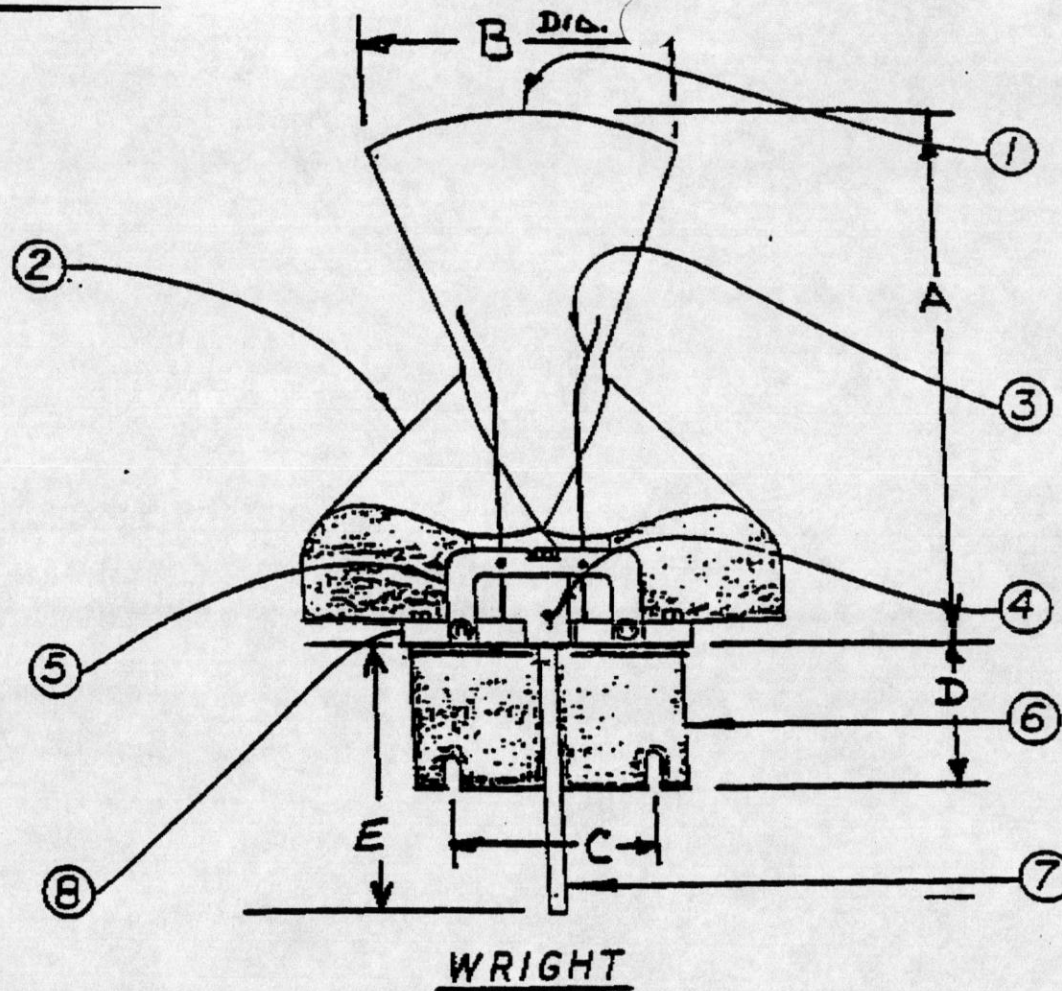

WRIGHT MODELS

918-shown
 1018
 1222

① — TRANSITION FUNNEL

② — FORMER

③ — TRANSITION RODS

④ — TUBE OVERLAP

⑤ — YOKE

⑥ — WRIGHT MOUNTING PLATE

⑦ — TONGUE

⑧ — FORMER BASE PLATE

A	
B	
C	
D	
E	