



PER Series 3 Electric-Hydronic Boilers

Installation Instructions



Installer

WARNING

Read all instructions before installing. Follow all instructions in proper order to prevent personal injury or death.

- Consider piping and installation when determining boiler location.
- Any claims for damage or shortage in shipment must be filed immediately against the transportation company by the consignee.

WARNING

These Instructions must be used only by a qualified installer/service technician. Read these instructions completely before beginning. Failure to follow these instructions can cause severe personal injury, death or substantial property damage.

NOTICE

When calling or writing about the boiler— Please have the boiler model number from the boiler rating label and the CP number from the boiler jacket. You may list the CP number in the space provided on the Installation and service certificate found on page 9.

User

- This manual is for use only by your qualified heating installer/service technician.
- We recommend regular service by a qualified service technician, at least annually.





Please read before proceeding

Hazard Definitions

The following defined terms are used throughout these Instructions to bring attention to the presence of hazards of various risk levels, or to important information concerning the life of the product.

DANGER

Indicates presence of hazards that will cause severe personal injury, death or substantial property damage.

WARNING

Indicates presence of hazards that can cause severe personal injury, death or substantial property damage.

CAUTION

Indicates presence of hazards that will or can cause minor personal injury or property damage.

NOTICE

Indicates special instructions on installation, operation or maintenance that are important but not related to personal injury or property damage.

WARNING

Failure to adhere to the guidelines on this page can result in severe personal injury, death or substantial property damage.

When servicing boiler —

- To avoid electric shock, disconnect electrical supply before performing maintenance.
- To avoid severe burns, allow boiler to cool before performing maintenance.
- The boiler contains fiberglass materials. Use care when handling these materials per instructions on page 11 of this manual.

Boiler operation —

- Do not block flow of ventilation air to boiler. Will cause components to overheat.
- Should overheating occur, do not disconnect electrical supply to circulator. Instead, shut off the electrical supply at a location external to the appliance.
- Do not use this boiler if any part has been under water. Immediately call a qualified service technician to inspect the boiler and to replace any part of the control system that has been under water.

Boiler water —

- Do not use petroleum-based cleaning or sealing compounds in boiler system. This can result in substantial property damage.
- Do not use "homemade cures" or "boiler patent medicines". Serious damage to boiler, personnel and/or property may result.
- Continual fresh makeup water will reduce boiler life. Mineral buildup in section reduces heat transfer, overheats cast iron, and causes section failure. Addition of oxygen and other gases can cause internal corrosion. Leaks in boiler or piping must be repaired at once to prevent makeup water.
- Do not add cold water to hot boiler. Thermal shock can cause sections to crack.

Glycol — potential fire hazard —

All glycol is flammable when exposed to high temperatures. If glycol is allowed to accumulate in or around the boiler or any other potential ignition source, a fire can develop. In order to prevent potential severe personal injury, death or substantial property damage from fire and/or structural damage:

- Never store glycol of any kind near the boiler or any potential ignition source.
- Monitor and inspect the system and boiler regularly for leakage. Repair any leaks immediately to prevent possible accumulation of glycol.
- Never use automotive antifreeze or ethylene glycol in the system. Using these glycols can lead to hazardous leakage of glycol in the boiler system.



Pre-installation

General instructions

The Weil-McLain Model PER electric-hydronic boilers are assembled units designed for use in forced hot water heating systems. The suggested design temperature rise through the boiler is 20°F. The PER boiler is a complete package including the circulator and expansion tank.

Low flow rates through the boiler at elevated temperatures should be avoided. The structure to be heated should be insulated in the conventional manner used in your area for electrically heated buildings. Boiler must be installed in accordance with these instructions so as not to void our warranty.

Open the boiler crate and check the contents. In the event of shortage or damage, notify the transportation company immediately.

Locating the boiler

The compact construction of the electric-hydronic boiler permits installation in an alcove, storeroom or other small area. The location chosen should have convenient electrical service.

Allow sufficient clearance above and below the boiler cabinet to permit installation of supply and return piping. A minimum of 6 inches is required at the top of the boiler for installation and accessories. A clearance of 10 inches is required on the right hand side for removal of the elements.

Mounting the boiler

Normally, the boiler will be installed against a frame or masonry wall. If the wall surface is rough or uneven, it may be necessary to mount plywood on the wall, then mount the boiler on the plywood. Refer to "Dimensions" on page 12 and "Ratings" on page 13, and note the boiler weight. Be sure that the wall structure will support the boiler and its piping.

The 9/16" top mounting holes and 5/16" lower mounting holes are on 16-inch centers to permit installation on studs in standard wall construction. The use of 1/4" x 2 1/2" lag screws is recommended for mounting the boiler. The head diameters of the top two screws must not exceed 9/16".

1. Locate the top mounting holes so that the boiler will be level. Install the screws so that the heads protrude 3/4" from the wall.
2. Raise the boiler to mounting position by placing a board across the bottom of the boiler or by grasping the lower left and right inside corners. Do not attempt to lift the boiler by grasping the bottom jacket cross tie.
3. Place the top brackets over the lag screws and then install screws through the lower mounting holes. The top screws can now be tightened.

Expansion tank sizing

CAUTION

Undersized expansion tanks cause system water to be lost from relief valve and makeup water added through fill valve. Eventual section failure can result.

If a Fill-Trol system is used, refer to Table 1 for proper sizing. If Fill-Trol action is not desired, size the expansion tank according to the water volume of the system. If a standard closed expansion tank (without a diaphragm) is used, the air vent tapping on the boiler casting makes a convenient point of connection. The No. 109 Fill-Trol is furnished as standard equipment.

Table 1 Expansion tank sizing (Tank sizing based on 200 °F average system temperature.)

Boiler model number	Standard Fill-Trol tank (for series loop or one-pipe system with convector baseboard)	Additional Ex-Trol tank (for cast-iron radiators or cast-iron baseboard)
PER-15	No. 109	No. 15
PER-20	No. 109	No. 15
PER-25	No. 109	No. 15

Note: Gravity systems converted to a forced hot water system usually require additional compression tank capacity.

Hydrostatic pressure test

Pressure test boiler before attaching piping or electrical supply.

1. Install air vent in tapping on top of boiler.
2. Plug remaining tappings, including relief valve opening.
3. Connect water supply. Fill boiler and purge all air. For more than 10 minutes, pressure-test at 1 1/2 times maximum working pressure.

WARNING

Do not leave boiler unattended. Cold water fill could expand and cause excess pressure, resulting in severe personal injury, death or substantial property damage.

4. Check for maintained gauge pressure. Visually check for leaks if gauge pressure drops.
5. Drain boiler and repair leaks if found.

WARNING

Leaks must be repaired at once. Failure to do so can damage boiler, resulting in substantial property damage.

6. Retest boiler after repairing leaks.
7. Remove testing plugs and air vent.

DANGER

Do not use petroleum-based cleaning or sealing compounds in boiler system. Severe damage to boiler will result, causing substantial property damage.



Pre-installation continued

Piping the boiler

After the boiler is secured to the wall, attach the supply and return piping. Refer to Table 2 for minimum pipe sizes.

Install manual shut-off valves in the supply and return lines to facilitate servicing the boiler. Model PER boilers are provided with a built-in air elimination system using a float-type automatic air vent. Refer to the boiler line drawings and proceed as follows:

1. Install the pressure-temperature gauge and 3/4"-1/4" bushing in the 1 1/4" x 1 1/4" x 3/4" tee installed on the boiler supply connection. See "Dimensions" on page 12.
2. The 3/4" tapping, located to the left of the supply tapping, must be used for either an automatic venting device or piped directly to a standard closed expansion tank.
3. Install the pressure relief valve in the 3/4" tapping located on the top left hand side of the boiler (see "Dimensions" on page 12). Pipe the relief valve outlet to a floor drain or near the floor. Do not pipe the relief valve to any area where freezing temperatures might be encountered.

WARNING Pipe relief valve discharge line near floor close to floor drain to eliminate potential of severe burns. Do not pipe to any area where freezing could occur. Do not plug valve or place any obstruction in discharge line.

4. Connect the system supply piping to the tapping located at the right on the top of the boiler casting.
5. Connect the system return piping to the circulator flange. When solder fittings are used, be sure that the gasket is not between the flanges when the solder connection is made.
6. A Fill-Trol system is supplied with PER boilers follow the instructions attached to the valve.

Wiring the boiler

WARNING Electric shock hazard. Can cause severe personal injury or death if power source, including service switch on boiler, is not disconnected before installing or servicing.

The Model PER electric-hydronic boilers are pre-wired for use with 240-volt, single phase, 50/60-hertz power. Refer to Figure 1 on page 13 for the reduction in boiler capacity when the line voltage is less than 240 volts.

An opening is provided in the left side of the jacket top panel for the field wiring. Refer to Dimensions, page 12, and Ratings, page 13, for recommended wire sizes.

All wiring must conform to the requirements of the National Electrical Code and any additional National, State or Local Code Requirements having jurisdiction. All safety circuit wiring should be N.E.C. Class 1. Do not use aluminum wire.

When a PER boiler is used in a zoned system, the zone valves must be powered from an independent source, and have electrically isolated end switches or isolating relays wired in parallel to the boiler thermostat terminals.

NOTICE Do not attempt to power zone valves from the transformer in the boiler control system.

Control system

The control system for the PER electric boiler has electronic and thermal time delays, which are employed to sequence elements on and to sequence elements off in reverse order. The contactors used in the system disconnect all current from the heating elements.

The circulator control utilizes a single pole relay. Low and high limit functions are combined in a dual limit control. The control system is operated from a low voltage transformer.

Table 2 Pipe sizes and flow rates
(Recommended minimum pipe size with 20°F temperature rise through boiler.)

Boiler model number	Maximum flow rate GPM	Minimum supply pipe size	Minimum return pipe size
PER-15	5.20	3/4"	3/4"
PER-20	6.90	1"	1"
PER-25	8.60	1 1/4"	1 1/4"



Sequence of operation

Call for heat

1. The thermostat contacts close, energizing the first contactor (2K), the circulator relay (1K), and the heater in the first thermal time delay (H1).
2. Approximately 15 seconds later, the thermal delay contacts (1C) close energizing the electronic circuit inside the first electronic time delay (ED1).
3. After approximately 2.5 minutes, the first electronic time delay energizes the second contactor (3K) and the second thermal time delay heater (H2).
4. This sequence continues until all contactors are energized or until the call for heat ends.

Call for heat satisfied

5. The thermostat contacts open, de-energizing the first contactor (2K), the circulator relay (1K), and the heater in the first thermal time delay (H1).
6. After a minimum of 10 seconds, the contacts in the first thermal delay (1C) open, instantly de-energizing the electronic time delay (ED1), the second contactor (3K), and the second thermal delay heater (H2).
7. This sequence continues until all elements are de-energized.

Limit control operation

8. If the high limit setting is exceeded, the transformer secondary circuit is opened and all contactors are de-energized instantly. It is recommended that the “high” side of the control be set at 220°F. The “low” side should be set according to the design requirements of the structure to be heated but never less than 20°F below the “high” setting. The differential control should be set at a minimum of 20°F.



Wiring

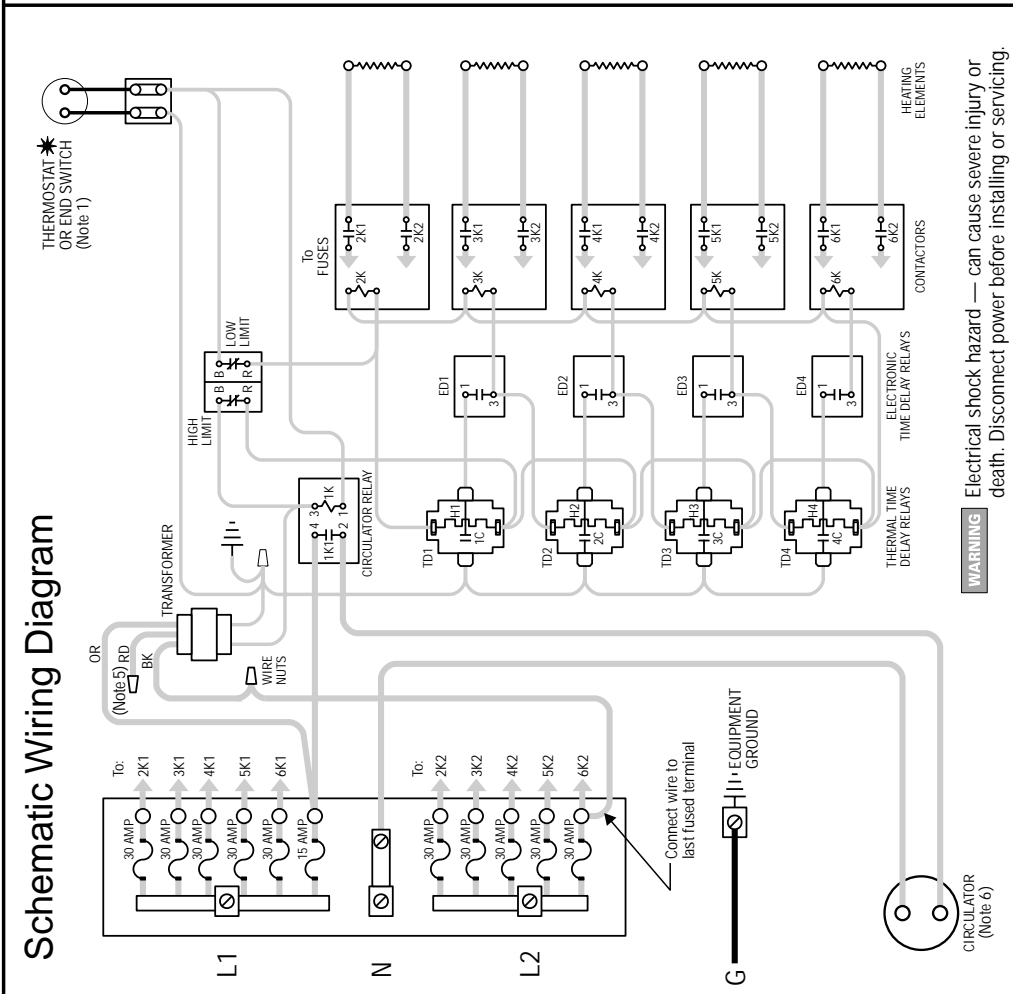
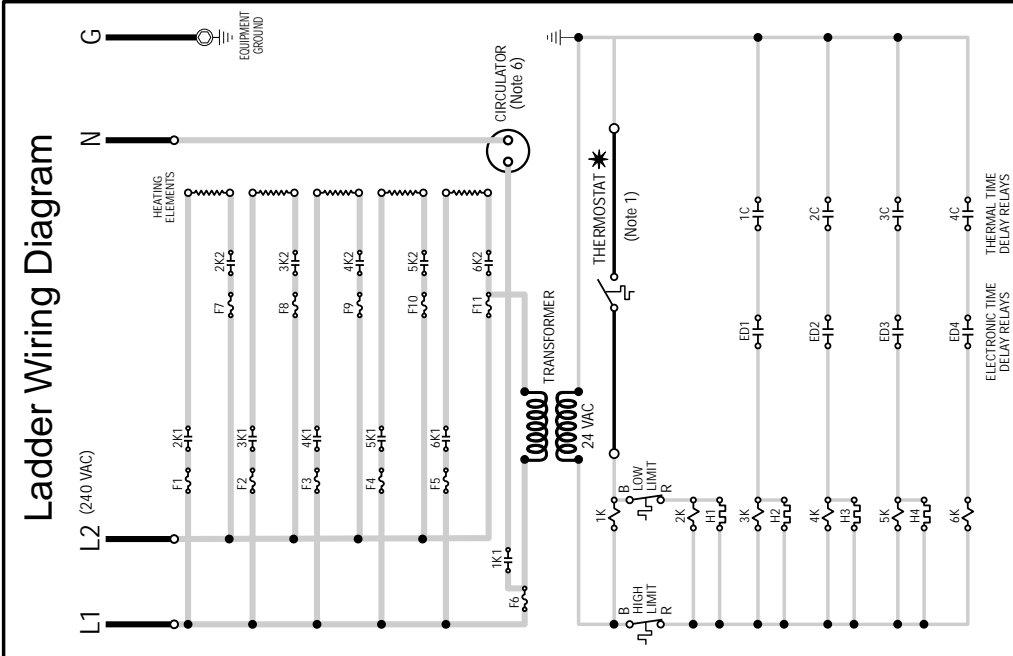

Legend

- HIGH VOLTAGE FIELD WIRING
- HIGH VOLTAGE FACTORY WIRING
- LOW VOLTAGE FIELD WIRING
- LOW VOLTAGE FACTORY WIRING

* Items not provided

Notes:

1. Thermostat heat anticipator setting must be 0.45 amps.
2. All wiring must be installed in accordance with the requirements of the National Electrical Code and any applicable national, state or local code requirements.
3. All safety circuit wiring must be N.E.C. Class 1.
4. Use only copper conductors for power input wiring. Do not use aluminum conductors.
5. For 208-volt power supply, remove orange wire and replace with red wire.
6. Maximum circulator motor is 1/6 hp.

PER Series 3
 15 KW thru 25 KW
 240 VAC/single phase/60 hz
 2½ min. ON, 15 sec. OFF

WEIL-McLAIN
 A United Dominion Company
 Weil-McLain - 500 Blaine St. - Michigan City, IN 46360-2388
 Part Number 550-224-719/0801

WARNING Electrical shock hazard — can cause severe injury or death. Disconnect power before installing or servicing.



Troubleshooting

WARNING

This boiler contains fiberglass materials. Use care when handling these materials per instructions on page 11 of this manual. Failure to comply could result in severe personal injury.

Symptom—No heat

1. Check fuses. Power for the control circuit is supplied through the fuses for the heating element, and the circulator.
2. If fuses are good, jumper the thermostat terminal. If boiler starts, check the thermostat and associated wiring.
3. If thermostat and wiring are good, check the limit control.
 - a. Jumper the “R” and “B” terminals on the “low” side of the control. If the boiler starts, replace the limit control.
 - b. If the boiler does not start in step “a”, momentarily jumper the “R” and “B” terminals on the “high” side of the control. If the boiler starts, replace the limit control.
4. If the limit control is good, check the transformer.
 - a. Measure the A.C. voltage on the transformer. If the A.C. voltage is 24 volts \pm 15%, the transformer is good.
 - b. If the A.C. voltage is low, remove one secondary lead from its load connection.
 - 1) If the A.C. voltage returns to 24V, the transformer is good.
 - 2) If the A.C. voltage remains low, check the primary voltage. It should measure 240 or 480 volts A.C. accordingly \pm 10%. If the primary voltage is correct, replace the transformer.
5. If the transformer is good, follow the voltage path using the wiring diagram. Check each control for voltage in and out. Replace where voltage fails.

Symptom—Low heat

One or more contactors do not energize. Operation of any contactor, beyond the first is dependent upon the operation of three components.

- Thermal time delay.
 - Electronic time delay; 2½ minutes.
 - Contactor.
1. Observe the sequence of operation and note at which contactor it is interrupted. If one contactor fails to energize because of an open coil, subsequent contactors will be affected (unless one has a shorted coil). To isolate the trouble, proceed as follows:
 - a. Check contactor. Connect a jumper from terminal 3 of the electronic delay to the transformer wire going to terminal “B” on the “low” side of the limit control.
 - b. If the contactor energizes check electronic and thermal delays. Remove the jumper from the transformer terminal and touch it to terminal 1 of the electronic delay. (The jumper now connects terminals 1 and 3 of the electronic delay). If the contactor energizes, replace the electronic time delay. If it fails to energize, replace the thermal time delay.

Symptom—Boiler does not shut down

One or more contactors remain on after call for heat ends.

1. Check contactors. Lower the temperature setting on “high” side of the limit control to simulate a limit operation.
 - a. If all contactors instantly de-energize, they are good.
 - b. If one or more contactors fail to de-energize, replace those contactors.
2. If contactors are good, check the thermal delays. Return the temperature setting on the “high” side of the limit control to its original position. Allow the boiler to sequence on with a normal call for heat. When all contactors are energized, lower the setting on the “low” side of the limit control to satisfy the call for heat. Observe the shutdown sequence and note the contactor at which it stops. Remove the wire connecting terminal 1 of the electronic delay to the thermal delay: The contactor will now de-energize, and the remaining contactors will follow in the normal off sequence. Replace the defective thermal delay.

Symptom—Inoperative circulator

1. Measure the voltage at the circulator terminals with the boiler energized. If the voltage is 120V \pm 10%, the control is good. If no voltage is present, replace the circulator relay (1K).



Operating instructions

Water treatment

DANGER

Do not use petroleum-based cleaning or sealing compounds in boiler system. Severe damage to boiler will result, causing substantial property damage.

WARNING

Eliminate all leaks. Continual fresh makeup water will reduce boiler life. Minerals can build up in section, reducing heat transfer, overheating cast iron, and causing section failure.

In hard water areas or low pH conditions (below 7.0), consult local water treatment company. Boiler water pH of 7.0 to 8.5 is recommended.

Freeze protection (when used)

See **WARNING** on page 2 for important information regarding glycol hazard.

WARNING

Do not use automotive, ethylene glycol or undiluted antifreeze. Severe personal injury, death or substantial property damage can result.

Use antifreeze especially made for hydronic systems. Inhibited propylene glycol is recommended.

50% solution provides protection to about -30°F.

Local codes may require a back-flow preventer or actual disconnect from city water supply.

Determine quantity according to system water content. Boiler water content is listed in the Ratings table on page 13. Remember to add in expansion tank water content.

Filling the system with water

CAUTION

Never apply power to the boiler unless the boiler is filled with water.

1. Close manual air vents, drain cocks, and automatic air vent, if used.
2. Fill the boiler and system to an initial pressure of about 12 pounds per square inch.
3. Open automatic air vent one turn, if used.
4. Starting on the lowest floor, open air vents one at a time until water squirts out. Close vent.
5. Repeat with remaining vents.
6. Refill to correct pressure.



Checkout procedure

After filling and purging, start the boiler as follows:

- Turn the thermostat to its lowest setting so that there is no call for heat.
- Set the limit control as recommended in the Installation Instructions.
- Turn on the main electric switch to the boiler.
- Set the thermostat above actual room temperature. Check for proper sequencing of elements. Heat the entire system to about 200°F so that dissolved air and gases in the system water will be emitted and vented.
- Check limit control operation by lowering the control settings as described in the “Troubleshooting” section on page 7.
- Restore the limit control settings to their recommended values and set the thermostat to the desired room temperature.
- Fill in “Installation and service certificate” below.
- If the boiler operates incorrectly or fails to start, refer to “Troubleshooting” on page 7.

Installation and service certificate

Boiler model _____ Series _____ CP number _____ Date installed _____

Measured Btuh input _____

- Installation instructions have been followed.
- Checkout sequence has been performed.
- Above information is certified to be correct.
- Information received and left with owner/maintenance person.

Installer _____
(company)

_____ (address)

_____ (phone)

(installer’s signature)



Maintenance

WARNING

This boiler contains fiberglass materials. Use care when handling these materials per instructions on page 11 of this manual. Failure to comply could result in severe personal injury.

Draining and cleaning

Do not drain the boiler during periods of shutdown unless the heating system is exposed to freezing temperatures. At the end of each heating season, open the boiler drain cock just long enough to remove any impurities or sediment that may have settled to the bottom of the boiler.

Keeping air vent clean

Loosen the cap on the Float-Type Automatic Air Vent two turns while the system is being filled with water. Should dirt or scale lodge on the valve seat causing it to leak, remove the vent cap and push the valve core in by hand to permit water to flush the valve seat clean; release the valve core quickly and replace the vent cap. For normal operation and venting, unscrew the vent cap at least two turns.

Checking relief valve

Check the relief valve once a year by manually opening the valve and allowing a small quantity of water to flow. Make sure that the valve reseats and does not leak. Replace any defective valve.

Checking expansion tank

CAUTION

Undersized expansion tanks cause system water to be lost from relief valve and makeup water added through fill valve. Eventual section failure can result.

If the relief valve opens frequently, check the expansion tank. If the system has a pressurized tank with a rubber diaphragm separating the air cushion from the water (an Ex-Trol or equivalent tank), use a tire pressure gauge to check the air-charging valve on the end of the tank. If water flows, the diaphragm is ruptured or leaking. The tank must be replaced. If no water flows but the air charge has been lost, recharge the tank to 12 pounds per square inch. Periodic air loss from the expansion tank probably means a leaky charging valve.

If the expansion tank is of the standard closed variety, (without a rubber diaphragm) the tank must be partly drained to re-establish an air cushion.

Operating temperature and pressure

The maximum recommended low and high limit control settings are 200°F and 220°F, respectively. The relief valve opens at 30 pounds per square inch. The actual operating pressure will range from 12 pounds per square inch when the system is cold to as much as 15 pounds per square inch at maximum operating temperature.



Handling fiberglass materials

REMOVAL OF FIBERGLASS WOOL — OR —

INSTALLATION OF FIBERGLASS WOOL, COMBUSTION CHAMBER LINING OR BASE PANELS:

WARNING

This product contains fiberglass jacket insulation and ceramic fiber materials in combustion chamber lining or base panels in gas fired products. Airborne fibers from these materials have been listed by the State of California as a possible cause of cancer through inhalation.

- Avoid breathing dust and contact with skin and eyes.
 - Use NIOSH certified dust respirator (N95). This type of respirator is based on the OSHA requirements for fiberglass wool at the time this document was written. Other types of respirators may be needed depending on the job site conditions. Current NIOSH recommendations can be found on the NIOSH web site at <http://www.cdc.gov/niosh/homepage.html>. NIOSH approved respirators, manufacturers, and phone numbers are also listed on this web site.
 - Wear long-sleeved, loose fitting clothing, gloves, and eye protection.
- Operations such as sawing, blowing, tear out, and spraying may generate airborne fiber concentration requiring additional protection.
- Wash potentially contaminated clothes separately from other clothing. Rinse clothes washer thoroughly.

NIOSH stated First Aid.

- Eye: Irrigate immediately
- Breathing: Fresh air.



Dimensions

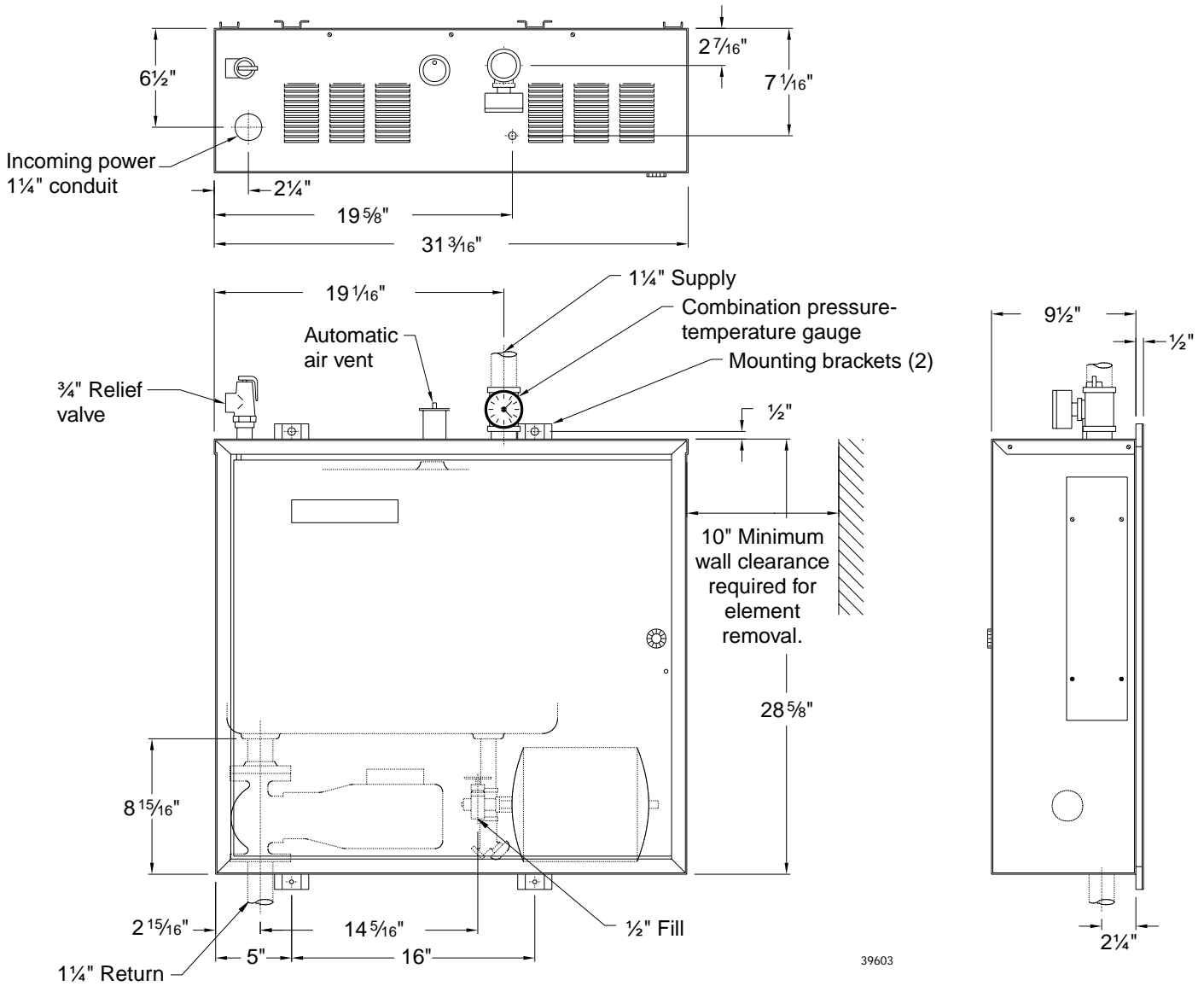



Ratings

DOE



Required wire sizes and weights									
Boiler model number	DOE heating capacity	Boiler input	Number of elements	Element size	Total amperes	Volts phase wire	Wire size 90°C field wiring	Boiler water content	Approximate shipping wt.
	BTU/Hr	KW		KW		(Note 2)	(Note 3)	Gallons	lbs.
PER-15	51,000	15	3	5	65	240/1/3	4	5.2	215
PER-20	68,000	20	4	5	86	240/1/3	3	5.2	215
PER-25	85,000	25	5	5	107	240/1/3	1	5.2	215

Notes:

1. Provide manual shutoff valves in the system piping at the supply outlet and the return inlet so the boiler can be drained without draining the entire system.
2. For other than the standard voltages shown, consult Weil-McLain Application Engineering Department.
3. Copper wire (AWG-MCM). Consult national or local electrical code manuals for runs in excess of 50 feet. Do not use aluminum wire.
4. All ratings are based on 240-volt power input. See Figure 1 for percent of boiler capacity when the input voltage is below 240 volts. Gross output ratings. Piping loss not confined to the heated area should be added to the building loss to determine total heating equipment.

Figure 1 Boiler capacities at various voltages

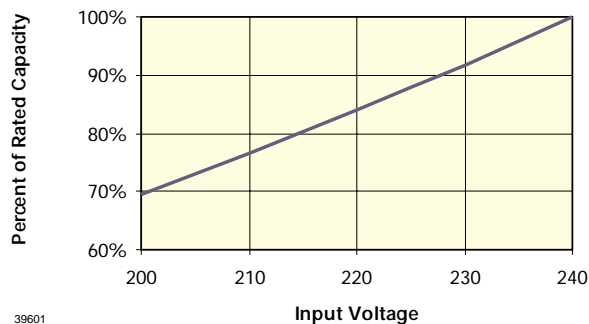

39601



Parts

WARNING

This boiler contains fiberglass materials. Use care when handling these materials per instructions on page 11 of this manual. Failure to comply could result in severe personal injury.

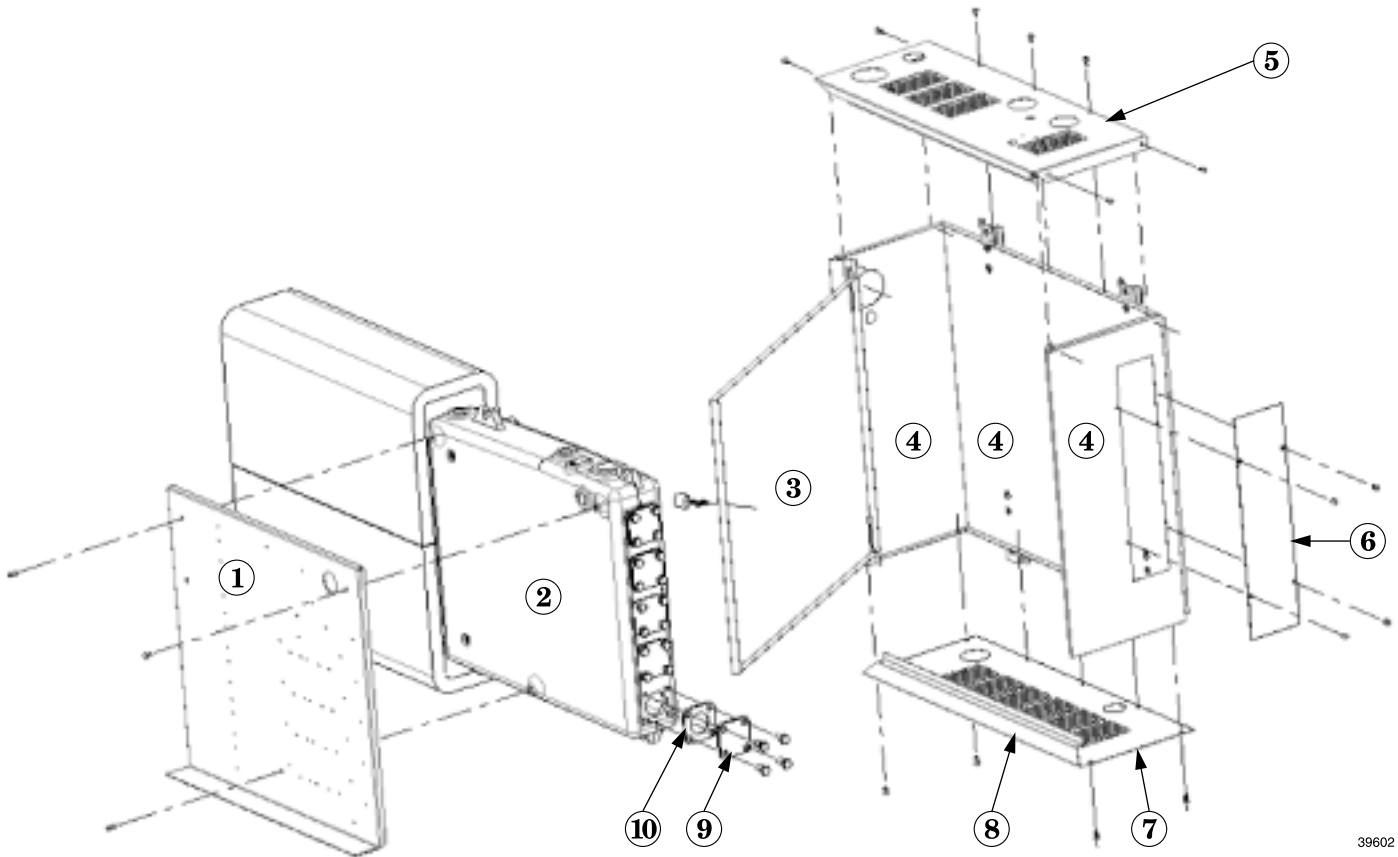

39602

Item number	Description	Weil-McLain part number	Item number	Description	Weil-McLain part number
1	Control tray	428-800-000	6	Jacket element cover plate	428-800-015
2	Boiler casting with insulation	318-806-200	7	Jacket bottom panel	428-600-004
3	Jacket door	428-800-025	8	Jacket bottom cross tie	428-800-010
4	Jacket side and back panel	428-800-020	9	Element opening cover plate	590-243-200
5	Jacket top panel	428-800-005	10	Element opening gasket 1.75 diameter hole 1.50 diameter hole	590-317-523 590-317-524



Parts continued

The following items are available but are not shown in the Parts drawing

Description	Weil-McLain part number
Jacket door latch	562-850-089
Terminal block	512-050-013
Marker strip	590-850-020
Limit control	510-350-061
Circulator relay	510-350-219
Thermostat	511-950-275
Electronic delay, 2½ minutes	510-350-211
Thermal delay, 30 seconds	510-350-220
Retainer clip for thermal delay	562-650-102
Transformer	511-842-361
Line terminal and fuse block (upper)	512-050-002
Line terminal and fuse block (lower)	512-050-004
Fuses, 15A	591-850-172
Fuses, 30A	591-850-174
Relief valve (30 psig)	511-546-924
Temperature pressure gauge	510-218-099
Element contactor, 240 volt, single phase	512-150-147
Heating elements, 5KW, 240V, single phase	591-550-135
Air vent	510-148-567
Fill-Trol, 90° fill	510-632-086
Circulator pump	511-405-117
Universal circulator hardware kit, 1¼"	381-354-526
Drain valve	511-210-423