

**Installation
 Instructions**

**P-35 STEAM
 OIL-FIRED BOILER**

**Weil-McLain
 Company, Inc.**

GENERAL INSTRUCTIONS

Open all boxes and check their contents. In case of shortage or damage notify the transportation company immediately. The side of the boiler to your right as you face the front of the boiler will be referred to in these instructions as the right hand side (R.H.); the side to your left will be referred to as the left hand side (L.H.).

Note: The installation must conform with the requirements of any local, state or insurance requirements or codes having jurisdiction.

AIR SUPPLY FOR BOILER ROOM

Provisions must be made to supply sufficient air to the boiler room at all times for combustion, for ventilation, for operation of the barometric draft control, and to prevent less-than-atmospheric air pressures in the boiler room. If there is a lack of combustion air in the boiler room, the formation of soot can be expected to occur on the boiler flue passages. In buildings of conventional frame, brick, or stone construction without enclosed utility rooms, basement storm windows, or tight stair doors, infiltration is normally adequate to provide air for combustion and for operation of the barometric draft control.

For installations in an enclosed utility room or boiler room without an outside wall, a fresh air opening to the outside with a free cross sectional area of at least twice the area of the flue outlet of the boiler is recommended. For each 1,000 feet above sea level, increase the fresh air opening by 4 per cent. The boiler room should be isolated from any area served by exhaust fans. Do not install an exhaust fan in the boiler room.

IMPORTANT PRECAUTIONS

Proper installation and wiring of the control equipment and proper adjustment of the oil burner is necessary for the successful operation of the oil-fired boiler. Follow the proper wiring diagram furnished inside the envelope which contained these instructions for connecting the electrical supply wiring and for wiring any additional boilers controls.

The P-35 boiler has been factory fire tested; however, the burner must be properly adjusted according to the job conditions to assure efficient operation. Use combustion test instruments to adjust the burner flame as outlined in the burner installation manual.

Adjust the burner to provide a smoke reading of a trace to a No. 1 on the Shell-Bacharach scale with 10.0 per cent to 10.5 per cent CO₂. An over fire draft (negative pressure) of at least -0.02 inches water column is necessary for proper combustion. Refer to the last page of these instructions for the draft loss through the boiler (for the size P-35 boiler being installed) and add the desired -0.02 over fire draft to determine the draft required at

the breeching connection. Be sure the nozzle furnished with the burner is the proper type, spray angle, and rating for the size P-35 boiler being installed.

MINIMUM CLEARANCES

Allow a minimum clearance of at least 24 inches at the front of the boiler for servicing the oil burner controls. For boilers ordered with a tankless heater, allow a minimum clearance of 15 inches at the left side of the boiler for servicing the heater. Provide at least 6 inches clearance at the back, left side, and right side of the boiler.

BOILER FOUNDATION

The P-35 boiler is approved for installation on combustible flooring. The boiler legs provide approximately one inch air space between the bottom of the boiler base and the boiler room floor or boiler foundation for natural aeration.

Where the boiler room floor is not level or where the boiler room floor will not support the weight of the boiler, a boiler foundation will be required. If the boiler foundation is necessary, it should be located to provide proper clearances around the boiler for installation of the supply and return piping, fuel line piping, barometric draft control, breeching, and an indirect water heater (if used). The location of the fuel oil supply tank should also be considered. A level concrete, brick, or wood boiler foundation is suggested and may be any desired height above the boiler room floor if head room permits. The boiler foundation should be constructed according to the chart and Figure 1; these dimensions allow about one inch clearance all around the boiler.

BOILER FOUNDATION SIZES	
Boiler No.	L-Length of Foundation
P-535	18½"
P-635	21½"
P-735	24½"
P-835	27½"

LEVEL FOUNDATION
 AT LEAST TWO INCHES
 ABOVE FLOOR

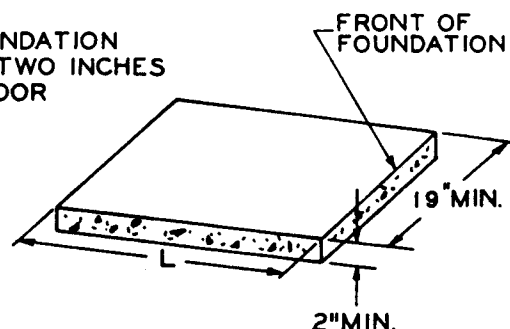

Figure 1

Installation Instructions

P-35 STEAM OIL-FIRED BOILER

Weil-McLain
 Company, Inc.

LOCATING THE BOILER

Remove the wire bound crate and set the boiler on the foundation or on the boiler room floor as directed on the envelope containing these instructions. Position the boiler as close as possible to the chimney and be sure to provide the minimum clearances around the boiler as indicated under Minimum Clearances. When transporting the boiler to the desired position with the wire bound crate removed, do not tip the boiler forward at any time as permanent damage to the burner may result.

HYDROSTATIC PRESSURE TEST OF BOILER

The individual sections and the complete boiler has been hydrostatically pressure tested at the factory; in addition, the boiler has been factory fire tested. The boiler should be pressure tested at the job location to insure that the water-tight seal was maintained during shipment.

1. Remove the shipping nipple from the supply outlet tapping at the top of the boiler and plug any necessary boiler tappings.
2. Connect the water supply to the boiler and fill the boiler with water.
3. Thoroughly inspect the entire boiler for water leaks.
4. Thoroughly drain the entire boiler and remove plugs or fittings.

STEAM BOILER SUGGESTED PIPING CONNECTIONS

Figure 2 and the accompanying chart shows the recommended piping connections and minimum recommended pipe sizes for P-35 steam boilers. The supply and return piping is not furnished with the boiler but should be installed as illustrated. Controls (steam safety valve, low water cut-off, gauge glass, etc.) are not shown on the piping diagram in order to insure clarity of the steam piping.

1. Connect the steam supply riser, header, and equalizer around the boiler as shown in Figure 2. To insure proper performance, the bottom of the supply header must be at least 24 inches above the boiler water line.

a. Connect the system supply piping to the header as shown in Figure 2.

b. Connect the condensate return piping to the equalizer piping 2 inches below the boiler water line.

2. Connect the cold water fill supply piping close to the boiler in the condensate return piping.

3. Connect the steam safety valve outlet to a floor drain or near to the floor. Do not pipe the safety valve discharge to any area where freezing temperatures could occur.

TANKLESS HEATER HOOK-UP

Where a tankless heater was ordered with the P-35 boiler, the heater and temperature operating control will be fac-

RECOMMENDED PIPING CONNECTIONS FOR STEAM BOILERS

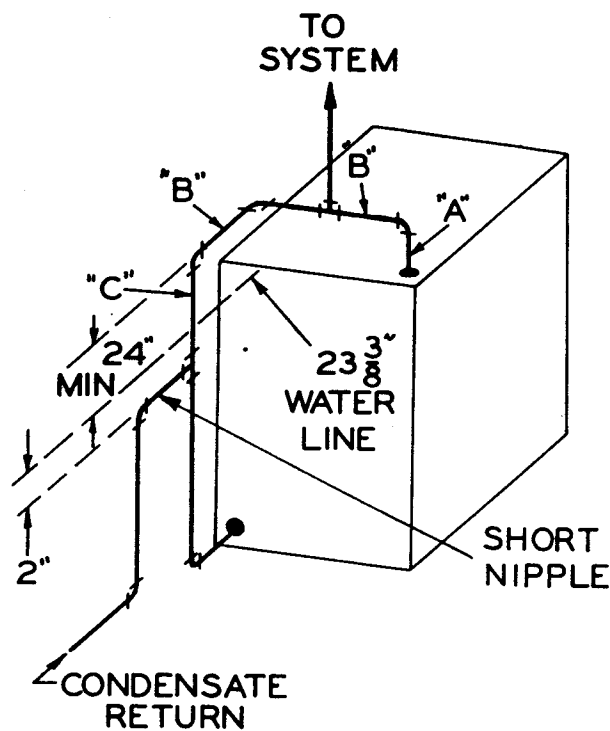

Figure 2

*STEAM BOILER PIPING MINIMUM RECOMMENDED PIPE SIZES

Boiler Number	Supply Pipe Size "A"	Header Pipe Size "B"	Equalizer Pipe Size "C"
P-535-S	2"	2"	1 1/4"
P-635-S	2"	2"	1 1/4"
P-735-S	2"	2"	1 1/4"
P-835-S	2"	2"	1 1/4"

*24" minimum from water line to the bottom of header.

tory installed on the boiler. The tankless heater piping should be installed as illustrated in Figure 3.

1. It is recommended that a Flow Regulating Valve be installed in the cold water supply piping to the tankless heater as illustrated in Figure 3 in order to limit the water flow to the capacity of the heater. The Flow Regulating Valve should be sized according to the intermittent draw rating of the tankless heater in the respective boiler size. Refer to the Tankless Heater Rating Table for tankless heater capacities.

2. An Automatic Mixing Valve should be employed and installed in the domestic hot water supply piping from the heater as illustrated in Figure 3 to permit regulation of the domestic hot water temperature.

**Installation
 Instructions**

**P-35 STEAM
 OIL-FIRED BOILER**

**Weil-McLain
 Company, Inc.**

3. In hard water areas, it would be most advisable to chemically soften the cold domestic supply water to the tankless heater to prevent subsequent lime build-up inside the heater coils. Good results can usually be obtained from a water softener which works on the ion exchange principle.

Ratings-Data-Dimensions. Where the cross sectional area or height of the natural draft chimney or vent is smaller than the published dimensions, or where excessive resistance to the flow of combustion gases can be expected, it may be necessary to purchase and install an inexpensive induced draft fan for best operation. For elevations above 1,000 feet increase the chimney cross sectional area and height at least 4 per cent for each 1,000 feet above sea level.

TANKLESS HEATER PIPING

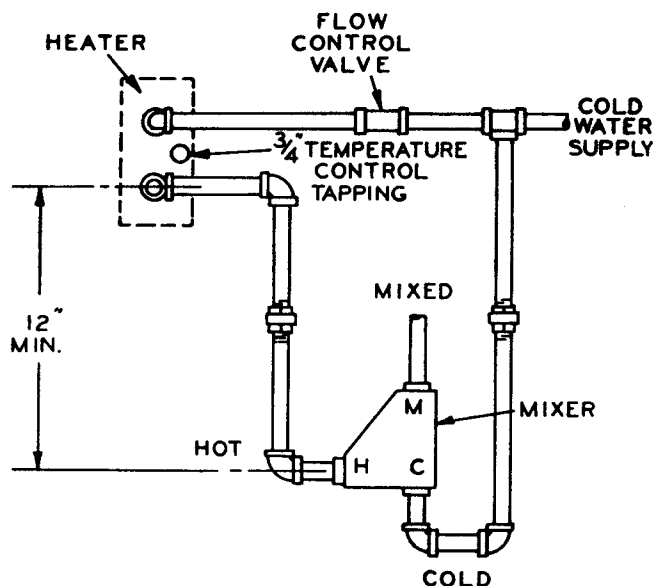

The chimney or vent should extend high enough above the building or any other obstructions so that wind from any direction will not strike the chimney or vent from an angle above horizontal and thus produce down drafts. Unless the obstruction is of great magnitude, it is the usual experience that a chimney or vent extended at least 2 feet above flat roofs or 2 feet above the highest part of wall parapets and peaked roofs which are within 30 feet will be reasonably free from down drafts. The chimney should be examined before the connection of the boiler to be certain that it is properly constructed, clear, and will freely conduct the products of combustion to the atmosphere.

BREACHING ERECTION

In entering the chimney, the breeching connection must be sufficiently above the extreme bottom of the chimney to avoid any danger of stoppage. The breeching connection must not project beyond the inner wall of the chimney. A thimble or slip joint may be used to facilitate removal of the breeching for cleaning. Do not place a damper or any other obstruction in the breeching. The breeching slope upward toward the chimney at least 1/4 inch per lineal foot of breeching and must be at least of the same equivalent diameter as the published dimensions of the rectangular or square chimney. Long horizontal breechings, excessive numbers of elbows or tees, or other obstructions which restrict the flow of combustion gases should be avoided. Install the Barometric Draft Control in the breeching between the boiler and the chimney according to the manufacturer's instructions packaged with the control. Drill a small hole in the breeching just ahead of the boiler smoke collar to facilitate measuring the CO₂ and breeching draft and for taking the smoke reading.

Note: Piping Connections not furnished. Use brass plugs in tees and crosses to facilitate cleaning in hard water areas.

Figure 3

▲ TANKLESS HEATER RATINGS

Boiler Number Steam	Heater Number	*Intermittent Draw GPM 100°F. Average Temp. Rise	**Continuous Draw GPM 100°F. Temp. Rise	Inlet and Outlet Tappings	Temp. Control Tapping
P-535-S	35-S-29	3.25	2.60	3/4"	3/4"
P-635-S	35-S-29	3.50	3.20	3/4"	3/4"
P-735-S	35-S-29	3.75	3.80	3/4"	3/4"
P-835-S	35-S-29	4.00	4.40	3/4"	3/4"

BURNER AND SAFETY CIRCUIT WIRING

The burner motor, ignition transformer, low water cut-off, burner primary control, and limit control are prewired at the factory. If any additional electrical safety controls are employed, No. 14 gauge wire may be used. The power input supply wiring to the burner should be No. 14 gauge wire or heavier, as required, and should have a properly sized fused disconnect switch.

▲ Weil-McLain ratings based on 60 P.S.I.G. domestic water pressure at heater.
 *Gallons of water heated per minute from 40°F. to 140°F. with 200°F. boiler water temperature.
 **Continuous draw, no recovery period.

CHIMNEY OR VENT

The P-35 boilers are designed only for natural draft firing. The natural draft chimney or vent must be at least of the size indicated on the last page of these instructions under

BURNER ADJUSTMENT

Refer to the burner installation and service manual for starting the burner. Be sure the fuel oil tank and fuel line piping are sized correctly and installed as directed. Start

**Installation
 Instructions**

**P-35 STEAM
 OIL-FIRED BOILER**

**Weil-McLain
 Company, Inc.**

the burner and adjust the air band so that a clean yellow flame is established avoiding smoky tips.

After the boiler starts steaming, use combustion test instruments for final adjustment of the burner flame. A smoke reading of a trace to No. 1 on the Shell Bacharach scale is recommended with 10.0 per cent to 10.5 per cent CO₂. Adjust the barometric draft control to provide -0.02 negative over-fire draft.

CLEAN THE NEW STEAM BOILER

New steam boilers must be cleaned properly previous to or during the first few days of operation. Follow the cleaning recommendations listed on the Operating Instructions enclosed in the envelope with these instructions. Do not

use chemical cleaners in this boiler!

BOILER SERVICE AND MAINTENANCE

Before leaving the job make sure the high limit control is operating properly by moving the indicator below the actual boiler water temperature while the thermostat control is calling for heat; the burner should then stop. Move the indicator to the normal setting and the burner should again start. Test the action of the additional electrical safety controls using the preceeding procedures.

The boiler Operating Instructions contain information for the owner. Review this information with the owner and/or the owner's representative and be sure he receives all instructions.



Net ratings approved by Institute of Boiler and Radiator Mfrs.

RATINGS ... DATA

All Boiler and Auxiliary Equipment subject to change without notice.



Built to ASME specifications

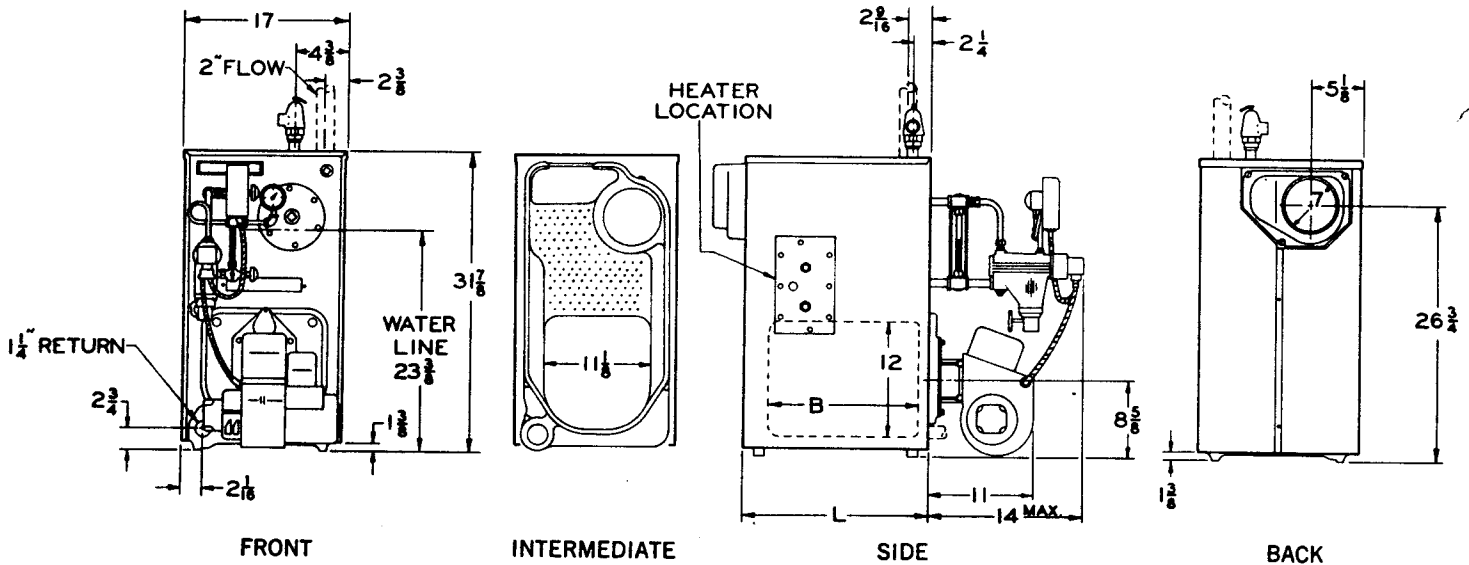

Boiler Number	Net I-B-R Ratings				Draft Loss Through Boiler Inches Water Column	Supply Outlet Pipe Size	Return Inlet Pipe Size	Dimensions in Inches		I-B-R Chimney Size	
	I-B-R Burner Capacity G.P.H.	Gross I-B-R Output BTU/Hr.	Net I-B-R Output BTU/Hr.	Net Sq. Ft. Steam				B	L	Size Inches	Height Feet
P-535-S*	1.20	130,000	97,000	405	0.034	2"	1 1/4"	12-7/8	16-3/8	8 x 8	15
P-635-S*	1.50	160,000	120,000	500	0.033	2"	1 1/4"	15-7/8	19-3/8	8 x 8	15
P-735-S*	1.75	190,000	142,500	595	0.032	2"	1 1/4"	18-7/8	22-3/8	8 x 8	15
P-835-S*	2.05	220,000	165,000	690	0.031	2"	1 1/4"	21-7/8	25-3/8	8 x 8	15

*Add suffix "T" for steam boiler ordered with tankless heater (see tankless heater capacity chart, tankless heater cannot be used with P-435-S boiler).

†Net I-B-R Steam Ratings are based on net installed radiation of sufficient quantity for the requirements of the building and nothing need be added for normal piping losses and pick-up loads. Ratings are computed on an allowance factor of 1.333. An additional allowance should be made for usual piping losses and/or pick-up loads.

WEIL-McLAIN COMPANY INC. MICHIGAN CITY, INDIANA

