



# CGi Gas-fired boiler Induced draft

- Installation • Start-Up • Service
- Troubleshooting • Repair Parts



## Read all instructions before installing

**Installer** Leave this manual in the envelope and affix near the boiler.  
Consider venting and piping locations when determining boiler location.  
Any claims for damage or shortage in shipment must be filed immediately against the transportation company by the consignee.

**User** Boiler Manual is only to be used and boiler installed by a qualified installer/service technician.  
User's Information Manual is for your reference.  
Regular service by your qualified service technician is recommended.

# Read This Page First



## Hazard Definitions

The following terms are used to bring attention to the presence of hazards of various risk levels or to important information concerning product life.

- DANGER** Indicates presence of hazards that will cause severe personal injury, death or substantial property damage if ignored.
  
- WARNING** Indicates presence of hazards that can cause severe personal injury, death or substantial property damage if ignored.
  
- CAUTION** Indicates presence of hazards that will or can cause minor personal injury or property damage if ignored.
  
- NOTICE** Indicates special instructions on installation, operation or maintenance that are important but not related to personal injury hazards.

## When Calling or Writing About the Boiler

Please have boiler model number from boiler rating label and CP number from boiler jacket. You may list the CP number in the space provided on page 33.

- WARNING** Read all instructions before installing boiler. Failure to follow instructions in proper order can cause severe personal injury, death or substantial property damage.

# Table of Contents



Read This Page First .....	2
Table of Contents .....	3
Before Installing Boiler .....	4
Boiler Preparation .....	7
Water Piping .....	8
Venting and Combustion Air .....	18
Chimney Draft Venting .....	19
Direct Exhaust Vent Location .....	20
Direct Exhaust with AL29-4C .....	21
Gas Piping .....	29
Wiring .....	30
Start-Up .....	30
Check-Out Procedure .....	33
Installation and Service Certificate .....	33
Suggested Minimum Service .....	34
Control System .....	36
Wiring Diagram .....	37
Sequence of Operation .....	38
Operating Instructions .....	39
Troubleshooting .....	42
Parts List .....	48
Ratings .....	54
Dimensions .....	55

# Before Installing Boiler



## Special note on combustion air supply:

All boilers experience some condensation in section assembly during start-up. Flue gas condensate is slightly acidic. In most cases pH level is not harmful to vents or drains. When combustion air is contaminated by vapors from products or areas listed below, condensate acidic levels increase. Higher acidic levels attack many materials, including stainless steels.

You may need to isolate the boiler if installation is in an area containing contaminants listed below, which will induce acidic contamination.

Products causing contaminated air:

1. spray cans containing chloro/fluorocarbons
2. permanent wave solutions
3. chlorinated waxes/cleaners
4. chlorine-based swimming pool chemicals
5. calcium chloride used for thawing
6. sodium chloride used for water softening
7. refrigerant leaks
8. paint or varnish removers
9. hydrochloric acid/muriatic acid
10. cements and glues
11. antistatic fabric softeners used in clothes dryers
12. chloride-type bleaches, detergents, and cleaning solvents found in household laundry rooms
13. adhesives used to fasten building products
14. . . . and other similar products

Areas causing contaminated combustion air:

1. dry cleaning/laundry areas and shops
2. metal fabrication plants
3. beauty shops
4. refrigeration repair shops
5. photo processing plants
6. auto body shops
7. plastic manufacturing plants
8. furniture refinishing areas and shops
9. new building construction
10. remodeling areas
11. . . . and other similar areas

**WARNING** To prevent potential of severe personal injury or death, check for products or areas listed above before installing boiler. If found:

- remove products permanently.  
OR
- isolate boiler and provide outside combustion air. See national, provincial or local codes for further information.

## Installations must comply with latest editions:

- U.S.
  - National, state and local codes, laws, regulations and ordinances.
  - National Fuel Gas Code, ANSI Z223.1.
  - Standard for Controls and Safety Devices for Automatically Fired Boilers, ANSI/ASME CSD-1, when required.
  - National Electrical Code.
- Canada
  - National, provincial and local codes, laws, regulations and ordinances.
  - CAN/CGA B149.1 or B149.2 Installation Code.
  - C.S.A. C22.1 Canadian Electrical Code Part 1.

Gas manifold and controls met safe lighting and other performance criteria when boiler underwent tests specified in ANSI Z21.13 - latest edition.

## Before locating boiler:

- Check for nearby connections to:
  - System water piping.
  - Venting connections.
  - Gas supply piping.
  - Electrical power.
- Check area around boiler. Remove any combustible materials, gasoline and other flammable liquids.

**WARNING** Failure to keep boiler area clear and free of combustible materials, gasoline and other flammable liquids and vapors can result in severe personal injury, death or substantial property damage.

- Boiler must be installed so that gas control system components are protected from dripping or spraying water or rain during operation or service.
- If new boiler will replace existing boiler, check for and correct system problems, such as:
  1. System leaks, causing oxygen corrosion or section cracks from hard water deposits.
  2. Incorrectly sized expansion tank.
  3. Lack of antifreeze in boiler water, causing system and boiler to freeze and leak.

# Before Installing Boiler

**Provide clearances:**

- Hot water pipes - at least 1/2 inch from combustible materials.
- Recommended service clearances - Figure 1.
- Minimum clearances for tight spaces - Figure 2.

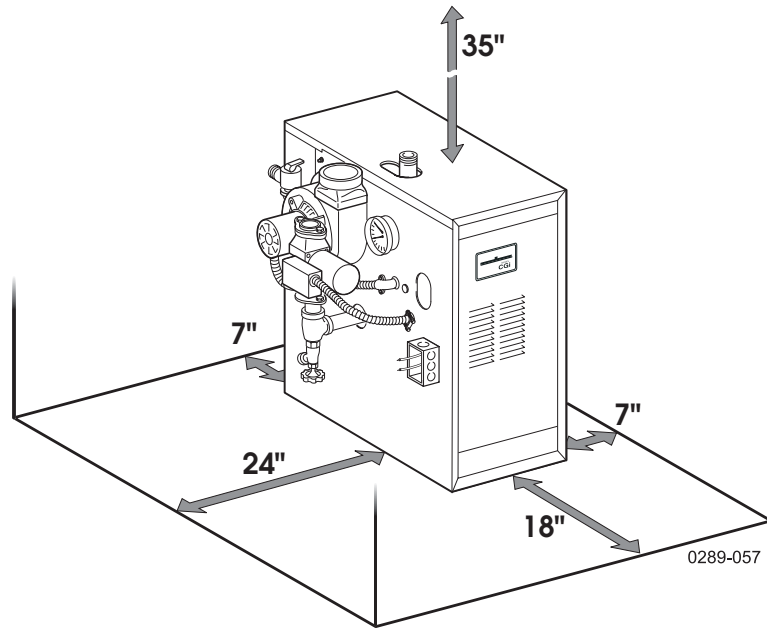

**Recommended service clearances  
 FIGURE 1**

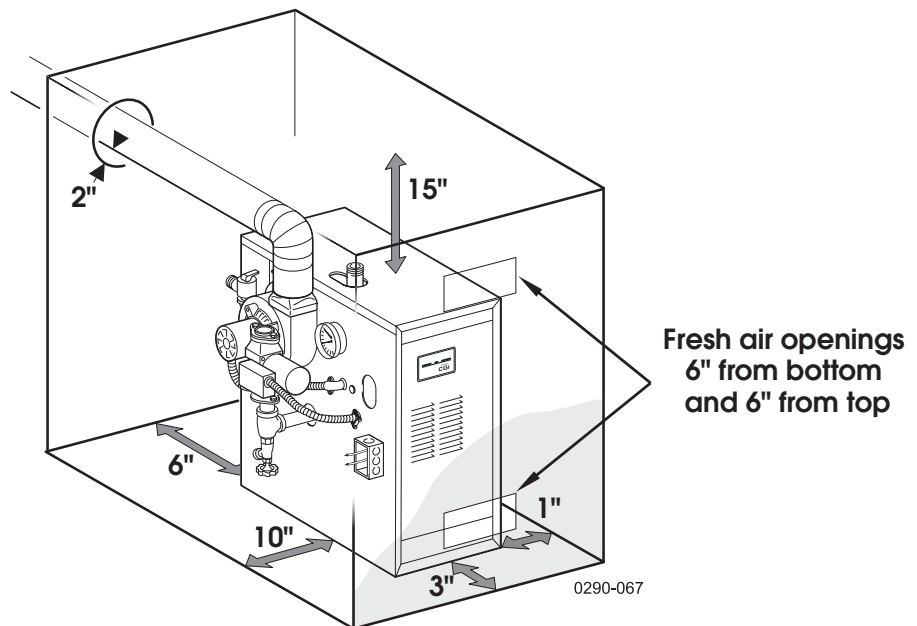

**Minimum clearances for tight spaces  
 FIGURE 2**

# Before Installing Boiler

## When removing existing boiler from common venting system:

**WARNING** Failure to follow all instructions listed below can result in flue gas spillage and carbon monoxide emissions, causing severe personal injury or death.

At the time of removal of an existing boiler, the following steps shall be followed with each appliance remaining connected to the common venting system placed in operation, while the other appliances remaining connected to the common venting system are not in operation.

1. Seal any unused openings in the common venting system.
2. Visually inspect the venting system for proper size and horizontal pitch and determine there is no blockage or restriction, leakage, corrosion and other deficiencies which could cause an unsafe condition.
3. Insofar as is practical, close all building doors and windows and all doors between the space in which the appliances remaining connected to the common venting system are located and any other spaces of the building. Turn on clothes dryers and any appliance not connected to the common venting system. Turn on any exhaust fans, such as range hoods and bathroom exhausts, so they will operate at maximum speed. Do not operate a summer exhaust fan. Close fireplace dampers.
4. Place in operation the appliance being inspected. Follow the operating instructions. Adjust thermostat so appliance will operate continuously.
5. Test for spillage at draft hood relief opening after 5 minutes of main burner operation. Use the flame of a match or candle, or smoke from a cigarette, cigar or pipe.
6. After it has been determined that each appliance remaining connected to the common venting system properly vents when tested as outlined above, return doors, windows, exhaust fans, fireplace dampers, and any other gas-burning appliance to their previous conditions of use.

Any improper operation of the common venting system should be corrected so the installation conforms with the National Fuel Gas Code, ANSI Z223.1-latest edition. Correct by resizing to approach the minimum size as determined using the appropriate tables in Part 11 of that code. Canadian installations must comply with CAN/CGA B149.1 or B149.2 Installation Code.

## Lay a foundation, if needed:

CGi boiler is approved for use on combustible flooring; however, boiler must not be installed on carpeting.

**WARNING** Do not install boiler on carpeting even if a foundation is used. Fire can result, causing severe personal injury, death or substantial property damage.

1. For residential garage installation, install boiler so burners are at least 18 inches above floor to avoid contact with gasoline fumes.
2. A level concrete or masonry foundation is required when:
  - Water could flood area.
  - Non-level conditions exist.

TABLE 1 - Boiler foundation size			
Boiler Model	Length Inches	Width Inches	Min. Height Inches
CGi - 25	25	12	2
CGi - 3	25	12	2
CGi - 4	25	15	2
CGi - 5	25	18	2
CGi - 6	25	21	2
CGi - 7	25	24	2

# Boiler Preparation



## Place the boiler:

1. Leave boiler in crate and on pallet until installation site is ready.
2. Move entire crate and pallet next to selected location.
3. Remove crate.
4. Remove boiler from pallet:
  - a. Tilt left side of boiler up and place a board under left legs.
  - b. Tilt boiler the other way and place a board under right legs.
  - c. Slide boiler backward off pallet and into position.

**NOTICE** Do not drop boiler or bump jacket on floor or pallet. Damage to boiler can result.

5. Check level. Shim legs, if needed. Do not alter legs.
6. Remove front jacket door. Remove base access panel.
7. Check for correctly-sized manifold orifices from Table 2. The orifice size is stamped on the orifice spud barrel.

**DANGER** Correctly-sized manifold orifices must be used. Failure to do so will result in severe personal injury, death or substantial property damage.

TABLE 2 - Manifold orifice size			
Natural Gas		Propane	
U.S.			
2.0 MM *		1.3 MM *	
Canada			
0 TO 2000 FT.	2000- 4500 FT.	0 TO 2000 FT.	2000- 4500 FT.
2.0 MM	#49	1.3 MM	#56

\* For elevations above 2000 feet, contact your local Weil-McLain sales office for details.

8. Level and straighten burners.

**DANGER** Burners must be properly seated in burner rest slots with their openings face up. Main burner orifices must inject down center of burner. Failure to properly seat burners will result in severe personal injury, death or substantial property damage.

9. Reinstall burner access panel.

**DANGER** Burner access panel must be in position during boiler operation to prevent momentary flame rollout on main flame ignition. Failure to do so will result in severe personal injury, death or substantial property damage.

## Perform hydrostatic pressure test:

1. Pressure test boiler before attaching piping or electrical supply.
2. Remove shipping nipple from supply outlet. Remove relief valve.
3. Install air vent in tapping on top of boiler.
4. Plug remaining tappings, including relief valve opening.
5. Connect water supply. Fill boiler and purge all air. Test at 1-1/2 times working pressure.

**WARNING** Do not leave boiler unattended. A cold water fill could expand and cause excessive pressure, resulting in severe personal injury, death or substantial property damage.

6. Check for maintained gauge pressure for more than 10 minutes. Visually check for leaks if gauge pressure drops.
7. Drain boiler and repair leaks if found.

**DANGER** Do not use petroleum-based compounds to repair leaks. Severe damage to boiler will occur, resulting in severe personal injury, death or substantial property damage.

8. Retest boiler after repairing leaks.
9. Remove testing plugs and air vent.

# Water Piping



## General piping information:

- If installation is to comply with ASME or Canadian requirements, an additional high temperature limit is needed. Install control in supply piping between boiler and isolation valve. Set second control to minimum 20°F above set point of first control. Maximum allowable set point is 240°F. See page 37 for wiring.
- Use a low water cutoff device when:
  - Boiler is installed above radiation level.
  - Required by certain state or local codes or insurance companies.
 Use low water cutoff designed for water installations. Probe type is recommended. Purchase and install in tee in supply line above boiler.
- Use backflow check valve in cold water supply as required by local codes.
- Install boiler so that chilled medium is piped in parallel with heating boiler. Use appropriate valves to prevent chilled medium from entering boiler. Consult I=B=R Installation and Piping Guides.
- If boiler is connected to heating coils located in air handling units where they can be exposed to refrigerated air, use flow control valves or other automatic means to prevent gravity circulation during cooling cycle.

## Install piping:

1. See Figure 3A or 3B and Table 3 for near-boiler piping and single-zone piping. See page 10 for boilers used with refrigeration systems. See page 11 to complete multiple-zone piping or pages 12 – 17 to complete piping for radiant panel systems or converted gravity systems.
2. Install relief valve vertically in tapping on side of boiler. See Figure 3A or 3B and the tag attached to the relief valve for manufacturer's instructions.

**WARNING** Pipe relief valve discharge line near floor close to floor drain to eliminate potential of severe burns. Do not pipe to any area where freezing could occur. Do not plug, valve, or place any obstruction in discharge line.

## DIAPHRAGM expansion tank (Figure 3A):

1. Ensure expansion tank size will handle boiler and system water volume and temperature. Tank must be located in boiler return piping as close to boiler as possible, before inlet side of circulator. See tank manufacturer's instructions for details.

**CAUTION** Undersized expansion tanks cause system water to be lost from relief valve and makeup water to be added through fill valve. Eventual section failure can result.

2. Install automatic air vent as shown.

## CLOSED expansion tank (Figure 3B):

1. Ensure expansion tank size will handle boiler and system water volume and temperature. See tank manufacturer's instructions for details.

**CAUTION** Undersized expansion tanks cause system water to be lost from relief valve and makeup water to be added through fill valve. Eventual section failure can result.

2. Connect tank to 1/2" N.P.T. tapping located behind supply outlet, using 1/2" N.P.T. piping. Pitch any horizontal piping up towards tank 1 inch per 5 feet of piping.

BOILER MODEL	TO SYSTEM	FROM SYSTEM
CGi - 25	3/4"	3/4"
CGi - 3	1"	1"
CGi - 4	1"	1"
CGi - 5	1"	1"
CGi - 6	1 1/4"	1 1/4"
CGi - 7	1 1/4"	1 1/4"

\* All piping sizes based on 20°F temperature rise through boiler.

## Near boiler piping

For low return temperature systems, see additional requirements shown on pages 10 through 17

Piping with DIAPHRAGM expansion tank

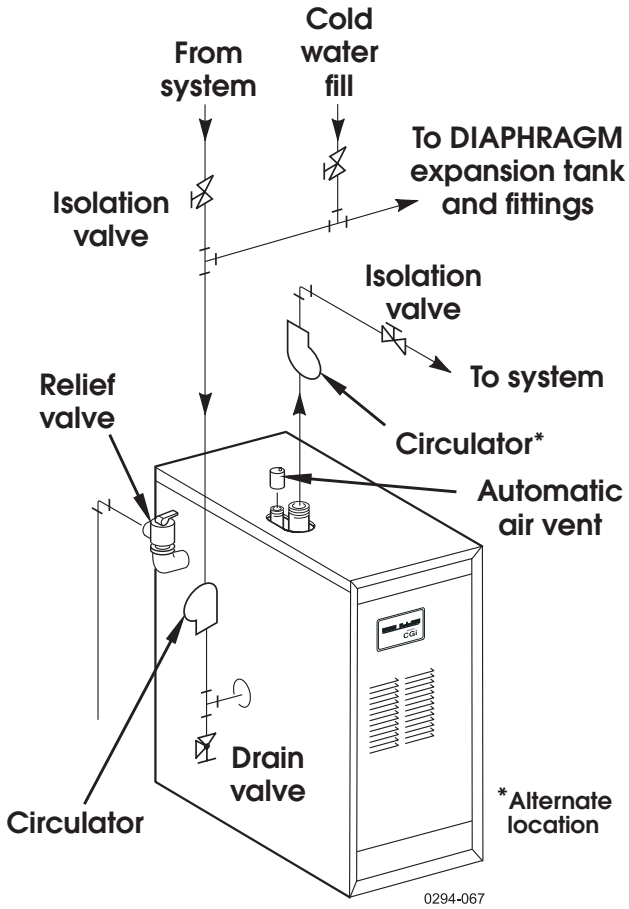

FIGURE 3A

Piping with CLOSED expansion tank

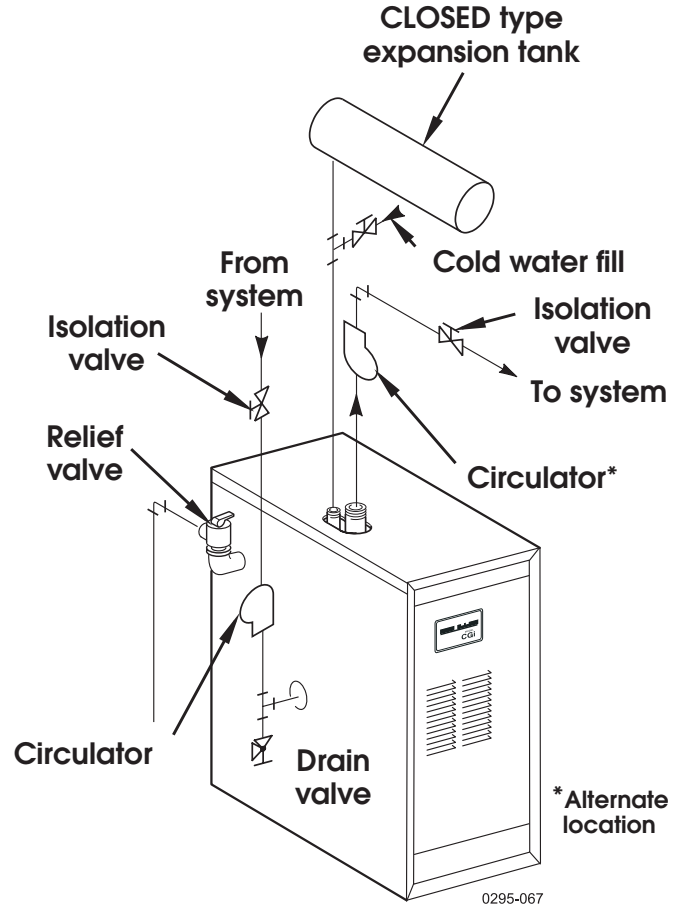

FIGURE 3B

**WARNING** For systems with low return water temperature possible (such as converted gravity systems and radiant heating systems), refer to the special piping suggestions of pages 12 – 17. Failure to prevent low return water temperature to the boiler could cause corrosion of the boiler sections or burners, resulting in severe personal injury, death or substantial property damage.

## Piping MULTIPLE ZONES:

1. Follow instructions on pages 8 and 9 to install near-boiler piping. (Also refer to **Piping for radiant heating systems or converted gravity systems** if applicable.)
2. See Figure 5A or 5B to complete installation.
3. Zoning with **circulators**:
  - a. Size each circulator to individual circuit requirements.
  - b. Remove circulator on boiler.
4. Zoning with **zone valves**:
  - a. Install balancing valves to adjust flow to distribute heat to all zones.
  - b. Separate transformer is required to power zone valves.
- c. Install balancing valves to adjust flow to distribute heat to all zones.
- d. Separate relay is required for each circulator.

## Piping for RADIANT HEATING SYSTEMS or CONVERTED GRAVITY SYSTEMS

### Converted gravity (or steam) systems

Whenever possible, use the primary/secondary piping shown in Figure 6A or 6B. This piping design allows changing boiler flow rate without affecting primary circuit flow rate.

If Figure 6A or 6B cannot be used, use the boiler by-pass piping shown in Figure 7A or 7B.

You can also use the piping shown in Figure 8 (system by-pass) if the reduced flow rate in the heating system will not cause heat distribution problems.

**WARNING** Failure to prevent low return water temperature to the boiler could cause corrosion of the boiler sections or burners, resulting in severe personal injury, death or substantial property damage.

### Radiant heating systems

Preferably, use primary/secondary piping, as shown in either Figure 6A or 6B. Alternatively, use the method of either Figure 7A or 7B. Do not use the piping of Figure 8, because this method does not control radiant system supply temperature.

If radiant system tubing has no oxygen barrier, a heat exchanger must be used.

**WARNING** Radiant heating system piping should include a means of regulating the boiler return water temperature **AND** the system supply temperature (such as provided by an injection pumping control). Boiler return water temperature will be adequately controlled using the methods shown in this manual provided the system supply temperature is relatively constant.

- DO NOT apply the methods in this manual if the system is equipped with an outdoor reset control. Instead, provide controls and piping which can regulate the boiler return water temperature at no less than 130 °F regardless of system supply temperature. Contact your Weil-McLain representative for suggested piping and control methods. Failure to prevent cold return water temperature to the boiler could cause corrosion damage to the sections or burners, resulting in possible severe personal injury, death or substantial property damage.

## Piping for use with REFRIGERATION SYSTEMS:

The boiler must be installed so the chilled medium is piped in parallel with the heating boiler, using appropriate valves to prevent the chilled medium from entering boiler. Use piping as shown in Figure 4.

If the boiler is connected to heating coils located in air handling units where they can be exposed to refrigerated air, gravity circulation during the cooling cycle must be prevented with flow control valves or other automatic means.

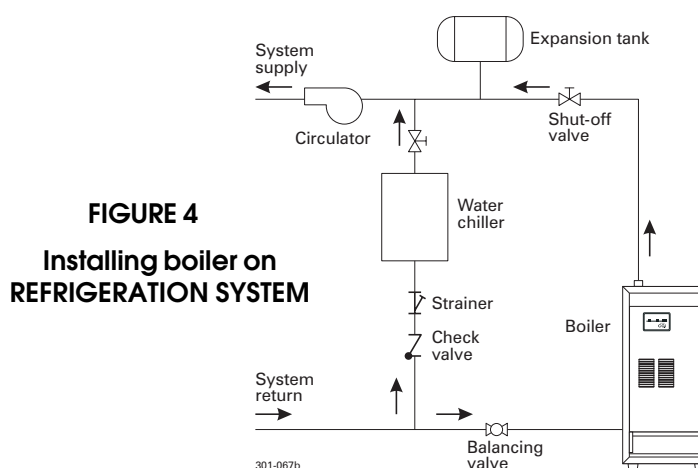
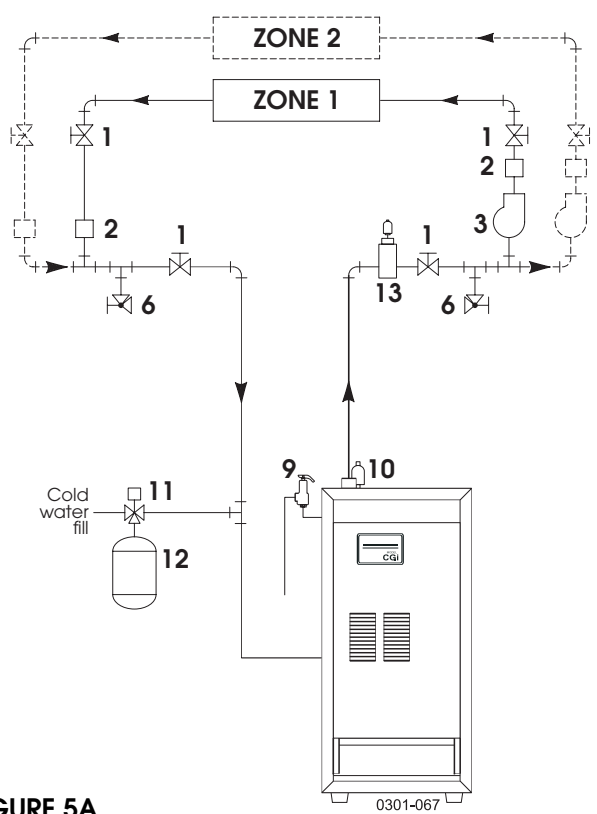

**FIGURE 4**  
**Installing boiler on**  
**REFRIGERATION SYSTEM**

## Typical piping for MULTIPLE ZONE installations

Applicable for systems with boiler return water temperature at least 130 °F  
 (Refer to pages 12 through 17 for low temperature systems)

**Zoning with circulators**



**FIGURE 5A**

**Zoning with zone valves**

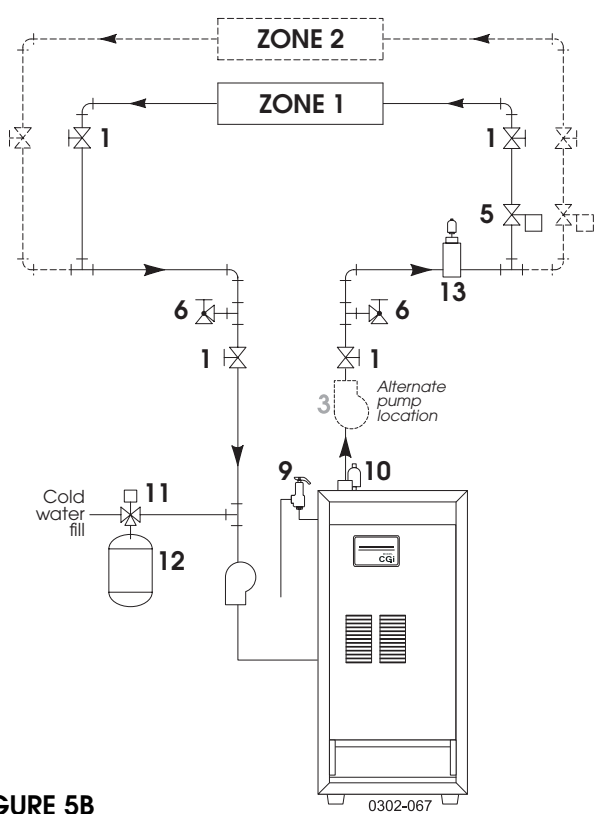

**FIGURE 5B**

**Legend** (For Figures 5A and 5B) .....

- |  |   |
|--|---|
| <ul style="list-style-type: none"> <li>1 Isolation valve</li> <li>2 Flow/check valve</li> <li>3 Circulator</li> <li>5 Zone valve</li> <li>6 Drain valve</li> <li>9 Relief valve</li> <li>10 Automatic air vent</li> <li>11 Fill valve</li> </ul> | <ul style="list-style-type: none"> <li>12 Diaphragm expansion tank<br/>(see Figure 3B if using closed type expansion tank. DO NOT use automatic air vent with closed type expansion tank.)</li> <li>13 In-line air separator and automatic vent, if used<br/>(Note that the fill valve must always be connected to the expansion tank, regardless of location of expansion tank, circulator or air separator.)</li> </ul> |
|--|---|

**WARNING** For systems with low return water temperature possible (such as converted gravity systems and radiant heating systems), refer to the special piping suggestions of pages 12 – 17. Failure to prevent low return water temperature to the boiler could cause corrosion of the boiler sections or burners, resulting in severe personal injury, death or substantial property damage.

# Water Piping - Low Temp Systems



## Piping for RADIANT HEATING SYSTEMS or CONVERTED GRAVITY SYSTEMS — By-pass arrangements using PRIMARY/SECONDARY piping (preferred)

Figures 6A and 6B show suggested piping arrangements for low temperature systems using primary/secondary piping. (For alternatives, see pages 14 through 17.)

Primary/secondary piping is preferred because the flow rate and temperature drop in the heating circuit(s) is determined only by the heating circuit pumps(s). So adjustment of the by-pass valves in the boiler circuit will not cause a change in the heating circuit flow rate and temperature distribution.

The by-pass valves (items 7a and 7b) provide mixing of hot boiler outlet water with cooler system return water — set to assure a minimum return water temperature (at least 130 °F) to the boiler. Set the valves as explained in the following section.

### Temperature gauges

Gauge 4a is suggested, but optional on any system.

Gauge 4b is optional on converted gravity systems, but **required** on radiant heating systems — to display the water temperature being supplied to the radiant tubing.

Gauge 8 is **required** on all systems to assure the return water temperature is accurately set for a minimum of 130 °F. If this gauge is not available, however, adjust the valves such that the boiler-mounted pressure/temperature gauge reads at least 150 °F when the system return water is cold (approximately 60 °F water temperature).

**WARNING** Failure to prevent low return water temperature to the boiler could cause corrosion of the boiler sections or burners, resulting in severe personal injury, death or substantial property damage.

**WARNING** Radiant heating system piping should include a means of regulating the boiler return water temperature **AND** the system supply temperature (such as provided by an injection pumping control).

- Boiler return water temperature will be adequately controlled using the methods shown in this manual provided the system supply temperature is relatively constant.
- DO NOT apply the methods in this manual if the system is equipped with an outdoor reset control. Instead, provide controls and piping which can regulate the boiler return water temperature at no less than 130 °F regardless of system supply temperature. Contact your Weil-McLain representative for suggested piping and control methods.
- Failure to prevent cold return water temperature to the boiler could cause corrosion damage to the sections or burners, resulting in possible severe personal injury, death or substantial property damage.

### Adjust valves as follows (Fig. 6A & 6B only):

1. Set the valves while the system is cool, setting for the coldest expected water temperature (usually 60 °F since the system will often drop to room temperature between cycles).
2. Start with valve 7a fully closed and 7b fully open.
3. Gradually open valve 7a while closing valve 7b until the temperature at gauge 8 reads 130 °F when gauge 4a reads 60 °F.
4. Note that valve 7a regulates the amount of hot water from the boiler supply which mixes with return water. Valve 7b regulates the amount of system water flowing through the boiler secondary loop.



## By-pass arrangements using PRIMARY/SECONDARY piping (PREFERRED) for RADIANT HEATING SYSTEMS or CONVERTED GRAVITY SYSTEMS

(Do not apply to systems using outdoor reset controls)

**Zoning with circulators**

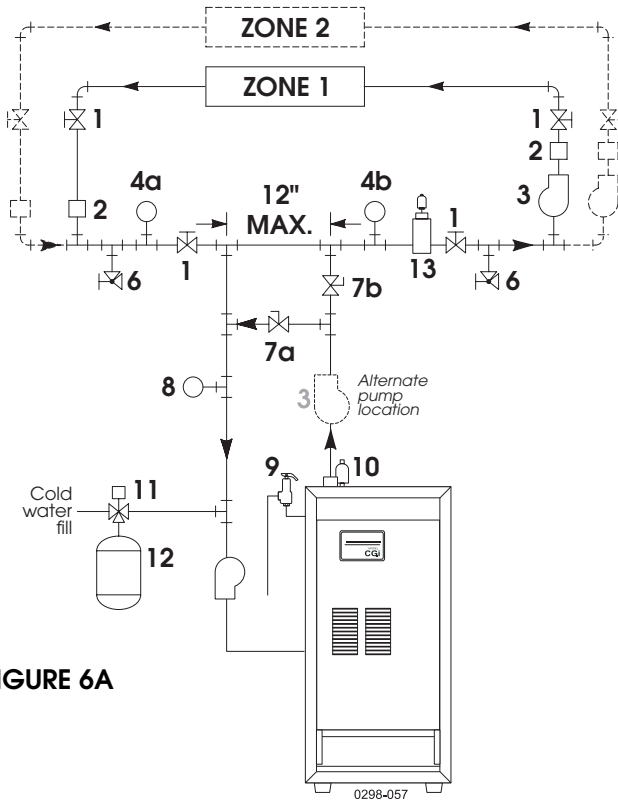

**FIGURE 6A**

**Zoning with zone valves**

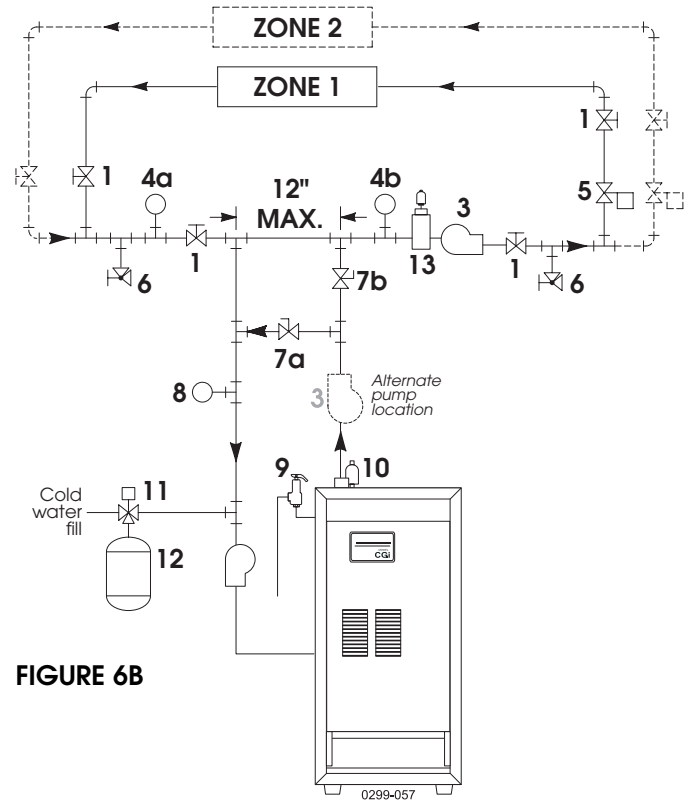

**FIGURE 6B**

**Legend** (For Figures 6A and 6B) .....

- |  |   |
|--|---|
| <ul style="list-style-type: none"> <li><b>1</b> Isolation valve</li> <li><b>2</b> Flow/check valve</li> <li><b>3</b> Circulator</li> <li><b>4</b> System temperature gauges</li> <li><b>5</b> Zone valve</li> <li><b>6</b> Drain valve</li> <li><b>7</b> System temperature valves<br/>(see instructions at left for adjusting valves)</li> <li><b>8</b> Blend temperature gauge</li> <li><b>9</b> Relief valve</li> <li><b>10</b> Automatic air vent</li> </ul> | <ul style="list-style-type: none"> <li><b>11</b> Fill valve</li> <li><b>12</b> Diaphragm expansion tank<br/>(see Figure 3B if using closed type expansion tank. DO NOT use automatic air vent with closed type expansion tank.)</li> <li><b>13</b> In-line air separator and automatic vent, if used<br/>(Note that the fill valve must always be connected to the expansion tank, regardless of location of expansion tank, circulator or air separator.)</li> </ul> |
|--|---|



## Piping for RADIANT HEATING SYSTEMS or CONVERTED GRAVITY SYSTEMS — Alternate by-pass piping arrangements

Figures 7A and 7B are alternative piping suggestions for large water content (converted gravity or steam systems) or radiant heating systems — for use when primary/secondary piping can't be applied. (Figure 8 is another alternative, using system by-pass in place of boiler by-pass piping. Figure 8, however, is not suitable for radiant heating applications because it does not protect the radiant system from possible high water temperature.)

This piping method is called a "boiler by-pass" because part of the pump flow is by-passed around the boiler (through valve 7a). This method reduces the flow rate through the boiler, in order to raise the average water temperature in the boiler enough to prevent flue gas condensation. Boiler by-pass piping is effective for some boilers — including the CGi — provided the flow rates are adjusted according to the instructions following.

Boiler by-pass piping keeps system flow rate as high as possible and temperature drop as low as possible, helping to equalize the building heat distribution.

### Temperature gauges

Gauge 4a is optional if the by-pass valves will be adjusted using cold (or room temperature) return water to the boiler. (When setting the valves without gauge 4a installed — using cold or room temperature water — assume the return water temperature to be 60 °F. Set the valves so gauge 8 reads at least 120 °F.)

Gauge 4b is optional on converted gravity systems, but **required** on radiant heating systems — to display the water temperature being supplied to the radiant tubing.

Gauge 8 is **required** on all systems to assure reliable adjustment of the by-pass valves. The boiler-mounted pressure/temperature gauge can be used if a separate temperature gauge is not installed.

**WARNING** Failure to prevent low return water temperature to the boiler could cause corrosion of the boiler sections or burners, resulting in severe personal injury, death or substantial property damage.

**WARNING** Radiant heating system piping should include a means of regulating the boiler return water temperature **AND** the system supply temperature (such as provided by an injection pumping control).

- Boiler return water temperature will be adequately controlled using the methods shown in this manual provided the system supply temperature is relatively constant.
- DO NOT apply the methods in this manual if the system is equipped with an outdoor reset control. Instead, provide controls and piping which can regulate the boiler return water temperature at no less than 130 °F regardless of system supply temperature. Contact your Weil-McLain representative for suggested piping and control methods.
- Failure to prevent cold return water temperature to the boiler could cause corrosion damage to the sections or burners, resulting in possible severe personal injury, death or substantial property damage.

### Adjust valves as follows (Fig. 7A & 7B only):

1. Start with valve 7a fully closed and 7b fully open.
2. Gradually open valve 7a while closing valve 7b until the temperature at **gauge 8** reads 60 °F higher than gauge 4a.  
A minimum 60 °F temperature rise through the boiler assures a low enough flow rate and high enough average temperature to prevent condensation even with low system return water temperature.
3. Valve 7a regulates the system flow rate, while valve 7b regulates the boiler flow rate.
4. The boiler-mounted temperature/pressure gauge may be used in place of a separate gauge 8.



## Alternate by-pass piping arrangements for RADIANT HEATING SYSTEMS or CONVERTED GRAVITY SYSTEMS

Alternatives to Figures 6A and 6B  
 (Do not apply to systems using outdoor reset controls)

**Boiler by-pass — Zoning with circulators**

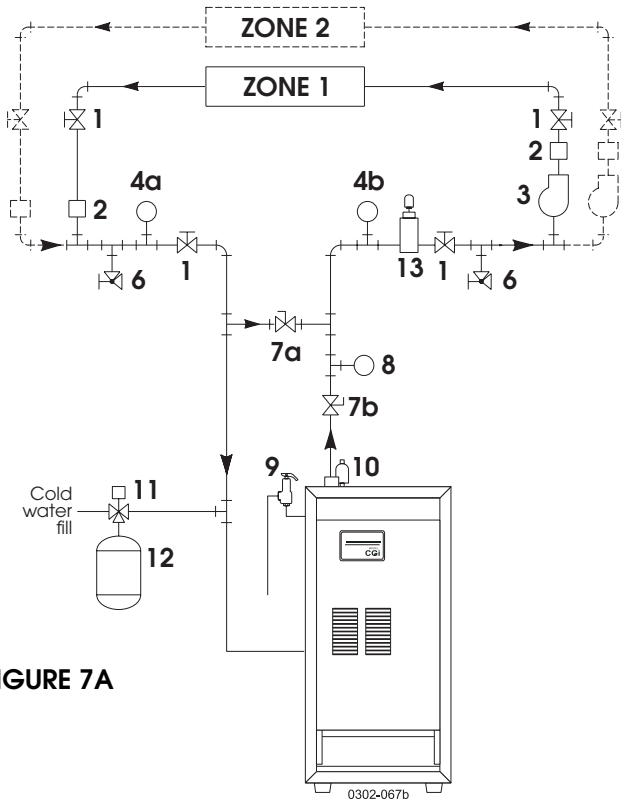

**FIGURE 7A**

**Boiler by-pass — Zoning with zone valves**

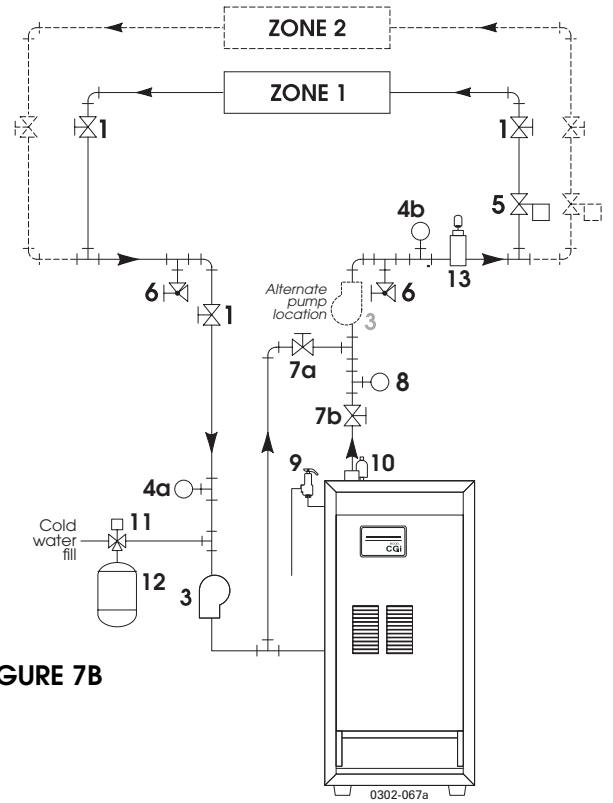

**FIGURE 7B**

**Legend** (For Figures 7A and 7B) .....

- |  |   |
|--|---|
| <ul style="list-style-type: none"> <li><b>1</b> Isolation valve</li> <li><b>2</b> Flow/check valve</li> <li><b>3</b> Circulator</li> <li><b>4</b> System temperature gauges</li> <li><b>5</b> Zone valve</li> <li><b>6</b> Drain valve</li> <li><b>7</b> System temperature valves<br/>(see instructions at left for adjusting valves)</li> <li><b>8</b> Blend temperature gauge</li> <li><b>9</b> Relief valve</li> <li><b>10</b> Automatic air vent</li> </ul> | <ul style="list-style-type: none"> <li><b>11</b> Fill valve</li> <li><b>12</b> Diaphragm expansion tank<br/>(see Figure 3B if using closed type expansion tank. DO NOT use automatic air vent with closed type expansion tank.)</li> <li><b>13</b> In-line air separator and automatic vent, if used<br/>(Note that the fill valve must always be connected to the expansion tank, regardless of location of expansion tank, circulator or air separator.)</li> </ul> |
|--|---|



## Piping for CONVERTED GRAVITY SYSTEMS — Alternate by-pass piping arrangement for large water content systems

Figure 8 is an alternate piping method that provides return water temperature control for boilers installed on large water content systems (converted gravity or steam systems).

Do not apply the piping of Figure 8 on radiant heating systems. It provides no method of regulating the water temperature provided to the system, and could result in excessive water temperature in the radiant tubing.

This piping method is called a "system by-pass" because part of the pump flow by-passes the system (through valve 7a). This by-passed hot water from the boiler outlet mixes with cooler system return water temperature in order to provide minimum 130 °F return water to the boiler. Valve 7b will most often be full open, but may need to be slightly closed on some low pressure drop systems in order to cause enough flow through valve 7a.

System by-pass piping as shown in Figure 8 can be used with either zone-valve zoning or circulator zoning. When used with circulator zoning, however, the boiler circulator, item 3, must be piped as shown. It cannot be used as one of the zoning circulators.

Do not apply system by-pass piping if the reduced flow in the system could cause poor heat distribution. That is, system by-pass piping reduces the flow in the system and increases the water temperature supplied to the system. This can cause increased heat from radiators at the beginning of the system and reduced heat from radiators near the end of the system.

**WARNING** Failure to prevent low return water temperature to the boiler could cause corrosion of the boiler sections or burners, resulting in severe personal injury, death or substantial property damage.

**WARNING** Radiant heating system piping should include a means of regulating the boiler return water temperature **AND** the system supply temperature (such as provided by an injection pumping control).

- Boiler return water temperature will be adequately controlled using the methods shown in this manual provided the system supply temperature is relatively constant.
- DO NOT apply the methods in this manual if the system is equipped with an outdoor reset control. Instead, provide controls and piping which can regulate the boiler return water temperature at no less than 130 °F regardless of system supply temperature. Contact your Weil-McLain representative for suggested piping and control methods.
- Failure to prevent cold return water temperature to the boiler could cause corrosion damage to the sections or burners, resulting in possible severe personal injury, death or substantial property damage.

### Adjust valves as follows (Figure 8 only):

1. Start with valve 7a fully closed and 7b fully open.
2. Gradually open valve 7a while closing valve 7b until the temperature at **gauge 8** reads at least 130 °F at all times.
3. Valve 7a regulates the amount of boiler supply water mixed with return water. Valve 7b causes a pressure drop in the system needed to balance flow through valve 7a and the system.
4. The valve adjustment should be done with the system at the coldest expected temperature (60 °F for converted gravity systems or high mass radiant systems).



## Alternate by-pass piping arrangement for CONVERTED GRAVITY (OR STEAM) SYSTEMS

Alternate to Figure 7A/7B — for converted gravity (or steam) systems only  
 (Do not apply to radiant heating systems)

**System by-pass** — Applies to **ANY** zoning method

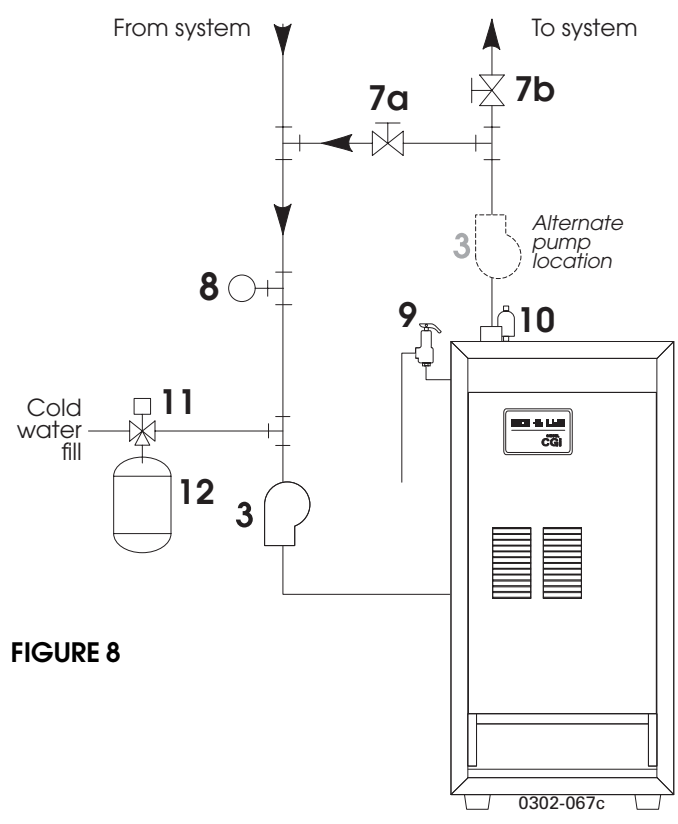

**FIGURE 8**

**Legend** .....

- |  |   |
|--|---|
| <ul style="list-style-type: none"> <li><b>1</b> Isolation valve</li> <li><b>2</b> Flow/check valve</li> <li><b>3</b> Circulator</li> <li><b>4</b> System temperature gauges</li> <li><b>5</b> Zone valve</li> <li><b>6</b> Drain valve</li> <li><b>7</b> System temperature valves<br/>(see instructions at left for adjusting valves)</li> <li><b>8</b> Blend temperature gauge</li> <li><b>9</b> Relief valve</li> <li><b>10</b> Automatic air vent</li> </ul> | <ul style="list-style-type: none"> <li><b>11</b> Fill valve</li> <li><b>12</b> Diaphragm expansion tank<br/>(see Figure 3B if using closed type expansion tank. DO NOT use automatic air vent with closed type expansion tank.)</li> <li><b>13</b> In-line air separator and automatic vent, if used<br/>(Note that the fill valve must always be connected to the expansion tank, regardless of location of expansion tank, circulator or air separator.)</li> </ul> |
|--|---|

# Venting and Combustion Air



**DANGER** Boiler must be vented and supplied with combustion and ventilation air as described in these instructions. Failure to do so will cause severe personal injury or death.

## Venting method definitions:

1. **Chimney draft venting** - Category I appliance. (non-positive vent static pressure and vent gas temperature that avoids excessive condensate production in vent). See page 19. Chimney draft installation using:
  - a. Vent connector (single or doublewall) sized to eliminate positive pressure in vent system. Diameter increases immediately at boiler.
  - b. Doublewall metal vent (B-vent) or chimney with liner approved by National Fuel Gas Code, ANSI Z223.1-latest edition, or in Canada, CAN/CGA B149.1 or B149.2 Installation Code.
2. **Direct exhaust** - Category III appliance (positive vent static pressure and vent gas temperature that avoids excessive condensate production in vent). See pages 20-28. Direct exhaust installation using:
  - a. Vent pipe specified in these instructions.
  - b. Vent termination through outside wall, roof or unused chimney. Tight chimney areas will make vent joint construction very difficult.

## Combustion and ventilation air source:

Combustion and ventilation air openings must comply with Section 5.3 of National Fuel Gas Code ANSI Z223.1-latest edition, or applicable building codes. Canadian installations must comply with CAN/CGA B149.1 or B149.2 Installation Code.

**WARNING** Provide adequate combustion and ventilation openings to assure proper combustion, and prevent possibility of flue gas spillage and carbon monoxide emissions, which can result in severe personal injury or death. Do not install exhaust fan in boiler room.

For boilers located in confined rooms or in buildings of tight construction:

1. A confined room, as defined by National Fuel Gas Code, is less than 50 cubic feet per 1000 Btuh input of all appliances in the room.

2. When air is taken from inside the building — Provide 2 permanent openings, one within 12 inches of ceiling, one within 12 inches of floor. Minimum dimension of each rectangular opening should be at least 3 inches. Each opening must be at least 1 square inch per 1000 Btuh input of all fuel burning appliances (plus requirements for any equipment that can pull air from room, including clothes dryer and fireplace), but not less than 100 square inches. Openings must freely connect with areas having adequate air flow from outside.
3. When air is taken from outdoors — follow either method described below:
  - a. Provide 2 permanent openings, one within 12 inches of ceiling, one within 12 inches of floor. Minimum dimension of each rectangular opening should be at least 3 inches. Openings must connect directly or by ducts with outdoors or spaces (crawl or attic) that freely connect to outside air. Size as listed below:
    - 1) Through outside wall or vertical duct - at least 1 square inch per 4000 Btuh input of all fuel burning appliances (plus requirements for any equipment that can pull air from room, including clothes dryer and fireplace).
    - 2) Through horizontal ducts - 1 square inch per 2000 Btuh input of all fuel burning appliances (plus requirements for any equipment that can pull air from room, including clothes dryer and fireplace).
    - 3) Other size ducts must comply with local codes.
  - b. When boiler clearances from sides and back are at least 1 inch and from the front at least 6 inches, 1 permanent opening may be provided within 12 inches from ceiling. Opening must connect directly or by ducts with outdoors or spaces (crawl or attic) that freely connect to outside air. Size as listed below:
    - 1) 1 square inch per 3000 Btuh of total input rating all fuel burning appliances (plus requirements for any equipment that can pull air from room, including clothes dryer and fireplace) . . . **and** . . .
    - 2) Not less than the sum of all the areas of all vent connectors in the room.

# Chimney Draft Venting



## General venting information:

1. Use doublewall metal vent (B-vent) or chimney with liner as required by National Fuel Gas Code, ANSI Z223.1-latest edition, or in Canada, CAN/CGA B149.1 or B149.2 Installation Code.
2. To prevent downdrafts, chimney should extend at least 3 feet above highest point where it passes through a roof and at least 2 feet higher than any portion of a building within a horizontal distance of 10 feet.
3. To vent with another appliance, see National Fuel Gas Code, ANSI Z223.1-latest edition, or in Canada, CAN/CGA B149.1 or B149.2 Installation Code.
4. **DANGER** Inspect existing chimney before installing boiler. Failure to clean or replace perforated pipe or lining will cause severe personal injury or death.
5. Do not connect breeching to any portion of a mechanical draft system that can operate under positive pressure.
6. Maintain minimum 2" clearance from combustible materials to vent pipe.
7. Do not use chimney with an open fireplace.
8. Make horizontal runs as short as possible. Long runs can cause condensation.
9. When longer runs are used, support pipe with appropriate hangers.
10. To prevent blockage, do not vent into bottom of chimney.
11. Vent pipe must not go beyond inside wall of chimney.
12. Vent passing through floors or ceilings must be firestopped.
13. See Figure 9 and Table 4 to connect boiler to venting system.

Boiler Model	"D" Minimum Vent connector diameter
CGi - 25	4"
CGi - 3	4"
CGi - 4	5"
CGi - 5	5"
CGi - 6	5"
CGi - 7	5"

\* See **WARNING** below regarding sizing and applicable codes.

**WARNING** Vent sizing given in Table 4 is only a general guideline. The vent connector and chimney must be designed, sized and constructed in compliance with all applicable codes, including:

U. S. — National Fuel Gas Code, ANSI Z223.1-latest edition.

Canada — CAN/CGA B149.1 or B149.2 Installation Code.

Failure to correctly size and install the vent system could result in severe personal injury, death, or substantial property damage.

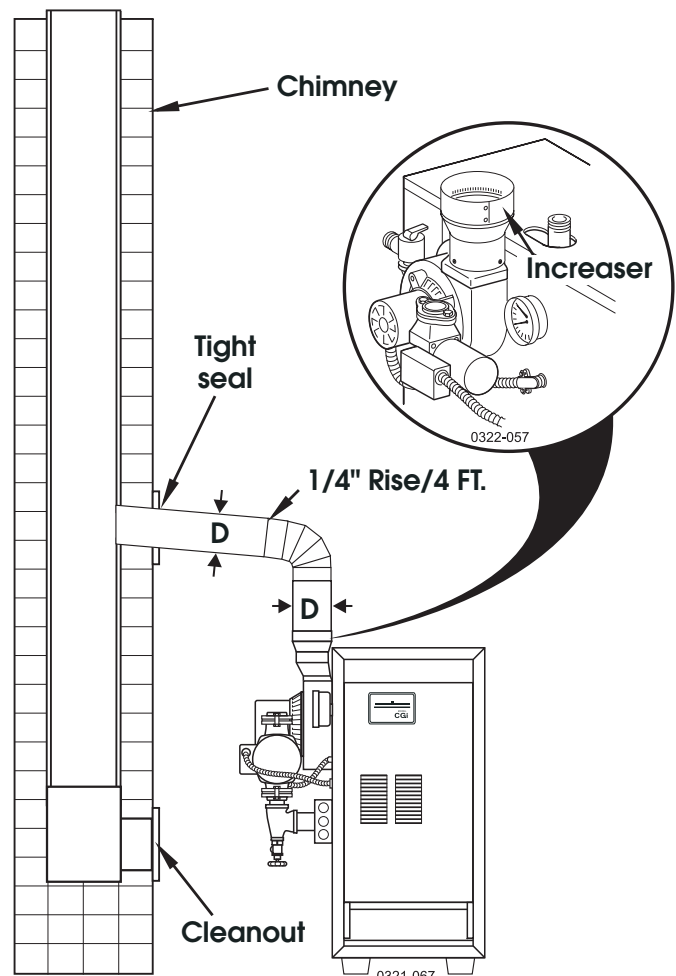

Chimney draft venting  
 FIGURE 9

# Direct Exhaust Vent Location



**WARNING** Follow instructions on this page when determining vent location to avoid possibility of severe personal injury, death or substantial property damage.

1. Gases will form white plume in winter. Plume could obstruct window view.
2. Prevailing winds could cause freezing of condensate and water/ice buildup on building, plants or roof.
3. Locate or guard vent to prevent accidental contact by people or pets.
4. Do not terminate vent in window well, stair well, alcove, courtyard, or other recessed areas.
5. Vent termination must be located more than 4 feet below or 4 feet horizontally from any door, window or gravity air inlet into any building, and more than 1 foot above grade or anticipated snowline. In addition, vent termination must be at least 7 feet above public walkway and 3 feet above any forced air inlet within 10 feet. Stay well away from trees, shrubs, and decorative items. Site conditions may dictate greater clearances. See Figure 10.
6. Vent must terminate at least 4 feet horizontally, and in no case above or below, unless a 4 foot horizontal distance is maintained, from electric meters, gas meters, regulators, relief valves, and other equipment.
7. Locate or guard vent to prevent condensate from damaging exterior finishes.
8. Do not extend exposed vent pipe outside of building. Condensate could freeze and block

9. Terminate vent at least 6 feet away from adjacent walls.
10. Do not terminate vent closer than 5 feet below roof overhang or parapet.
11. Do not terminate vent above any door, window or gravity air inlet into any building. Condensate can freeze, causing ice formations.
12. Do not connect:
  - Any other appliance to vent pipe.
  - Multiple boilers to a common vent pipe.
13. Do not wrap or insulate vent pipe and fittings.
14. Winds over 40 mph can cause nuisance boiler shutdown if boiler is sidewall vented.
15. Canadian installations - Do not terminate vent less than 6 feet from another combustion air inlet or less than 3 feet from any other building opening or any gas service regulator.
16. For location of vertical termination, see vent pipe manufacturer's instructions.

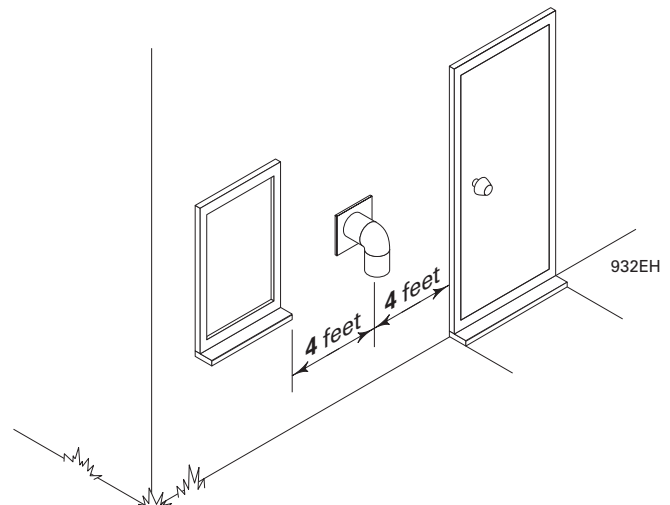
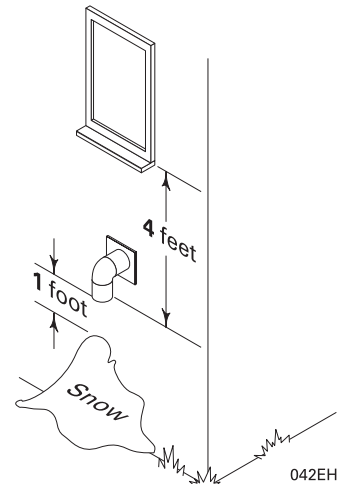
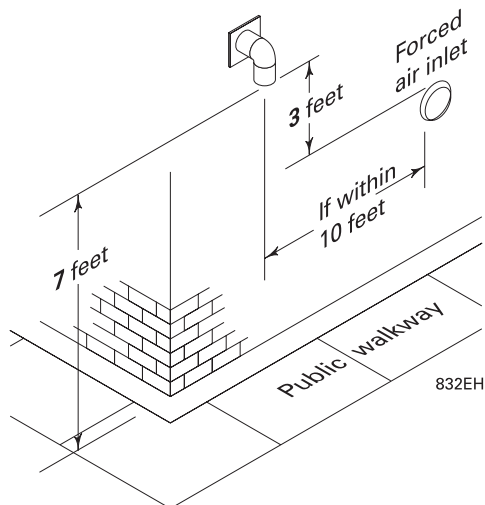

Vent termination locations  
 FIGURE 10

# Direct Exhaust with AL29-4C



## Select vent pipe:

The following special gas vent systems comply with UL-1738 and ULC-S636 Standards and are certified by AGA and CGA as the only systems suitable for use with CGi boilers:

- Heat-Fab, Inc. Saf-T Vent®
- Flex-L International, Inc. StaR-34
- Z-Flex Z-Vent II
- ProTech System FasNSeal™

## Connect starter to boiler:

1. Follow information on pages 18 and 20 before proceeding.
2. Follow national, state, local or provincial codes when venting the CGi boiler.

3. Limitations to use of Heat-Fab, Inc. Saf-T Vent®; Flex-L International, Inc. StaR-34; Z-Flex Z-Vent II; or ProTech Systems FasNSeal™ Special Gas Vent Systems –
  - a. Do not mix types or manufacturers of vent materials.
  - b. Maintain minimum 2" clearance from combustible materials to vent pipe.
4. Connect starter to blower housing outlet as shown in Figure 11, 12, 13 or 14.
  - a. Seal with sealant specified by vent pipe manufacturer, using 3/8" bead (not required for FasNSeal™).
  - b. Tighten strap at band clamp screw until strap is snug around blower housing.

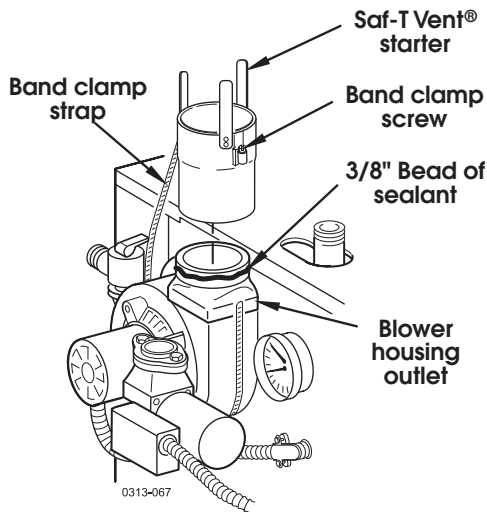

**Saf-T Vent® Starter**  
**FIGURE 11**

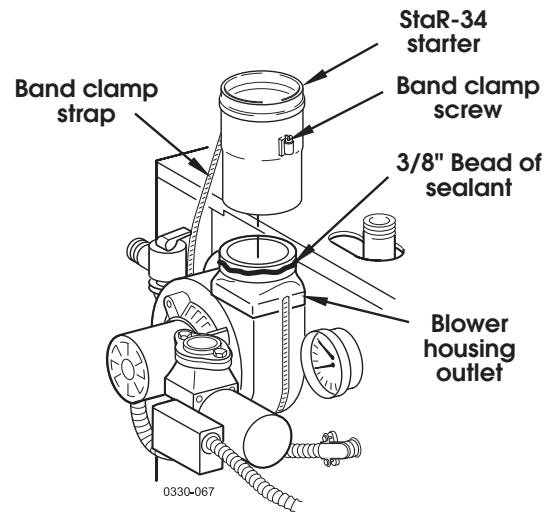

**StaR-34 Starter**  
**FIGURE 12**

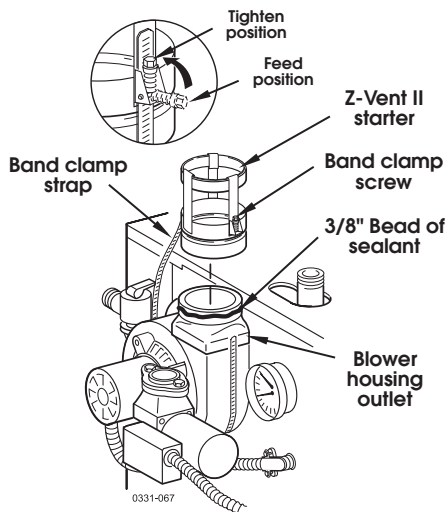

**Z-Vent II Starter**  
**FIGURE 13**

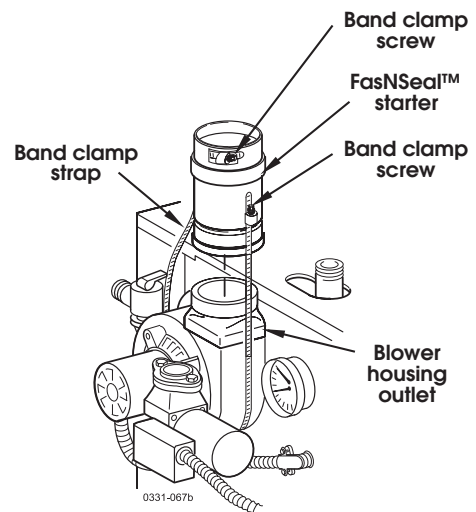

**FasNSeal™ Starter**  
**FIGURE 14**

# Direct Exhaust with AL29-4C



## Construct vent run:

- Follow vent pipe manufacturer's instructions to construct vent run and for methods of supporting vent runs.
  - Do not mix types or manufacturers of vent materials.
  - Clean joints before sealing. See vent pipe manufacturer's instructions to clean joints. Use their specified sealant. Do not use screws.
  - Install vent pipe with seams on top of vent runs.
  - Saf-T Vent® and StaR-34 only - If needed, use slip connector to adjust for nonstandard pipe lengths. See vent pipe manufacturer's instructions for use.

**WARNING** Sealant recommended by vent pipe manufacturer must be used as indicated. Vent piping must be sealed gas-tight to prevent possibility of flue gas spillage and carbon monoxide emissions, resulting in severe personal injury or death.

Maximum number of elbows*	1	2	3	4	5	6
<b>Maximum length — Feet</b>						
<b>CGi- 3 through 6</b>	<b>55</b>	<b>48</b>	<b>41</b>	<b>34</b>	<b>27</b>	<b>20</b>
<b>CGi-7</b>	<b>35</b>	<b>28</b>	<b>21</b>	<b>14</b>	<b>7</b>	<b>--</b>

\* Do not include termination elbow when counting maximum number of elbows.

Description	Saf-T Vent®		StaR-34 ▲	Z-Vent II ▲	FasNSeal™ ▲
	Weil-McLain Part Number I	Saf-T Vent® Part Number ▲			
CGi Starter	699-999-015	73WMCGIS	SRAWCG3	SVEWMFA03	FSA-WEIL-CGI
Termination Coupling with Screen	699-999-001	73WMTERM	--	SVSTPX03	FSB3S
Termination Elbow with Screen	699-999-069	1314TERM	SRTE-03	SVSTEX0390	FSTE90
45° Elbow	699-999-010	7311GC	SRE4503	SVEEWC0345	FSEL4503
90° Elbow	699-999-011	7314GCTR	SRE9003	SVEEWC0390	FSEL9003
6" Pipe	699-999-003	7301GC	SR06P03	SVEPWC03.5	FSVL603
12" Pipe	699-999-004	7302GC	SR12P03	SVEPWC0301	FSVL1203
18" Pipe	699-999-005	7304GC	--	SVEPWC0318	FSVL1803
24" Pipe	699-999-006	7305GC	SR24P03	SVEPWC03	FSVL2403
36" Pipe	--	--	SR36P03	SVEPWC0303	FSVL3603
37 1/2" Pipe	699-999-007	7307GC	--	--	--
48" Pipe	--	--	--	SVEPWC0304	--
49 1/2" Pipe	699-999-008	7308GC	--	--	--
60" Pipe	699-999-012	7360GC	SR60P03	SVEPWC0305	--
Slip Connector (Note 1)	699-999-009	7324GC9	SRSJ03	--	--
Horizontal Support	699-999-016	7323GC	--	--	FSSH
Horizontal Drain Tee	699-999-014	7320GC	SRTDH03	SVEDWC03	FSHDT3
Joiner Band	--	--	SRJB-14	--	--
Sealant	As specified by individual vent pipe manufacturer				Not required

NOTE1 — Use to adjust for nonstandard pipe lengths and Saf-T Vent® only, before termination coupling to terminate run.

- I — Weil-McLain part number — parts available through Weil-McLain distributor.
- ▲ — Vent pipe manufacturer part number — parts available through vent pipe manufacturer.

# Direct Exhaust with AL29-4C

## Venting through wall with Saf-T Vent® -

1. Do not mix types or manufacturers of vent materials.
2. Maintain minimum 2" clearance from combustible materials to vent pipe.
3. See Figures 15 and 16. Vent must terminate at least one foot above anticipated snowline. Vent must be terminated only with a Saf-T Vent® elbow with integral screen or elbow with termination coupling with screen.
4. Do not seal slip connector to inside or outside plate.
5. If passing through noncombustible wall, provide hole diameter large enough to insert the slip connector.
6. Install inline drain section as close as possible to boiler, in first horizontal run. See Figure 15.

**WARNING** Condensate drain line — use only silicone tubing rated for at least 400 °F for the condensate drain line. Using any other material could cause flue gas leakage, potentially resulting in severe personal injury, death or substantial property damage.

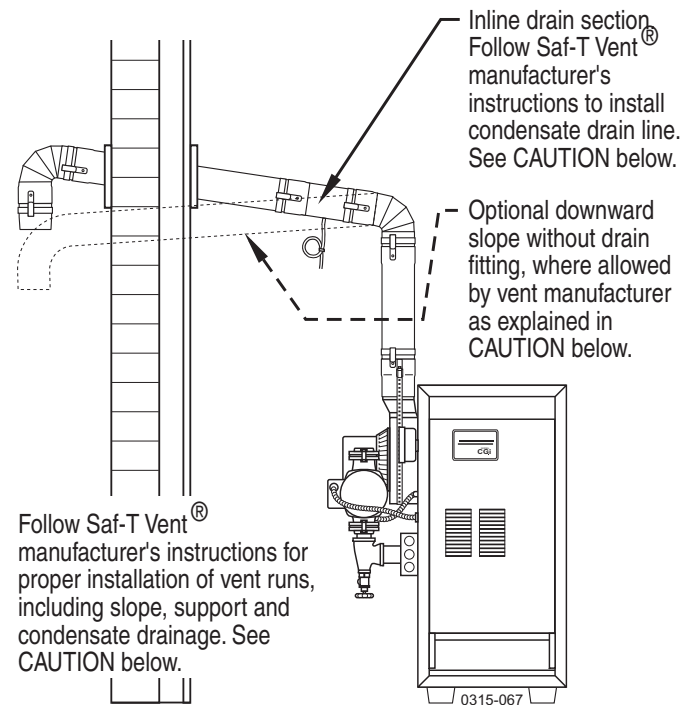

Horizontal venting with Saf-T Vent®  
 FIGURE 15

**CAUTION** On some installations, the condensate drain fitting may be omitted, provided:

- Vent manufacturer shows this option in their instructions.
- Vent is sloped **toward termination** as shown by dotted lines in drawing above.
- The vent is installed per Weil-McLain and vent manufacturer instructions.

Condensate drippage from such vents may accumulate on the ground below. Consider traffic in the area to avoid hazard due to ice accumulation.

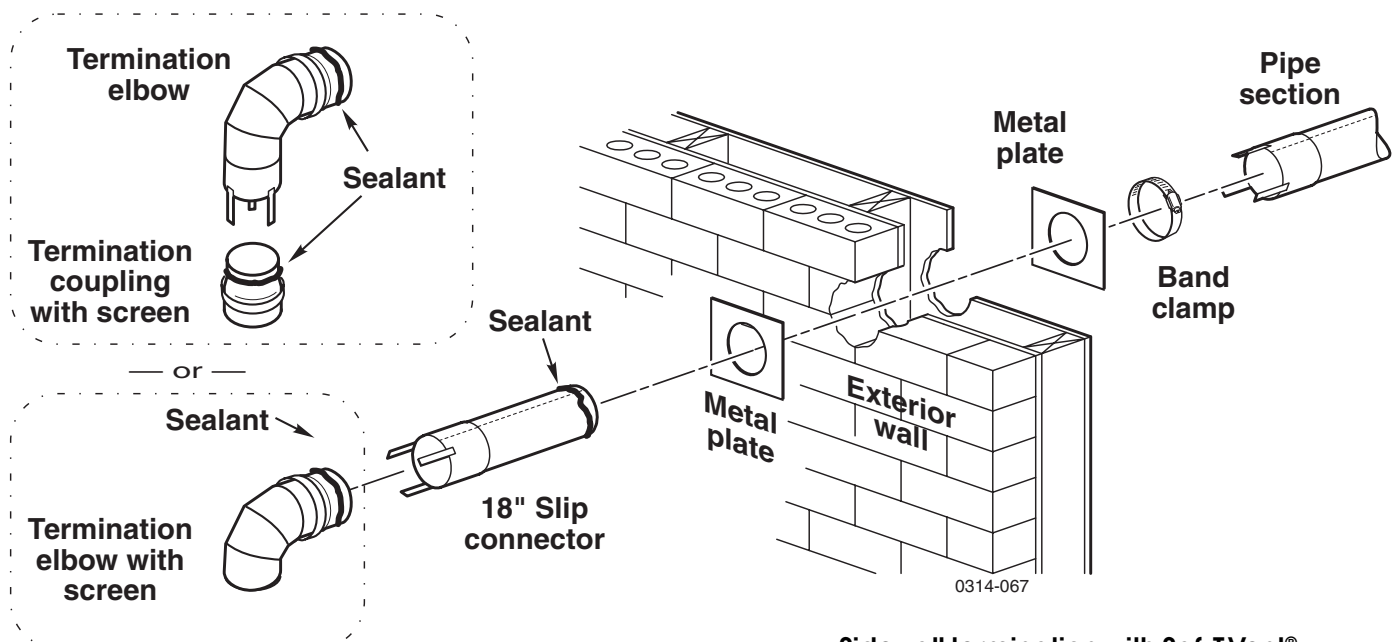

Sidewall termination with Saf-T Vent®  
 (combustible wall shown)  
 FIGURE 16

# Direct Exhaust with AL29-4C

## Venting through wall with StaR-34 -

1. Do not mix types or manufacturers of vent materials.
2. Maintain minimum 2" clearance from combustible materials to vent pipe.
3. See Figures 17 and 18. Vent must terminate at least one foot above anticipated snowline. Vent must be terminated only with StaR-34 elbow with integral screen.
4. Do not seal vent pipe to inside or outside plate.
5. Install horizontal drain tee as close as possible to boiler, in first horizontal run. See Figure 17.

**WARNING** Condensate drain line — use only silicone tubing rated for at least 400 °F for the condensate drain line. Using any other material could cause flue gas leakage, potentially resulting in severe personal injury, death or substantial property damage.

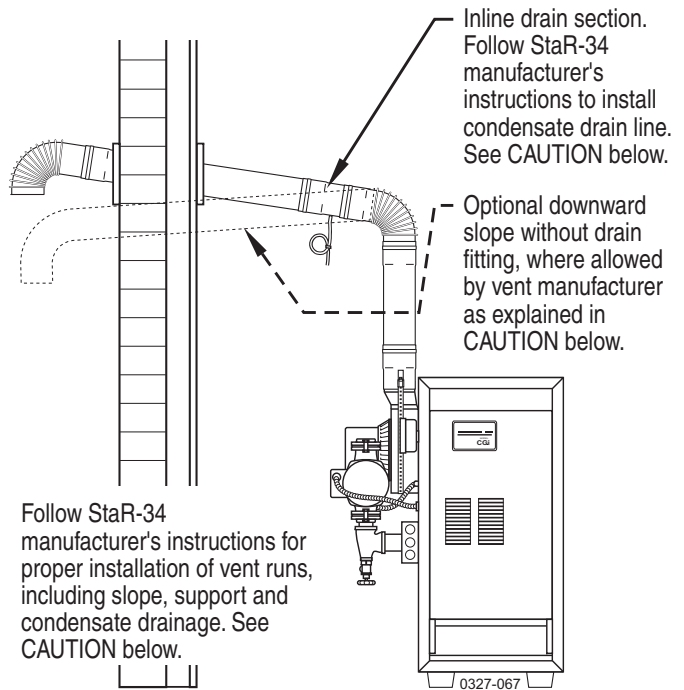

**Horizontal venting with StaR-34**  
**FIGURE 17**

**CAUTION** On some installations, the condensate drain fitting may be omitted, provided:

- Vent manufacturer shows this option in their instructions.
- Vent is sloped **toward termination** as shown by dotted lines in drawing above.
- The vent is installed per Weil-McLain and vent manufacturer instructions.

Condensate drippage from such vents may accumulate on the ground below. Consider traffic in the area to avoid hazard due to ice accumulation.

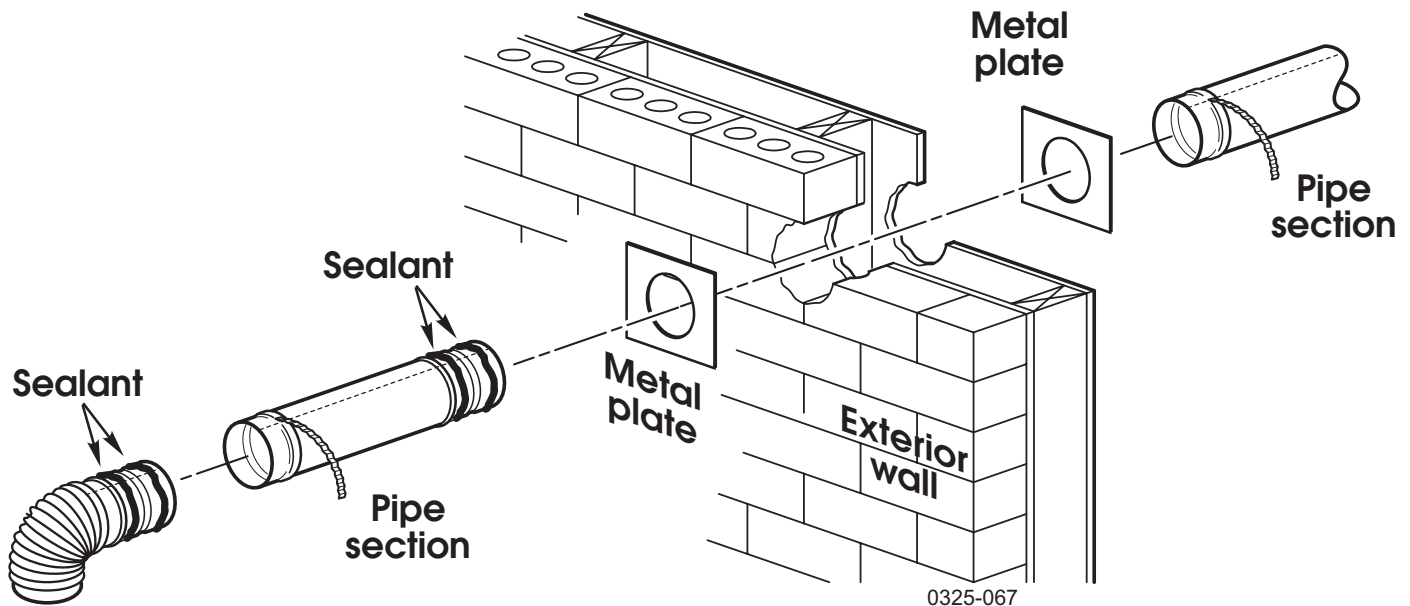

**Termination elbow with screen**

**Sidewall termination with StaR-34**  
 (combustible wall shown)  
**FIGURE 18**

# Direct Exhaust with AL29-4C

## Venting through wall with Z-Vent II -

1. Do not mix types or manufacturers of vent materials.
2. Maintain minimum 2" clearance from combustible materials to vent pipe.
3. See Figures 19 and 20. Vent must terminate at least one foot above anticipated snowline. Vent must be terminated only with a Z-Vent II elbow with integral screen or elbow and termination coupling with screen.
4. Do not seal vent pipe to inside or outside plate.
5. Install horizontal drain tee as close as possible to boiler, in first horizontal run. See Figure 19.

**WARNING** Condensate drain line — use only silicone tubing rated for at least 400 °F for the condensate drain line. Using any other material could cause flue gas leakage, potentially resulting in severe personal injury, death or substantial property damage.

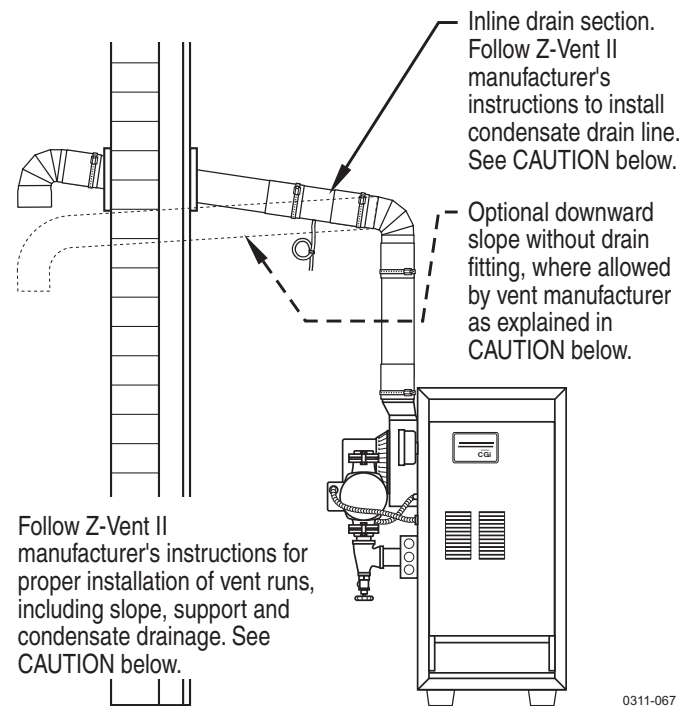

Horizontal venting with Z-Vent II  
**FIGURE 19**

**CAUTION** On some installations, the condensate drain fitting may be omitted, provided:

- Vent manufacturer shows this option in their instructions.
- Vent is sloped **toward termination** as shown by dotted lines in drawing above.
- The vent is installed per Weil-McLain and vent manufacturer instructions.

Condensate drippage from such vents may accumulate on the ground below. Consider traffic in the area to avoid hazard due to ice accumulation.

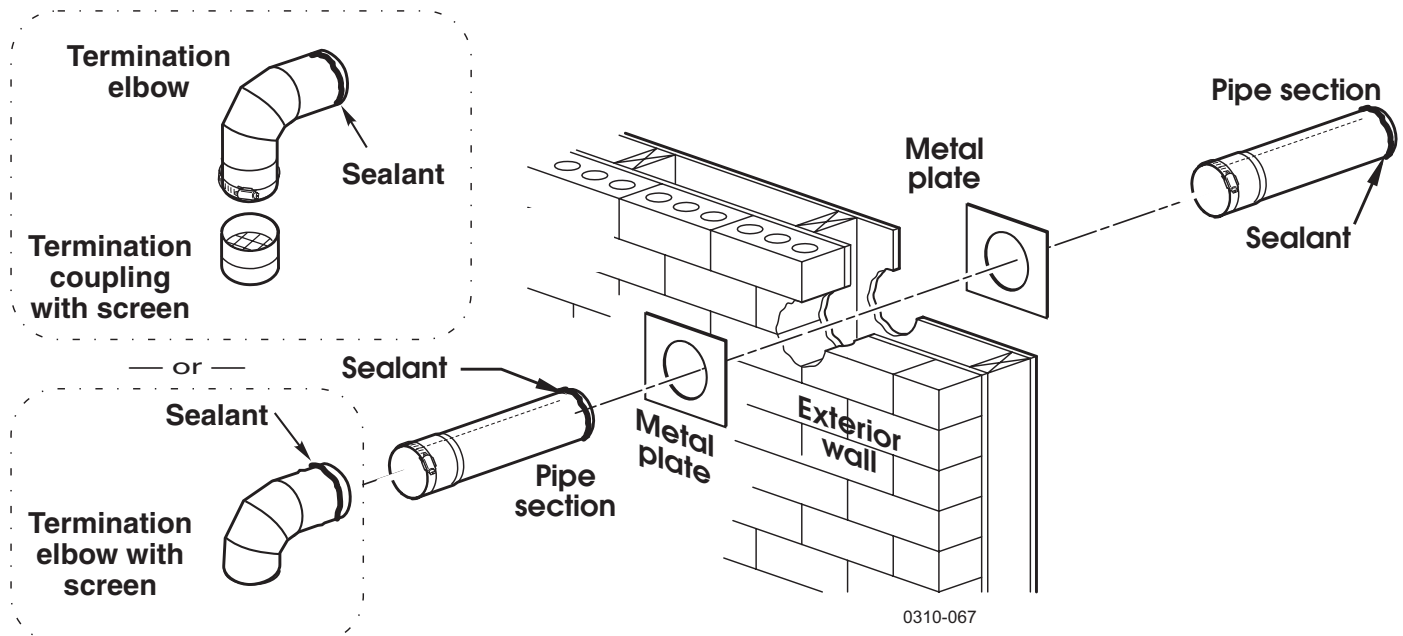

Sidewall termination with Z-Vent II  
 (combustible wall shown)  
**FIGURE 20**

# Direct Exhaust with AL29-4C

## Venting through wall with FasNSeal™ -

1. Do not mix types or manufacturers of vent materials.
2. Maintain minimum 2" clearance from combustible materials to vent pipe.
3. See Figures 21 and 22. Vent must terminate at least one foot above anticipated snowline. Vent must be terminated only with FasNSeal™ elbow with integral screen or elbow and termination coupling with screen.
4. Do not seal vent pipe to inside or outside plate.
5. Install horizontal drain tee as close as possible to boiler, in first horizontal run. See Figure 21.

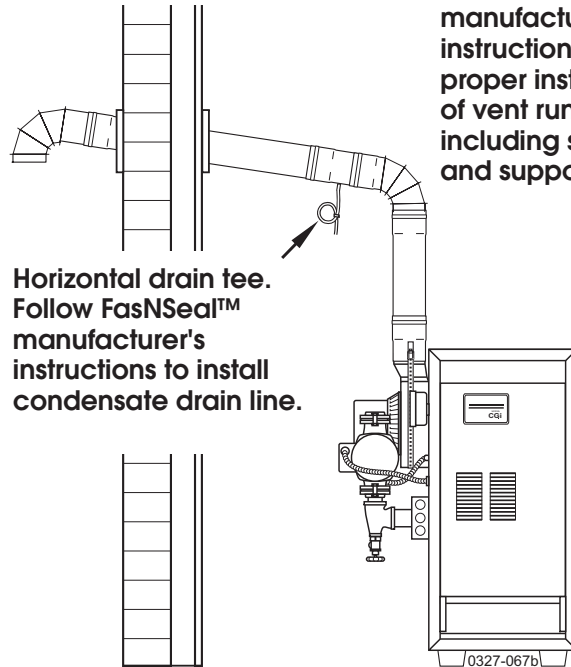

Follow FasNSeal™ manufacturer's instructions for proper installation of vent runs, including slope and support.

Horizontal venting with FasNSeal™  
 FIGURE 21

**WARNING** Condensate drain line — use only silicone tubing rated for at least 400 °F for the condensate drain line. Using any other material could cause flue gas leakage, potentially resulting in severe personal injury, death or substantial property damage.

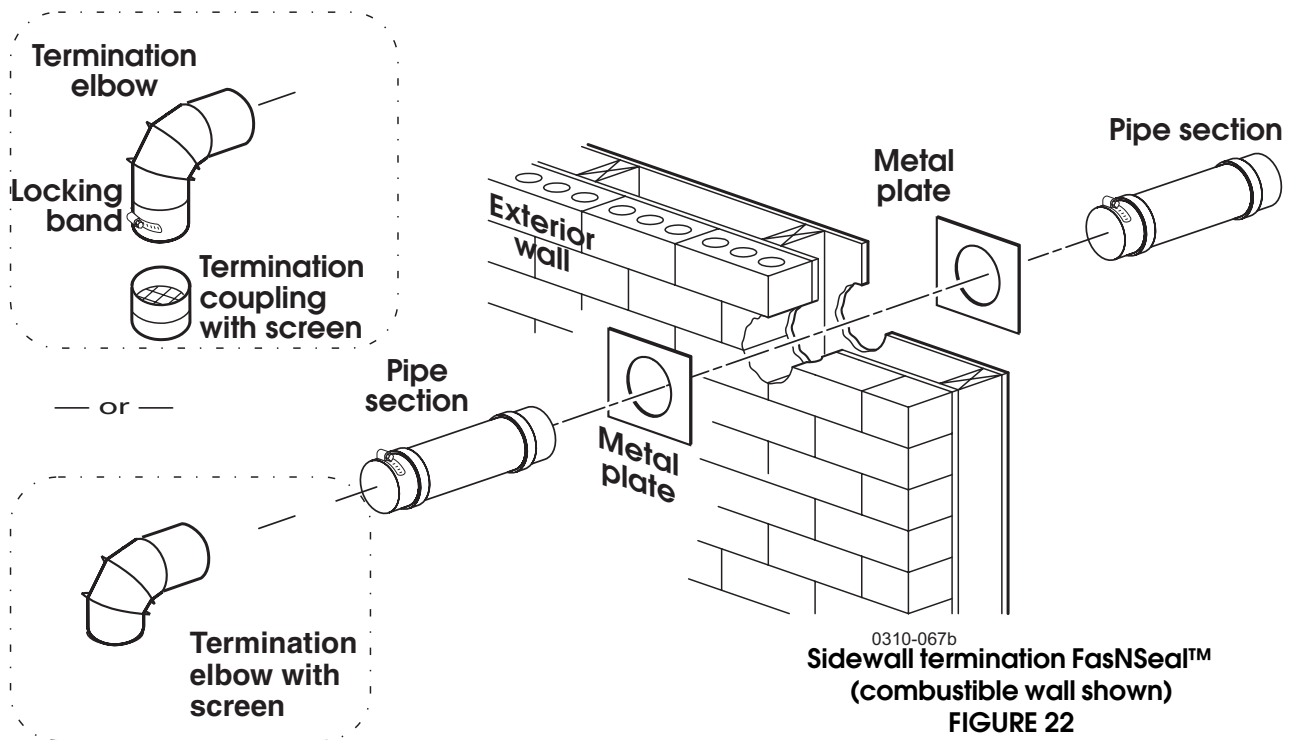

## Venting through roof - Saf-T Vent®

1. Do not mix types or manufacturers of vent materials.
2. Maintain minimum 2" clearance from combustible materials to vent pipe.
3. Follow vent manufacturer's instructions for method to vent through roof. See Figure 23.
  - a. Vent pipe must extend through roof flashing, jacket or thimble.
  - b. Vent may pass through floor, inside wall or concealed space when installed according to vent pipe manufacturer's instructions.
4. Install drain tee as close as possible to boiler, in first horizontal run. See Figure 23.

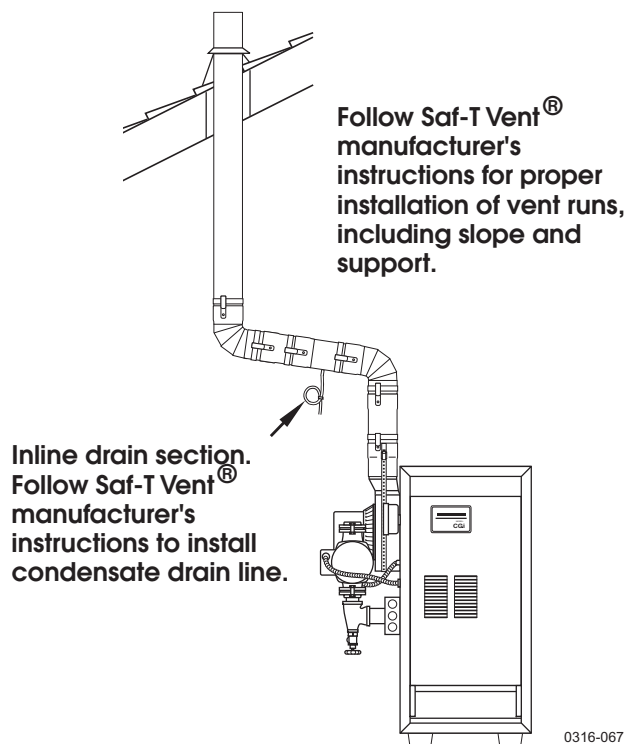

Venting through roof with Saf-T Vent®  
**FIGURE 23**

## Venting through roof - StaR-34 Vent

1. Do not mix types or manufacturers of vent materials.
2. Maintain minimum 2" clearance from combustible materials to vent pipe.
3. Follow vent manufacturer's instructions for method to vent through roof. See Figure 24.
  - a. Vent pipe must extend through roof flashing, jacket or thimble.
  - b. Vent may pass through floor, inside wall or concealed space when installed according to vent pipe manufacturer's instructions.
4. Install drain tee as close as possible to boiler, in first horizontal run. See Figure 24.

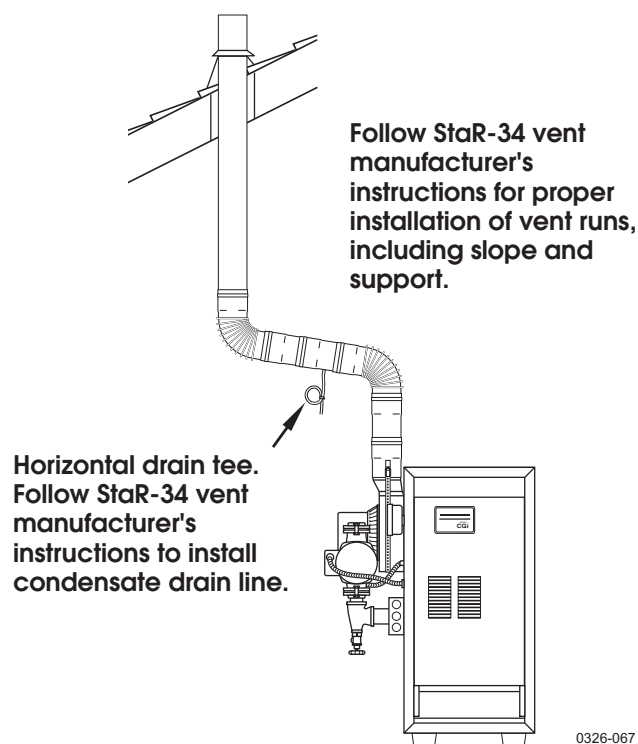

Venting through roof with StaR-34 Vent  
**FIGURE 24**

**WARNING**

Condensate drain line — A condensate drain fitting is always required for through-the-roof vents. Use only silicone tubing rated for at least 400 °F for the condensate drain line. Using any other material could cause flue gas leakage, potentially resulting in severe personal injury, death or substantial property damage.

## Venting through roof - Z-Vent II

1. Do not mix types or manufacturers of vent materials.
2. Maintain minimum 2" clearance from combustible materials to vent pipe.
3. Follow vent manufacturer's instructions for method to vent through roof. See Figure 25.
  - a. Vent pipe must extend through roof flashing, jacket or thimble.
  - b. Vent may pass through floor, inside wall or concealed space when installed according to vent pipe manufacturer's instructions.
4. Install drain tee as close as possible to boiler, in first horizontal run. See Figure 25.

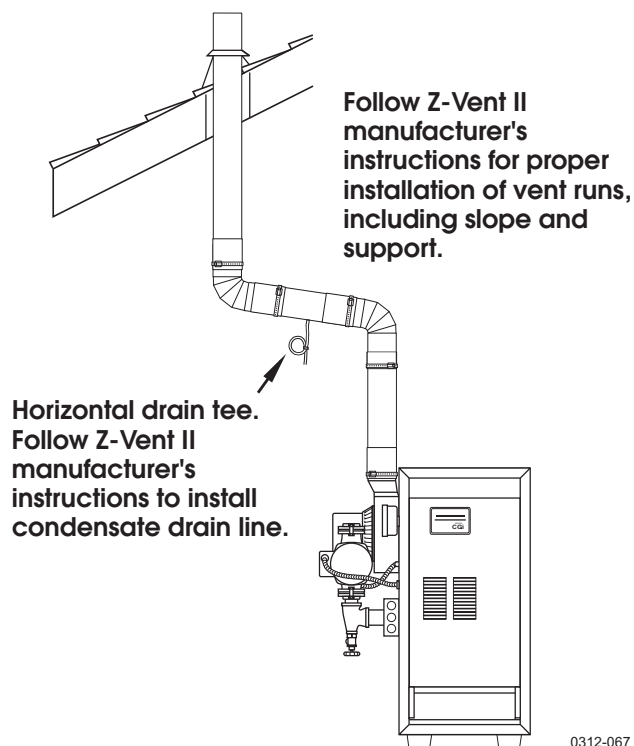

Venting through roof with Z-Vent II  
**FIGURE 25**

## Venting through roof - FasNSeal™

1. Do not mix types or manufacturers of vent materials.
2. Maintain minimum 2" clearance from combustible materials to vent pipe.
3. Follow vent manufacturer's instructions for method to vent through roof. See Figure 26.
  - a. Vent pipe must extend through roof flashing, jacket or thimble.
  - b. Vent may pass through floor, inside wall or concealed space when installed according to vent pipe manufacturer's instructions.
4. Install drain tee as close as possible to boiler, in first horizontal run. See Figure 26.

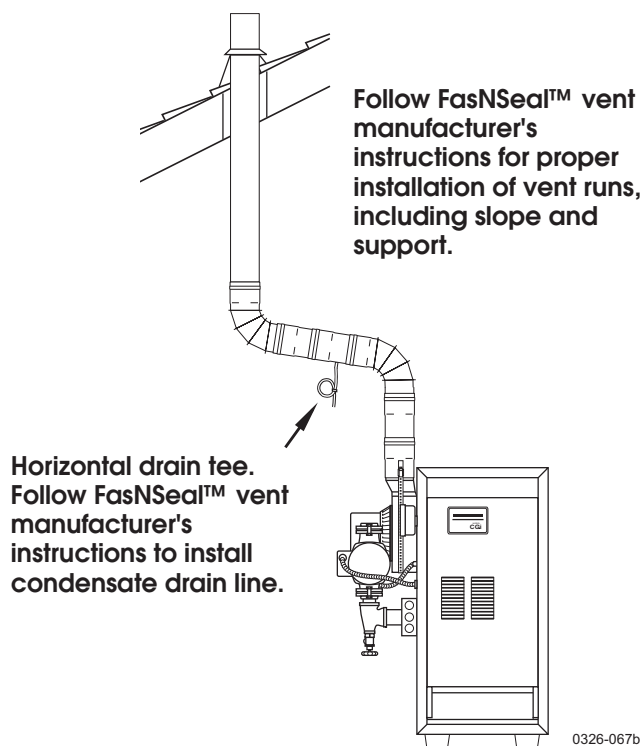

Venting through roof with FasNSeal™  
**FIGURE 26**

**WARNING** Condensate drain line — A condensate drain fitting is always required for through-the-roof vents. Use only silicone tubing rated for at least 400 °F for the condensate drain line. Using any other material could cause flue gas leakage, potentially resulting in severe personal injury, death or substantial property damage.

# Gas Piping



## To install gas piping:

1. Remove jacket front panel and refer to Figure 27 to pipe gas to boiler.
  - a. Install drip leg at inlet of gas connection to boiler. Where local utility requires drip leg to be extended to the floor, use appropriate length of pipe between cap and tee.
  - b. Install ground joint union for servicing, when required.
  - c. Install manual shutoff valve in gas supply piping outside boiler jacket when required by local codes or utility requirements.
  - d. In Canada, when using manual main shut-off valve, it must be identified by installer.
2. Support piping with hangers, not by boiler or its accessories.
3. Purge all air from gas supply piping.
4. Before placing boiler in operation, check boiler and its gas connection for leaks.

**WARNING** Do not check for gas leaks with an open flame — use the bubble test. Failure to use bubble test or check for leaks can result in severe personal injury, death or substantial property damage.

- a. Close manual main shutoff valve during any pressure testing at less than 13" W.C.
  - b. Disconnect boiler and gas valve from gas supply piping during any pressure testing at greater than 13" W.C.
5. Use pipe dope compatible with propane gases. Apply sparingly only to male threads of pipe joints so that pipe dope does not block gas flow.

**WARNING** Failure to apply pipe dope as detailed above can result in severe personal injury, death or substantial property damage.

6. Follow good piping practices.

## Natural gas:

1. Refer to Table 6 for pipe length and diameter. Base on rated boiler input (divide by 1000 to obtain cubic feet per hour).
2. Inlet gas pressure: 5" W.C. minimum  
13" W.C. maximum  
Manifold gas pressure: 3.5" W.C.
3. Install 100% lockup gas pressure regulator in supply line if inlet pressure exceeds 13" W.C. Adjust for 13" W.C. maximum.

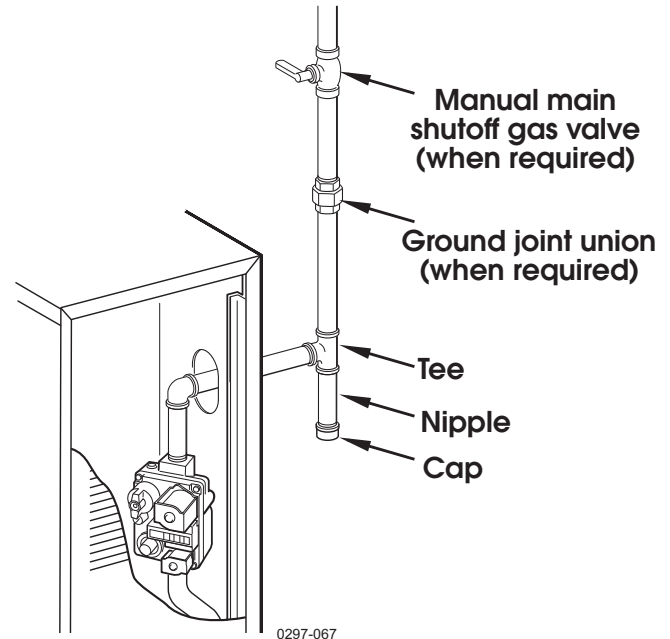

Gas supply piping  
**FIGURE 27**

## Propane gas:

1. Contact gas supplier to size pipes, tanks and 100% lockup gas pressure regulator.
2. Adjust regulator supplied by gas supplier for 13" W.C.
3. Inlet gas pressure: 11" W.C. minimum  
13" W.C. maximum  
Manifold gas pressure: 10" W.C.

TABLE 6 - Natural gas pipe delivery schedule					
Length of pipe in feet	* Capacity of pipe in cubic feet of gas per hour				
	1/2"	3/4"	1"	1-1/4"	1-1/2"
10	132	278	520	1050	1600
20	92	190	350	730	1100
30	73	152	285	590	890
40	63	130	245	500	760
50	56	115	215	440	670
75	45	93	175	360	545
100	38	79	150	305	460
150	31	64	120	250	380

\* Based on 0.60 specific Gravity, 0.30" W.C. pressure drop.  
 NOTE: For additional piping schedules, see ANSI Z223.1.  
 Canadian installations must comply with CAN/CGA B149.1 or B149.2 Installation Code.



## General wiring requirements:

**WARNING** Electric shock hazard. For your safety, turn off electrical power supply at service panel before making any electrical connections. Failure to do so can cause severe personal injury, death or substantial property damage.

- Installations must follow latest editions of national, state, provincial or local codes or regulations including:
  - National Electrical Code.
  - Canadian Electrical Code, C.S.A. C22.1 Part 1.
- Wiring must be N.E.C. Class 1. If original rollout thermal fuse element wire as supplied with boiler must be replaced, type 200°C wire or equivalent must be used. If other original wiring as supplied with boiler must be replaced, type 105°C wire or equivalent must be used.
- Boiler is shipped with controls completely wired.

## Junction box (furnished):

1. Connect 120VAC line voltage as shown on wiring diagram on boiler or on page 37.
2. Fused disconnect or service switch (15 amp. recommended) may be mounted on this box. Some local codes may require or prohibit installation of fused disconnect or service switch on boiler.

## Thermostat:

1. Connect thermostat as shown on wiring diagram on boiler.
2. Install on inside wall away from influences of drafts, hot or cold water pipes, lighting fixtures, television, sunrays or fireplaces.
3. If thermostat has a heat anticipator, set heat anticipator in thermostat to match power requirements of equipment connected to it (such as ignition control and gas valve, zone valve contacts). Wiring diagram on boiler gives setting for ignition control and gas valve. Also see instructions with thermostat.

# Start-Up

## Fill the system:

1. Close manual and automatic air vents and boiler drain cock.
2. Fill to correct system pressure. Correct pressure will vary with each installation. Normal cold water fill pressure for residential systems is 12 psig. Boiler water pH 7.0 to 8.5 is recommended.
3. Open automatic air vent one turn.
4. Open other vents.
  - a. Starting on the lowest floor, open air vents one at a time until water squirts out. Close vent.
  - b. Repeat with remaining vents.
5. Refill to correct pressure.

## Inspect base insulation:

Check to make sure insulation is secure against all four sides of the base. If insulation is damaged or displaced, do not operate boiler. Replace or reposition insulation.

**WARNING** Failure to replace damaged insulation or reposition insulation can result in a fire hazard, causing severe personal injury, death or substantial property damage.

**WARNING**

- POSSIBLE CANCER HAZARD BY INHALATION
- CAN CAUSE RESPIRATORY, SKIN AND EYE IRRITATION

This product contains fiberglass wool and ceramic fiber materials. Airborne fibers from these materials have been listed by the State of California as a possible cause of cancer through inhalation. Apply special care when handling ceramic fiber materials (chamber lining and base insulation). Ceramic fibers can be converted to chrysothalites, a substance listed as a probable cause of cancer.

Suppliers of fiberglass wool products recommend the following precautions be taken when handling these materials.

### Precautionary measures:

- Avoid breathing fiberglass dust and contact with skin and eyes.
- Use NIOSH approved dust/mist respirator.
- Wear long-sleeved, loose fitting clothing, gloves and eye protection.
- Wash work clothes separately from other clothing. Rinse washer thoroughly.
- Operations such as sawing, blowing, tearout and spraying may generate airborne fiber concentration requiring additional protection.

### First aid measures:

- Eye contact - Flush eyes with water to remove dust. If symptoms persist, seek medical attention.
- Skin contact - Wash affected areas gently with soap and warm water after handling.

## To place in operation:

1. Be sure boiler has been completely filled with water.
2. For **natural** gas boilers - Follow operating instruction on boiler to place boiler in operation, then go to step 3.  
For **propane** boilers only - Follow operating instruction on boiler to place boiler in operation, comply with the "WARNING" information below, then go to step 3.

**WARNING** Your propane supplier mixes an odorant with the propane to make its presence detectable. In some instances, the odorant can fade, and the gas may no longer have an odor.

Propane gas can accumulate at floor level. Smell near the floor for the gas odorant or any unusual odor. If you suspect a leak, do not attempt to operate boiler.

- Periodically check the odorant level of your gas.
- Inspect boiler and system at least yearly to make sure all gas piping is gas-tight.
- Consult your propane supplier regarding installation of a gas leak detector. There are some products on the market for this purpose. Your supplier may be able to suggest an appropriate device.

3. If boiler starts, go to step #5.  
If boiler fails to start, go to step #4.
4. If boiler fails to start, check for following conditions:
  - a. Loose connections or blown fuse?
  - b. Limit setting below boiler water temperature?
  - c. Thermostat set below room temperature?
  - d. Gas not turned on at meter and at boiler?
  - e. Incoming natural gas pressure less than 5" W.C. or propane less than 11" W.C.?
  - f. If above fails to eliminate the trouble, refer to "Troubleshooting" section, starting on page 42.
5. Make sure boiler goes through several normal operating cycles.
6. Turn thermostat or operating control to desired setting.

## Check pilot burner flame:

1. Proper pilot flame characteristics:
  - a. Blue flame.
  - b. Inner cone engulfing pilot flame sensor.
  - c. Pilot flame sensor glowing cherry red.
2. Improper pilot flame characteristics:
  - a. Overfired - Large flame lifting or blowing past pilot flame sensor.
  - b. Underfired - Small flame; inner cone not engulfing pilot flame sensor.
  - c. Lack of primary air - Yellow flame tip.
  - d. Incorrectly heated pilot flame sensor.

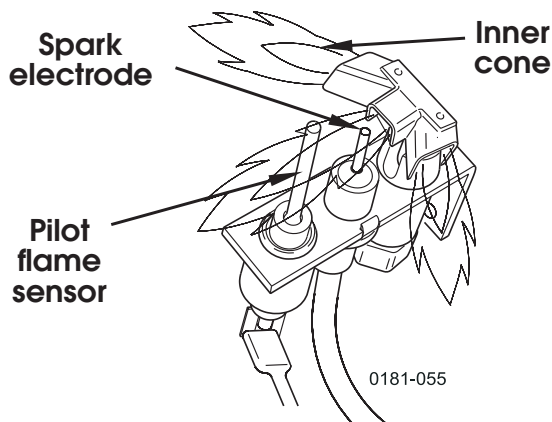

Typical pilot burner flame  
**FIGURE 28**

## Check main burner flames:

1. Proper main burner flames - see Figure 29. Yellow-orange streaks may appear (caused by dust).
2. Improper main burner flame characteristics:
  - a. Overfired - Large flames
  - b. Underfired - Small flames.
  - c. Lack of primary air - Yellow tipping on flames; sooting will occur.

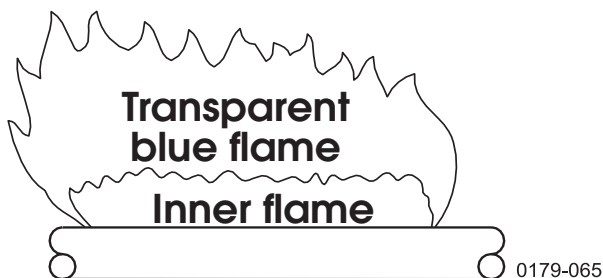

Typical main burner flame  
**FIGURE 29**

## Inspect venting system:

1. Inspect all parts of venting system for deterioration from corrosion, physical damage, sagging. Correct all conditions found.

2. Direct Exhaust boilers - In addition to step #1, check for gas-tight seal at all vent pipe connections, joints and seams.

**WARNING** Seal vent system gas-tight to prevent flue gas spillage and carbon monoxide emissions, which can result in severe personal injury, death or substantial property damage.

## Tips for water systems:

- Check boiler and system piping for leaks. Continual makeup water will reduce boiler life. Minerals can build up in sections, reducing heat transfer and causing cast iron to over heat, resulting in section failure. For unusually hard water areas (above 7 grains hardness), consult local water treatment company.

**DANGER** Failure to maintain recommended pH and repair leaks can cause section iron corrosion, leading to section failure and leaks. Do not use petroleum-based sealing or stop-leak compounds in boiler systems. Severe damage to boiler will occur, resulting in severe personal injury, death or substantial property damage.

- Boiler water pH of 7.0 to 8.5 is recommended; pH level outside that range can damage boiler. Consult local water treatment company.

## When using antifreeze:

- Use antifreeze especially made for hydronic systems. Inhibited propylene glycol is recommended.

**WARNING** Do not use automotive, ethylene glycol, undiluted or petroleum-based antifreeze. Severe personal injury, death or substantial property damage can result.

- 50% solution provides protection to about -30°F. Do not exceed 50% mixture.
- Local codes may require a backflow preventer or actual disconnect from city water supply.
- Determine quantity according to system water content. Boiler water content is listed on page 54 of manual. Percent of solution will affect sizing of heat distribution units, circulator and expansion tank.
- Follow antifreeze manufacturer's instructions.



# Check-Out Procedure

Check off steps as completed.

- 1. Boiler and heat distribution units filled with water.
- 2. Cap on automatic air vent(s), if used, opened one full turn.
- 3. Air purged from system.
- 4. Air purged from gas piping. Piping checked for leaks.
- 5. Correctly sized manifold orifices installed. Check page 7 for correct size.

**DANGER** Correctly-sized manifold orifices must be used. Failure to do so will result in severe personal injury, death or substantial property damage.

- 6. Operating instruction label on boiler followed for proper start-up. Also refer to "To Place in Operation," page 31.
- 7. Proper burner flame observed. Refer to "Check Main Burner Flames," page 32.
- 8. Test limit controls: While burners are operating, move indicator on high limit control below actual boiler water temperature. Burners should go off while circulator continues to operate. Move indicator above boiler water temperature and burners should reignite.
- 9. Test any additional field-installed controls: If boiler has low water cutoff, additional high limit or other controls, test for operation as outlined by manufacturer. Burners should be operating and should go off when controls are tested. When controls are restored, burners should reignite.
- 10. Test ignition system shutoff device: Connect manometer to outlet side of gas valve. Start boiler, allowing for normal start-up cycle to occur and main burners to ignite. With main burners on, manually shut off gas supply at manual main shut-

off gas valve. Burners should go off. Open manual main shutoff gas valve. Manometer should confirm there is no gas flow. Pilot will relight, flame sensing element will sense pilot flame and main burners will reignite.

- 11. High limit control set to design temperature requirements of system.
- 12. For multiple zones, flow adjusted so it is about the same in each zone.
- 13. Thermostat heat anticipator set properly? Refer to "Thermostat," page 30, and wiring diagram on jacket front panel.
- 14. Boiler cycled with thermostat. Raise to highest setting. Boiler should go through normal start-up cycle. Lower to lowest setting. Boiler should go off.
- 15. Measure gas input (for natural gas only):
  - a. Operate boiler for 10 minutes.
  - b. Turn off other appliances.
  - c. At natural gas meter, measure time in seconds required to use one cubic foot of gas.
  - d. Calculate gas input:
 
$$\frac{3600 \times 1000}{\text{number of seconds from step c}} = \text{Btuh}$$
  - e. Btuh calculated should approximate input rating on rating label.
- 16. Check manifold gas pressure by connecting manometer to downstream test tapping on main gas valve. Manifold pressure for natural gas should be 3.5" W.C. and for propane should be 10" W.C.
- 17. Several operating cycles observed for proper operation.
- 18. Room thermostat set to desired room temperature.
- 19. Installation and Service Certificate on this page completed.
- 20. All instructions shipped with this boiler reviewed with owner, returned to envelope and given to owner or displayed near boiler.

---

## Installation and Service Certificate

---

Boiler Model \_\_\_\_\_ Series \_\_\_\_\_ CP Number \_\_\_\_\_ Date installed \_\_\_\_\_

BTU Input \_\_\_\_\_

- Installation instructions followed.
- Check-out sequence performed.
- Above information certified to be correct.
- Information reviewed and left with owner.

Installer \_\_\_\_\_

(Company - Address - Phone)

\_\_\_\_\_

(Installer's signature)

# Suggested Minimum Service



Also refer to additional instructions packed with boiler.  
Verify proper operation after servicing.

## Annual service call by qualified service technician to include:

1. Check burners and flueways; clean if necessary. Refer to "Cleaning Boiler Heating Surfaces" (this page) and "Clean Main Burners" (page 35).
2. Visually inspect base insulation. See page 31.
3. Follow "To Place in Operation," page 31.
4. Visually inspect pilot and main burner flames. See page 32.
5. Visually inspect venting system. See page 32.
6. Check operation of low water cutoff, if used, and additional field-installed controls. Refer to manufacturer's instructions.
7. Check that boiler area is free from combustible materials, gasoline and other flammable vapors and liquids.
8. Check for and remove any obstruction to the flow of combustion or ventilation air.
9. Follow instructions on circulator to oil, if oil lubricated. Over-oiling will damage circulator. Water-lubricated circulators do not need oiling.
10. Oil blower motor. Follow instructions on blower motor. Do not use common household oils.
11. Check relief valve. Follow manufacturer's instructions on relief valve tag.
12. Check for leaks in boiler and piping. If found, repair at once.

### **DANGER**

Failure to repair leaks can cause iron corrosion, leading to section failure and leaks. Do not use petroleum-based sealing or stop-leak compounds in boiler systems. Severe damage to boiler will occur, resulting in severe personal injury, death or substantial property damage.

13. Check automatic air vent for leakage. If leaking, remove vent cap and push valve core in to wash off accumulated sediment on valve seat. Release valve, replace cap and open one turn.

## Shutdown procedure:

1. Follow "To Turn Off Gas to Appliance" instructions on boiler.
2. Do not drain system unless it will be exposed to freezing temperatures. If using antifreeze in system do not drain.

## Cleaning boiler heating surfaces:

### **WARNING**

- POSSIBLE CANCER HAZARD BY INHALATION
- CAN CAUSE RESPIRATORY, SKIN AND EYE IRRITATION

This product contains fiberglass wool and ceramic fiber materials. Airborne fibers from these materials have been listed by the State of California as a possible cause of cancer through inhalation. Apply special care when handling ceramic fiber materials (chamber lining and base insulation). Ceramic fibers can be converted to chrysothalites, a substance listed as a probable cause of cancer.

Suppliers of fiberglass wool products recommend the following precautions be taken when handling these materials.

### **Precautionary measures:**

- Avoid breathing fiberglass dust and contact with skin and eyes.
- Use NIOSH approved dust/mist respirator.
- Wear long-sleeved, loose fitting clothing, gloves and eye protection.
- Wash work clothes separately from other clothing. Rinse washer thoroughly.
- Operations such as sawing, blowing, tearout and spraying may generate airborne fiber concentration requiring additional protection.

### **First aid measures:**

- Eye contact - Flush eyes with water to remove dust. If symptoms persist, seek medical attention.
- Skin contact - Wash affected areas gently with soap and warm water after handling.

1. Follow shutdown procedure.
2. Remove venting system connection to boiler.
3. Remove top jacket panel. Turn back insulation.
4. Remove collector box/transition assembly. Clean sealant from assembly and sections.
5. Remove radiation plates hanging between sections.
6. Remove burners from base. Follow "Clean Main Burners," page 35.
7. Place newspapers in base of boiler to collect soot.
8. Clean between sections with wire flue brush.

# Suggested Minimum Service

Also refer to additional instructions packed with boiler.  
Verify proper operation after servicing.

## Cleaning boiler heating surfaces (cont'd):

9. Remove newspaper and soot. Vacuum or brush base and surrounding area.
10. Reinstall radiation plates.
11. Replace collector box/transition assembly. Seal with sealant.

**WARNING** Obtain gas-tight seal to prevent flue gas spillage and carbon monoxide emissions, resulting in severe personal injury or death.

12. Replace insulation and jacket top panel.
13. Replace main burners.

**DANGER** Burner tubes must be seated in burner rest slots with openings face up. Main burner orifices must inject down center of burner. Failure to properly seat burners will result in severe personal injury, death or substantial property damage.

14. Follow "To Place in Operation," page 31.

**NOTICE** Excessive sooting indicates improper gas combustion. If found check for proper combustion and make any necessary adjustments.

## Clean main burners:

Vacuum or brush burners to remove dust and lint.

**DANGER** Burner tubes must be seated in burner rest slots with openings face up. Main burner orifices must inject down center of burner. Failure to properly seat burners will result in severe personal injury, death or substantial property damage.

# Control System

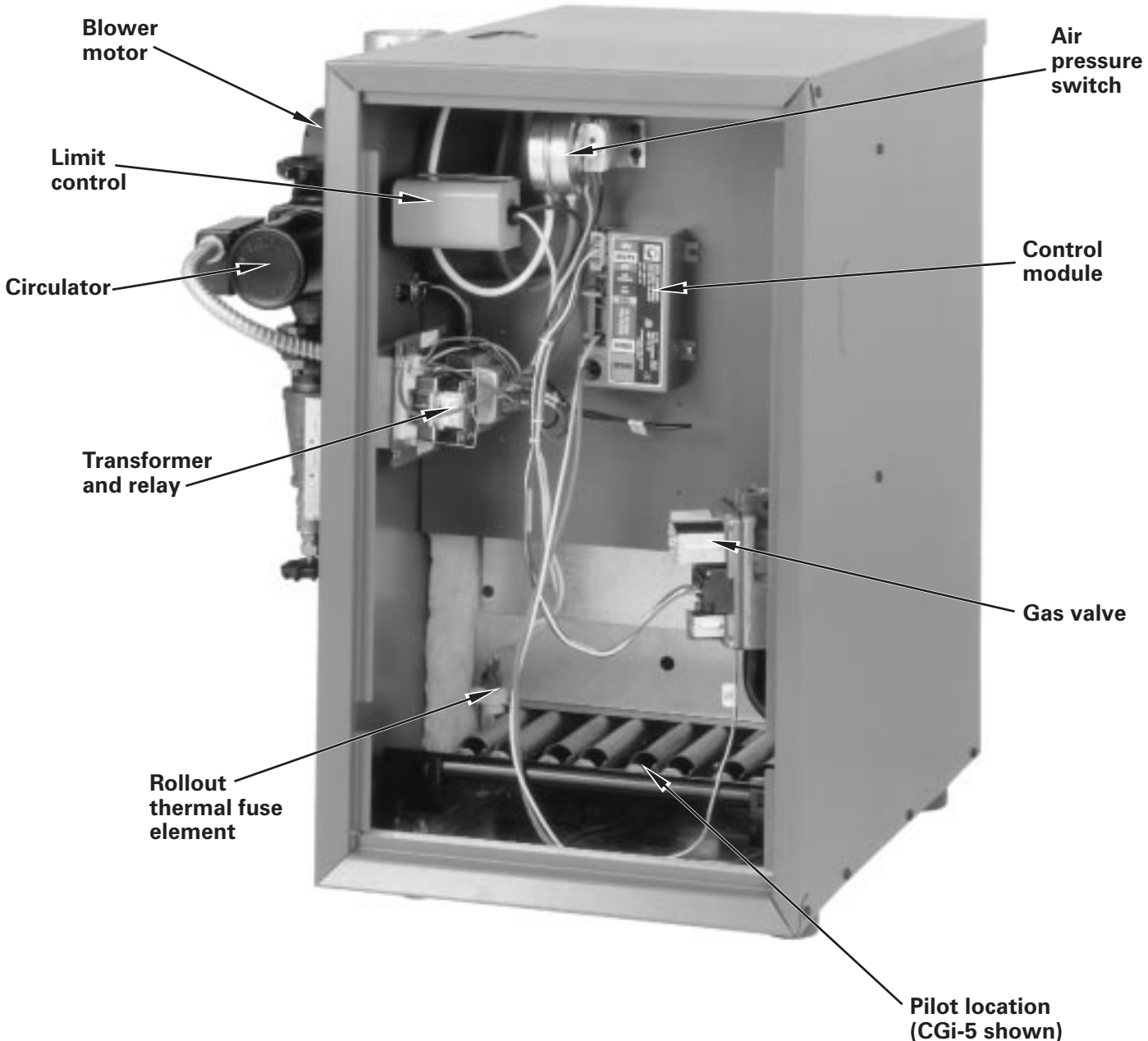



# Sequence of Operation



1. Select correct operating instruction from Table 7, according to the kind of gas valve. It should match operating instruction label on the boiler.
2. Raise room thermostat to call for heat.
3. Blower and circulator energize. After pressure switch proves proper airflow, ignition control initiates 30 second pre-purge.
4. Ignition control sparks the pilot and opens pilot valve in main gas valve.
5.
  - a. If pilot does not light within 15 seconds, pilot valve is closed and spark generator is turned off. Ignition control initiates a 5 to 6 minute wait period, while blower and circulator continue operating.
  - b. If pilot lights and ignition control senses flame current, spark generator is turned off and main valve opens.
6. During main burner operation:
  - a. Ignition control monitors pilot flame current. If signal is lost, main valve closes, spark generator activates, and sequence returns to Step #5.
  - b. If power is interrupted, control system shuts off pilot and main gas valves, and restarts at Step #1 when power is restored.
7. In the event the limit control shuts down the boiler, the blower de-energizes, causing the pressure switch circuit to open, then the ignition control closes main gas valve.
8. Thermostat is satisfied: pilot and main gas valves are closed. Blower and circulator are shut off.
9. Boiler is now in the off cycle.
10. Repeat Steps #1 through 7 several times to verify operation.
11. Return thermostat to normal setting.
12. Set thermostat heat anticipator setting indicated in notes on wiring diagram.

Gas valve	Boiler Model					
	25	3	4	5	6	7
VR8204	35	35	35	35	35	35
VR8304	—	—	—	—	—	35
WR36E	36	36	36	36	36	—
WR36C	—	—	—	—	—	37



# Operating Instructions



## Honeywell VR8204/VR8304 gas valve operating instructions

### FOR YOUR SAFETY READ BEFORE OPERATING

**WARNING:** If you do not follow these instructions exactly, a fire or explosion may result causing property damage, personal injury or loss of life.

- |  |   |
|--|---|
| <p><b>A.</b> This appliance is equipped with an ignition device which automatically lights the pilot. Do not try to light the pilot by hand.</p> <p><b>B.</b> BEFORE operating, smell all around the appliance area for gas. Be sure to smell near to the floor because some gas is heavier than air and will settle on the floor.</p> <p><b>WHAT TO DO IF YOU SMELL GAS</b></p> <ul style="list-style-type: none"> <li>• Do not try to light any appliance.</li> <li>• Do not touch any electric switch. Do not use any phone in your building.</li> <li>• Immediately call your gas supplier from a neighbor's phone. Follow the gas supplier's instructions.</li> </ul> | <ul style="list-style-type: none"> <li>• If you cannot reach your gas supplier, call the fire department.</li> </ul> <p><b>C.</b> Use only your hand to turn the gas control knob. Never use tools. If the knob will not turn by hand don't try to repair it. call a qualified service technician. Force or attempted repair may result in a fire or explosion.</p> <p><b>D.</b> Do not use this appliance if any part has been under water. Immediately call a qualified service technician to inspect the appliance and to replace any part of the control system and any gas control which has been under water.</p> |
|--|---|

### OPERATING INSTRUCTIONS

1. STOP! Read the safety information above on this label.
2. Set the thermostat to lowest setting.
3. Turn off all electric power to the appliance.
4. This appliance is equipped with an ignition device which automatically lights the pilot. Do not try to light the pilot by hand.
5. Turn gas control knob clockwise  to "OFF."
6. Wait five (5) minutes to clear out any gas. Then smell for gas, including near the floor. If you smell gas, STOP! Follow "B" in the safety information above on this label. If you don't smell gas, go to the next step.
7. Turn gas control knob counterclockwise  to "ON."
8. Turn on all electric power to the appliance.
9. Set thermostat to desired setting.
10. If the appliance will not operate, follow the instructions "To Turn Off Gas To Appliance" and call your service technician or gas supplier.
11. Replace front panel.

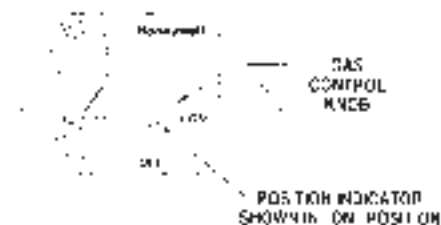

### TO TURN OFF GAS TO APPLIANCE

- |  |   |
|--|---|
| <ol style="list-style-type: none"> <li>1. Set the thermostat to lowest setting.</li> <li>2. Turn off all electric power to the appliance if service is to be performed.</li> </ol> | <ol style="list-style-type: none"> <li>3. Turn gas control knob clockwise  to "OFF." Do not force.</li> <li>4. Replace front panel.</li> </ol> |
|--|---|

550-223-237 (0697)

# Operating Instructions



## White-Rodgers 36E gas valve operating instructions

### FOR YOUR SAFETY READ BEFORE OPERATING

**WARNING:** If you do not follow these instructions exactly, a fire or explosion may result causing property damage, personal injury or loss of life.

- A. This appliance is equipped with an ignition device which automatically lights the pilot. Do **not** try to light the pilot by hand.
- B. **BEFORE** operating, smell all around the appliance area for gas. Be sure to smell **near** to the floor because some gas is heavier than air and will settle on the floor.  
**WHAT TO DO IF YOU SMELL GAS**  
 • Do not try to light any appliance.  
 • Do not touch any electric switch; do not use any phone in your building.  
 • Immediately call your gas supplier from a neighbor's phone. Follow the gas supplier's instructions.  
 • If you cannot reach your gas supplier, call the fire department.
- C. Use only your hand to turn the gas control knob. Never use tools. If the knob will not turn by hand, don't try to repair it. Call a qualified service technician. Force or attempted repair may result in a fire or explosion.
- D. Do not use this appliance if any part has been under water. Immediately call a qualified service technician to inspect the appliance and to replace any part of the control system and any gas control which has been under water.

### OPERATING INSTRUCTIONS

1. **STOP!** Read the safety information above on this label.
2. Set the thermostat to lowest setting.
3. Turn off all electric power to the appliance.
4. This appliance is equipped with an ignition device which automatically lights the pilot. Do not try to light the pilot by hand.
5. Turn gas control knob clockwise  to "OFF."
6. Wait five (5) minutes to clear out any gas. Then smell for gas, including near the floor. If you smell gas, **STOP!** Follow "B" in the safety information above on this label. If you don't smell gas, go to the next step.
7. Turn gas control knob counterclockwise  to "ON."
8. Turn on all electric power to the appliance.
9. Set thermostat to desired setting.
10. If the appliance will not operate, follow the instructions "To Turn Off Gas To Appliance" and call your service technician or gas supplier.
11. Replace front panel.

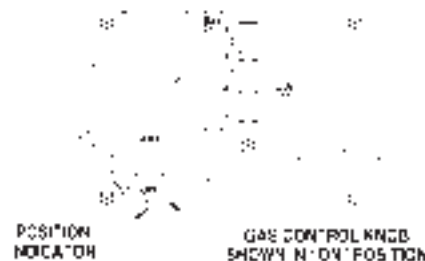

### TO TURN OFF GAS TO APPLIANCE

1. Set the thermostat to lowest setting.
2. Turn off all electric power to the appliance if service is to be performed.
3. Turn gas control knob clockwise  to "OFF." Do not force.
4. Replace front panel.

550-223-235 (0697)



## White-Rodgers 36C gas valve operating instructions

### FOR YOUR SAFETY READ BEFORE OPERATING

**WARNING:** If you do not follow these instructions exactly, a fire or explosion may result causing property damage, personal injury or loss of life.

- |   |   |
|---|---|
| <p>A. This appliance is equipped with an ignition device which automatically lights the pilot. Do not try to light the pilot by hand.</p> <p>B. <b>BEFORE</b> operating, smell all around the appliance area for gas. Be sure to smell next to the floor because some gas is heavier than air and will settle on the floor.</p> <p><b>WHAT TO DO IF YOU SMELL GAS</b></p> <ul style="list-style-type: none"> <li>• Do not try to light any appliance.</li> <li>• Do not touch any electric switch; do not use any phone in your building.</li> <li>• Immediately call your gas supplier from a neighbor's phone. Follow the gas supplier's instructions.</li> </ul> | <ul style="list-style-type: none"> <li>• If you cannot reach your gas supplier, call the fire department.</li> </ul> <p>C Use only your hand to turn the gas control knob. Never use tools. If the knob will not turn by hand, don't try to repair it. call a qualified service technician. Force or attempted repair may result in a fire or explosion.</p> <p>D. Do not use this appliance if any part has been under water. Immediately call a qualified service technician to inspect the appliance and to replace any part of the control system and any gas control which has been under water.</p> |
|---|---|

### OPERATING INSTRUCTIONS

1. **STOP!** Read the safety information above on this label.
  2. Set the thermostat to lowest setting.
  3. Turn off all electric power to the appliance.
  4. This appliance is equipped with an ignition device which automatically lights the pilot. Do not try to light the pilot by hand.
  5. Depress gas control knob slightly and turn clockwise  to "OFF."
- NOTE: Knob cannot be turned to "OFF" unless knob is depressed slightly. Do not force.
6. Wait five (5) minutes to clear out any gas. Then smell for gas, including near the floor. If you smell gas **STOP!** Follow "B" in the safety information above on this label. If you don't smell gas, go to the next step.
  7. Turn gas control knob counterclockwise  to "ON."
  8. Turn on all electric power to the appliance.
  9. Set thermostat to desired setting.
  10. If the appliance will not operate, follow the instructions "To Turn Off Gas To Appliance" and call your service technician or gas supplier.
  11. Replace front panel.

POSITION INDICATOR SHOWN IN ON POSITION



### TO TURN OFF GAS TO APPLIANCE

- |  |  |
|--|--|
| <ol style="list-style-type: none"> <li>1. Set the thermostat to lowest setting.</li> <li>2. Turn off all electric power to the appliance if service is to be performed.</li> </ol> | <ol style="list-style-type: none"> <li>3. Depress gas control knob slightly and turn clockwise  to "OFF." Do not force.</li> <li>4. Replace front panel.</li> </ol> |
|--|--|

550-223-236 (0697)

# Troubleshooting



## Troubleshooting procedure:

**WARNING** Label all wires prior to disconnection when servicing controls. Wiring errors can cause improper and dangerous operation.

**WARNING** Never jumper (bypass) rollout thermal fuse element or any other device except for momentary testing as outlined in Troubleshooting Charts. A fire or explosion can result, causing severe personal injury, death or substantial property damage.

**DANGER** Burner access panel must be in position during boiler operation to prevent momentary flame rollout on ignition of main flame. Failure to do so will result in severe personal injury, death or substantial property damage.

1. Before troubleshooting:
  - a. Have a voltmeter that can check 120VAC and 24VAC, a microammeter with minimum scale range of 0-25, and a continuity checker.
  - b. Have an inclined manometer with 0-2" W.C. range.
  - c. Check for 120VAC (min. 102VAC to max. 132VAC) to boiler.
  - d. Make sure thermostat is calling for heat and contacts (including appropriate zone controls) are closed. Check for 24VAC between thermostat wire nuts and ground.
2. Check that air pressure switch hoses are correctly and securely installed and are not damaged.
3. Check gas pressures:
  - a. With boiler off: 13" W.C. maximum natural or propane gas pressure upstream of gas valve.
  - b. With boiler on:
    - 5" W.C. minimum natural gas pressure or 11" W.C. propane gas pressure upstream of gas valve.
    - 3-1/2" W.C. minimum natural gas pressure or 10" W.C. propane gas pressure downstream tapping on gas valve. Can be adjusted by regulator on gas valve.

## Checking air pressure switch:

**NOTICE** Make sure boiler water temperature is 100°F or cooler before starting procedure to obtain appropriate readings.

1. Remove white hose from silver hose barb on left side of pressure switch as you face the boiler. See Figure 30.
2. Install a tee into white hose. Run another piece of hose from the tee to the pressure switch.
3. Attach third leg of tee to suction side of manometer.
4. Remove red hose from red hose barb on right side of pressure switch.
5. Install a tee into red hose. Run another piece of hose from the tee to the right side of the pressure switch.
6. Attach third leg of tee to pressure side of manometer.
7. Close manual main shutoff gas valve and set thermostat to call for heat. Blower will run but pilot and main burners will not ignite.
8. Check for 24VAC between normally open terminal on pressure switch and terminal C on transformer.
9. If manometer reading is above the set point (see Table 8) of the switch, but if there are not 24VAC across N.O. terminal on pressure switch and terminal C, replace pressure switch.
10. If reading is lower than set point, look for the following causes:
  - a. Blockage in hoses.
  - b. Obstruction in blower housing outlet.
  - c. Loose blower wheel on motor shaft.
  - d. Blower motor not at correct rpm.
  - e. Blower back plate not sealed properly.
  - f. Blockage in block assembly.
  - g. Blockage in flue pipe or termination.
  - h. Incorrect pressure switch.
11. When pressure reading is correct and pressure switch is operating properly, remove tees and reinstall:
  - a. White hose to silver hose barb on left side of pressure switch.
  - b. Red hose to red hose barb on right side of pressure switch.

# Troubleshooting

Boiler Model	Inches W.C.
CGi - 25	1.18"
CGi - 3	1.18"
CGi - 4	1.18"
CGi - 5	0.96"
CGi - 6	0.75"
CGi - 7	0.59"

\* For elevations above 2000 feet, contact your local Weil-McLain sales office for details.

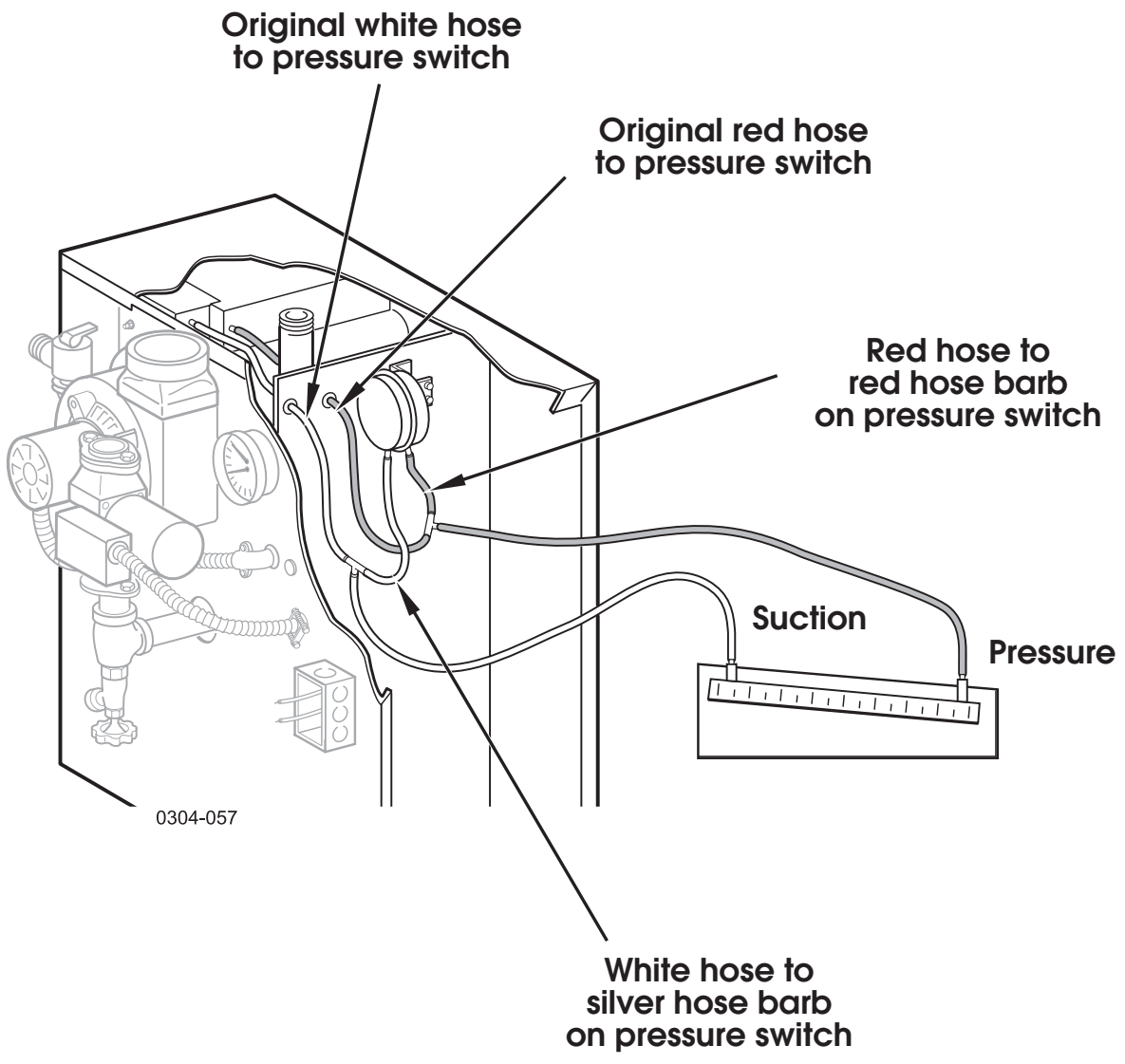

**CHECKING AIR PRESSURE SWITCH**  
**FIGURE 30**

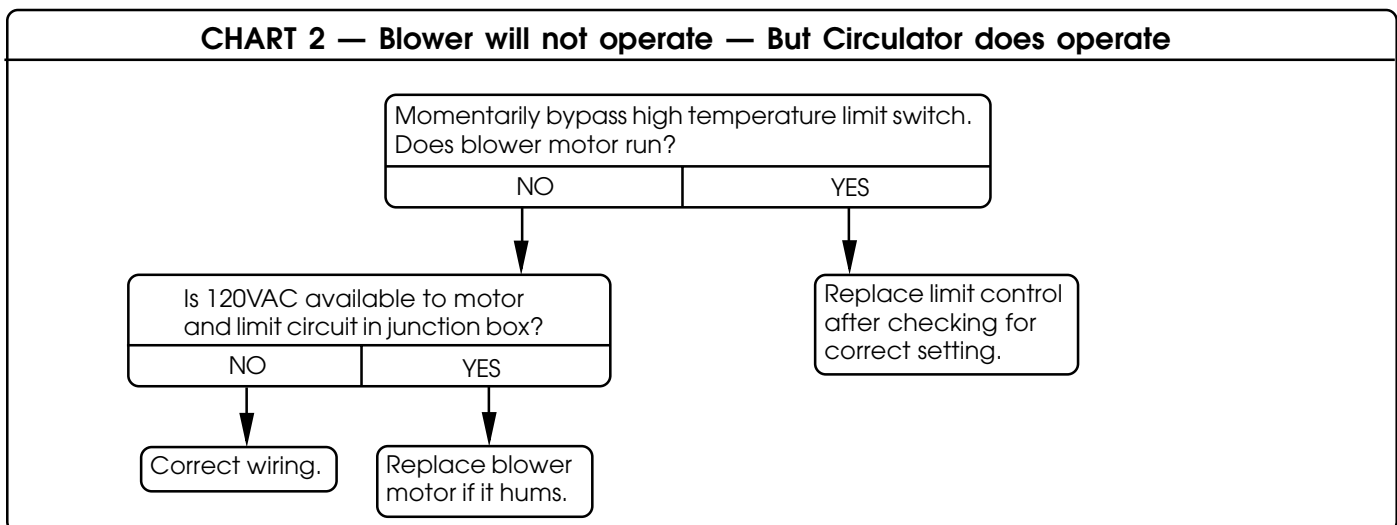
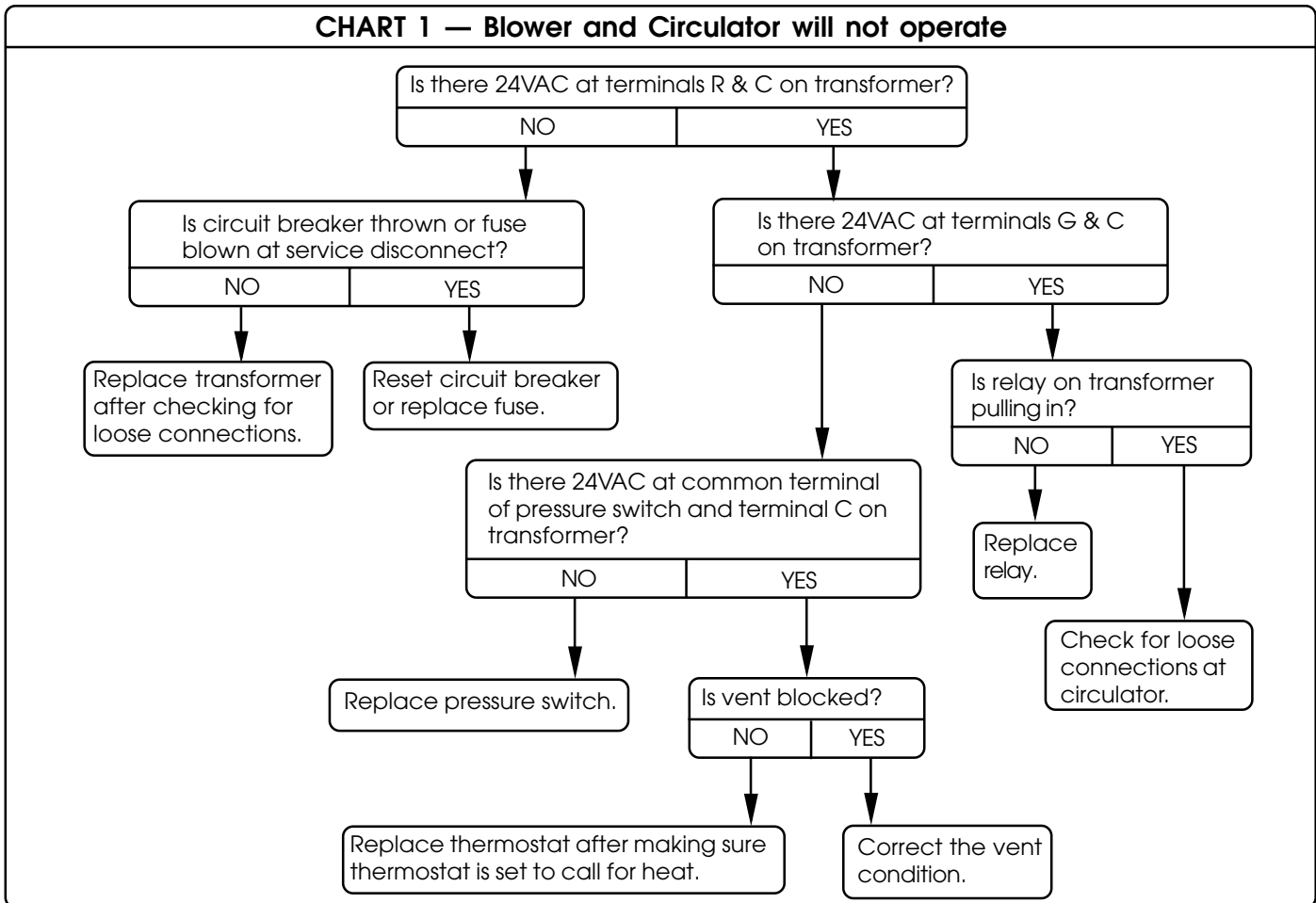

# Troubleshooting

**CHART 3 — No spark — System does not operate**

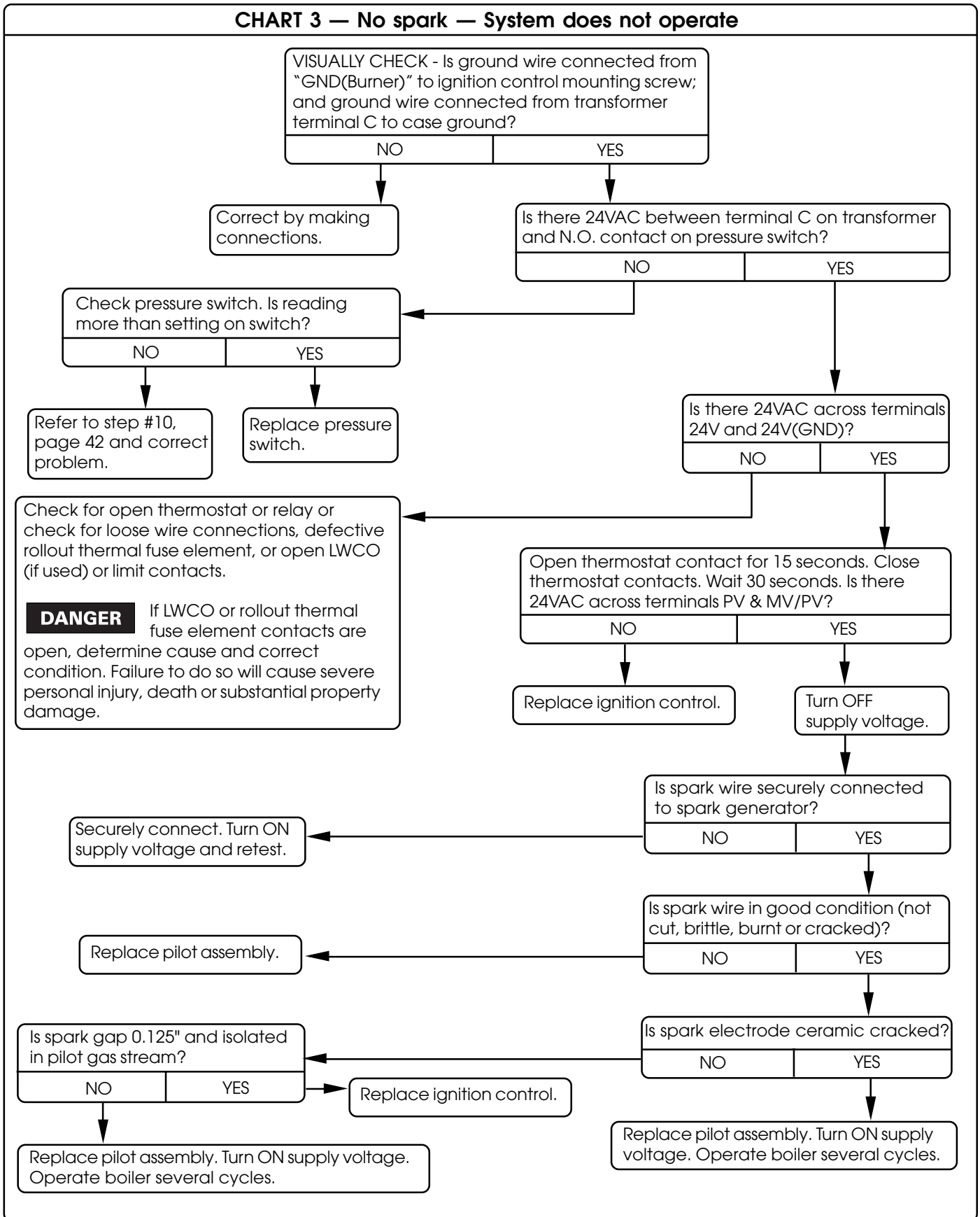

### To check ignition system ground for CHART 5, Page 47

Pilot assembly and ignition control must share common ground with main burner. Nuisance shutdowns are often caused by poor or erratic ground.

- Check for good metal-to-metal contact between pilot burner bracket and main burner, and between main burner and burner rest.
- Check ground lead from GND (BURNER) terminal on the ignition control to ignition control mounting screw, and from terminal C on transformer to the transformer case ground. Make sure connections are clean and tight. If wire is damaged or deteriorated, replace with No. 18 ga. moisture-resistant, thermoplastic insulated wire with 105°C minimum rating.

### CHART 4 — Spark is present — Pilot will not light

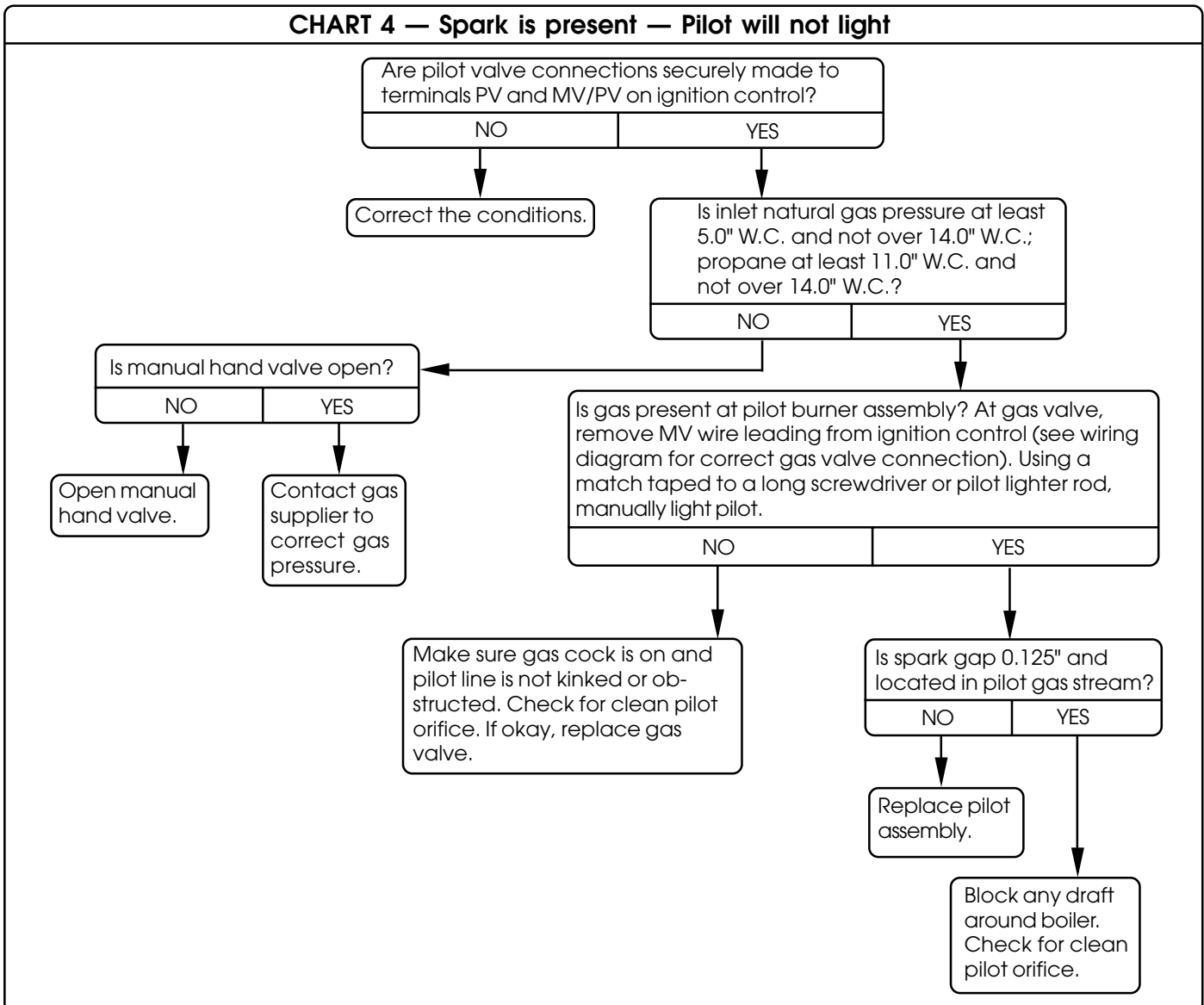

# Troubleshooting

**CHART 5 — Pilot lights — Main valve will not come on**

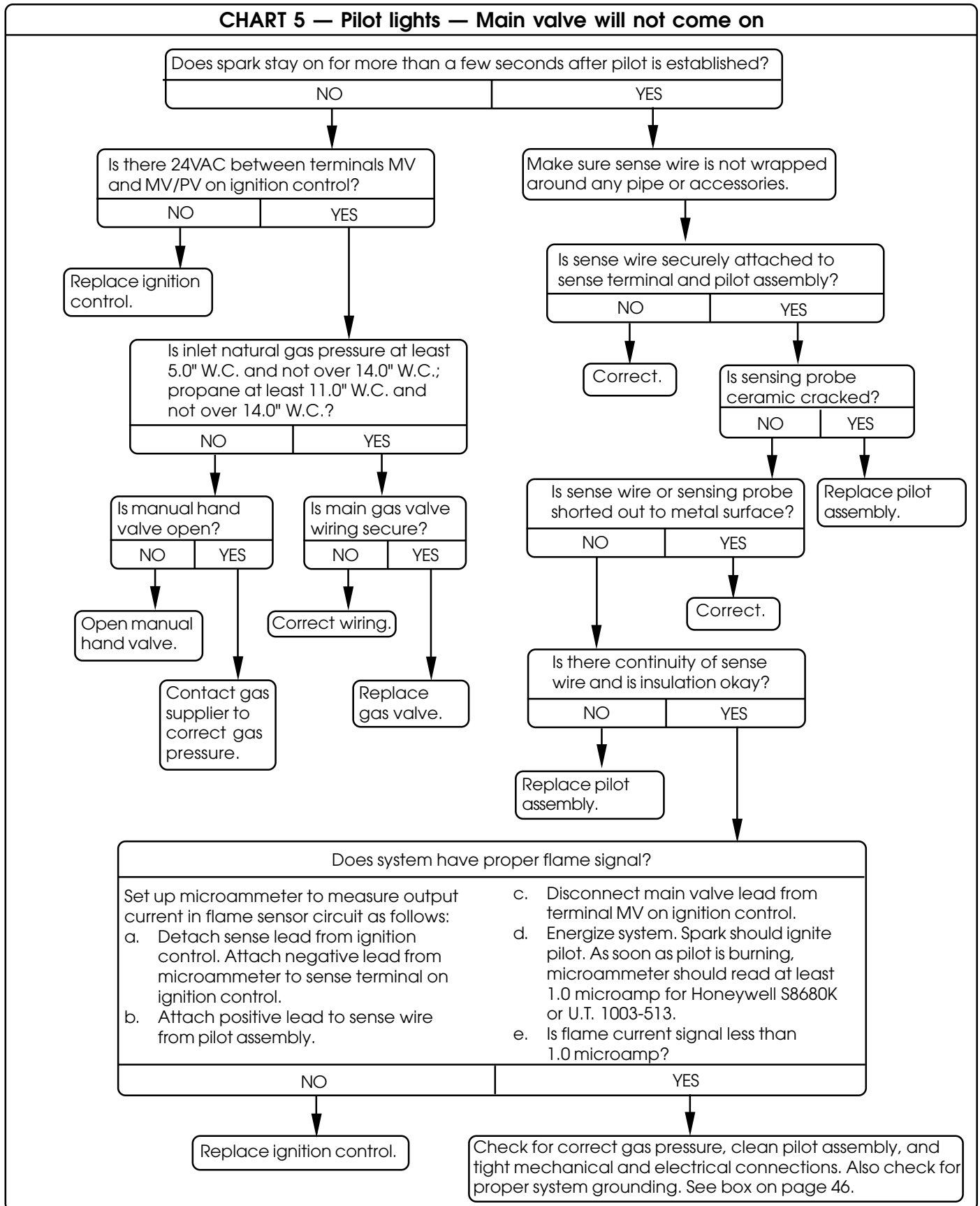

# Parts List



Section Assembly .....	49
Base Assembly .....	50
Jacket Assembly .....	51
Boiler Trim Assembly .....	52
Gas Control Assembly .....	53

Replacement parts must be purchased through a local Weil-McLain Distributor. When ordering, specify boiler model and size and include description and part number of replacement part. Results from using modified or other-manufactured parts will not be covered by warranty and may damage boiler or impair operation.

Weil-McLain Part Numbers are found in Weil-McLain Boilers and Controls Repair Parts Lists.

# Parts List

## CGi Section Assembly

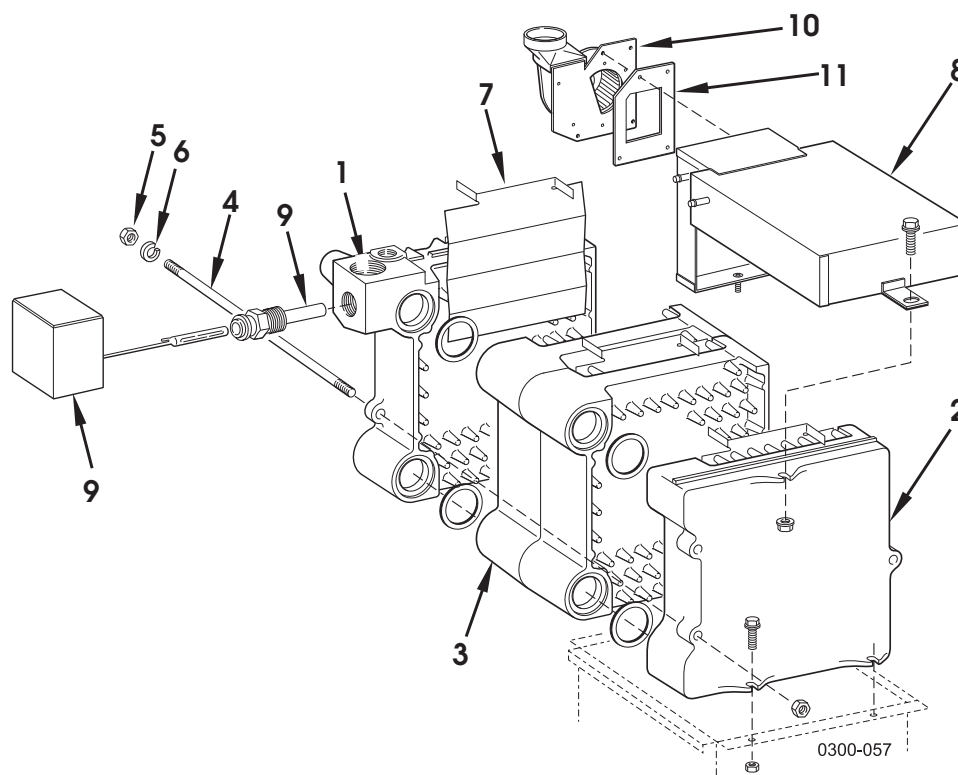

FIG. NO.	DESCRIPTION	WEIL-MCLAIN PART NUMBER
1	Left Hand End Section, 51124	311-103-815
2	Right Hand End Section, 51128	311-103-821
3	Intermediate Section, 51125	311-103-818
N.S.	Replacement Section Assembly: CGi-25 & 3 Replacement Section Assembly: CGi-4 Replacement Section Assembly: CGi-5 Replacement Section Assembly: CGi-6 Replacement Section Assembly: CGi-7	321-114-315 321-114-316 321-114-317 321-114-318 321-114-319
N.S.	Section Replacement Kit (includes: Seals and Sealant for 1 joint)	381-354-527
4	7/16 Tie Rod w/o Nut (3 per Boiler): CGi-25 & 3 7/16 Tie Rod w/o Nut (3 per Boiler): CGi-4 7/16 Tie Rod w/o Nut (3 per Boiler): CGi-5 7/16 Tie Rod w/o Nut (3 per Boiler): CGi-6 7/16 Tie Rod w/o Nut (3 per Boiler): CGi-7	560-234-500 560-234-501 560-234-502 560-234-503 560-234-504
5	7/16 Nut (2 per Tie Rod)	561-928-235
6	7/16 Washer (1 per Tie Rod)	562-248-684
7	Radiation Plate (1 per Joint)	460-003-700
8	Collector Hood and Transition Assembly: CGi-25 Collector Hood and Transition Assembly: CGi-3 Collector Hood and Transition Assembly: CGi-4 Collector Hood and Transition Assembly: CGi-5 Collector Hood and Transition Assembly: CGi-6 Collector Hood and Transition Assembly: CGi-7	381-354-581 381-354-582 381-354-583 381-354-584 381-354-585 381-354-586
9	High Limit, 30 differential, w/well, case, cover and screw - HW L4080B1386 or WR 11B83-17	510-312-254
10	Inducer Fan Assembly Kit (includes Inducer Fan Assembly, Gasket, and Nuts)	381-354-580
11	Gasket for Inducer	590-317-627

# Parts List

## CGi Base Assembly

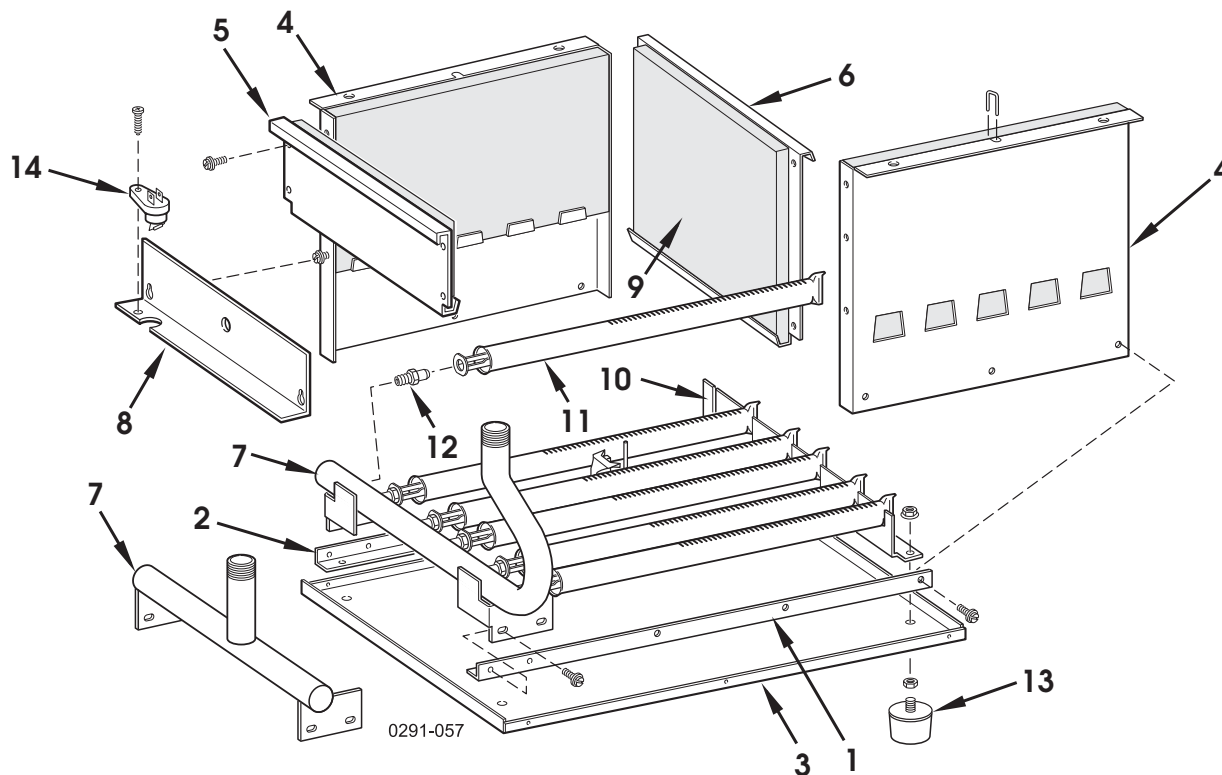

FIG. NO.	DESCRIPTION	WEIL-MCLAIN PART NUMBER
1	Base Pan Angle - Right Hand	450-030-474
2	Base Pan Angle - Left Hand	450-030-475
3	Base Pan: CGi-25 & 3	450-003-730
	Base Pan: CGi-4	450-003-731
	Base Pan: CGi-5	450-003-732
	Base Pan: CGi-6	450-003-733
	Base Pan: CGi-7	450-003-734
4	Base Side Panel	460-003-710
5	Base Front Cross Tie: CGi-25 & 3	460-003-777
	Base Front Cross Tie: CGi-4	460-003-778
	Base Front Cross Tie: CGi-5	460-003-779
	Base Front Cross Tie: CGi-6	460-003-780
	Base Front Cross Tie: CGi-7	460-003-781
6	Base Back Cross Tie: CGi-25 & 3	460-003-701
	Base Back Cross Tie: CGi-4	460-003-702
	Base Back Cross Tie: CGi-5	460-003-703
	Base Back Cross Tie: CGi-6	460-003-704
	Base Back Cross Tie: CGi-7	460-003-705
7	Manifold: CGi-25	591-126-615
	Manifold: CGi-3	591-126-616
	Manifold: CGi-4	591-126-617
	Manifold: CGi-5	591-126-618
	Manifold: CGi-6	591-126-619
	Manifold: CGi-7	591-126-556

FIG. NO.	DESCRIPTION	WEIL-MCLAIN PART NUMBER
8	Access Panel: CGi-25 & 3	460-003-741
	Access Panel: CGi-4	460-003-742
	Access Panel: CGi-5	460-003-743
	Access Panel: CGi-6	460-003-744
	Access Panel: CGi-7	460-003-745
9	Base Insulation Set: CGi-25-5	381-354-518
	Base Insulation Set: CGi-6-7	381-354-519
10	Burner Rest: CGi-25	450-003-742
	Burner Rest: CGi-3	450-003-736
	Burner Rest: CGi-4	450-003-737
	Burner Rest: CGi-5	450-003-738
	Burner Rest: CGi-6	450-003-739
	Burner Rest: CGi-7	450-003-740
11	Burner, Regular	512-200-060
12	Main Burner Orifice, 2.0mm, Natural	560-528-997
	Main Burner Orifice, 1.3mm, Propane	560-528-998
13	Boiler Leg Kit	550-320-219
14	Rollout Thermal Fuse Element, Microtemp G4AM0600228C or Elmwood Sensors RD226-001	512-050-230

# Parts List

## CGi Jacket Assembly

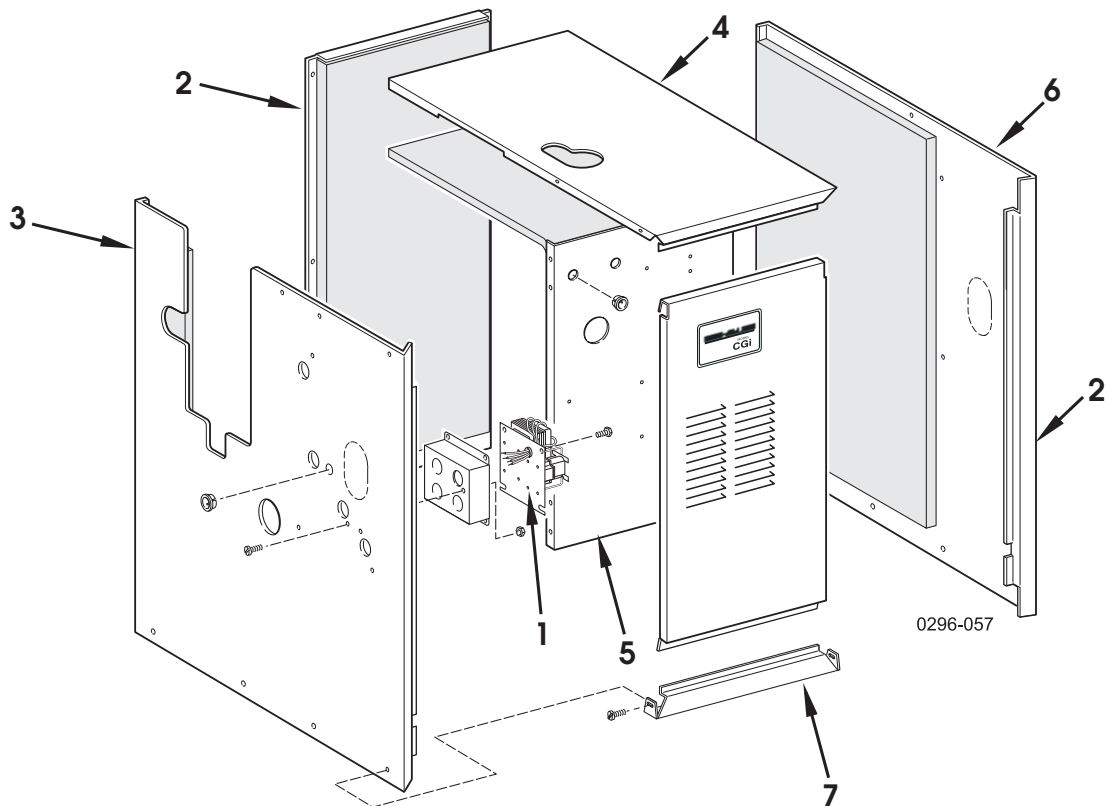
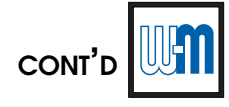

FIG. NO.	DESCRIPTION	WEIL-MCLAIN PART NUMBER
1	Transformer/Relay Assembly - HW R825D1000 or WR 631-9001	510-312-167
	Transformer (Relay not included) - HW R8285K1004 or WR S84A-85	510-312-166
	Relay - HW R8222U1006 or WR 91-112006-11000	510-350-223
2	Jacket Panels, Rear & Door: CGi-25 & 3	431-223-160
	Jacket Panels, Rear & Door: CGi-4	431-223-161
	Jacket Panels, Rear & Door: CGi-5	431-223-162
	Jacket Panels, Rear & Door: CGi-6	431-223-163
	Jacket Panels, Rear & Door: CGi-7	431-223-164
3	Jacket Panel, Left Side	431-223-240
4	Jacket Panel, Top: CGi-25 & 3	431-223-245
	Jacket Panel, Top: CGi-4	431-223-246
	Jacket Panel, Top: CGi-5	431-223-247
	Jacket Panel, Top: CGi-6	431-223-248
	Jacket Panel, Top: CGi-7	431-223-249
5	Jacket Panel, Interior: CGi-25 & 3	431-223-270
	Jacket Panel, Interior: CGi-4	431-223-271
	Jacket Panel, Interior: CGi-5	431-223-272
	Jacket Panel, Interior: CGi-6	431-223-273
	Jacket Panel, Interior: CGi-7	431-223-274
6	Jacket Panel, Right Side	421-208-160
7	Jacket Cross Tie, Bottom Front: CGi-25 & 3	431-214-124
	Jacket Cross Tie, Bottom Front: CGi-4	431-214-125
	Jacket Cross Tie, Bottom Front: CGi-5	431-214-126
	Jacket Cross Tie, Bottom Front: CGi-6	431-214-127
	Jacket Cross Tie, Bottom Front: CGi-7	431-214-128

# Parts List



## CGi Boiler Trim Assembly

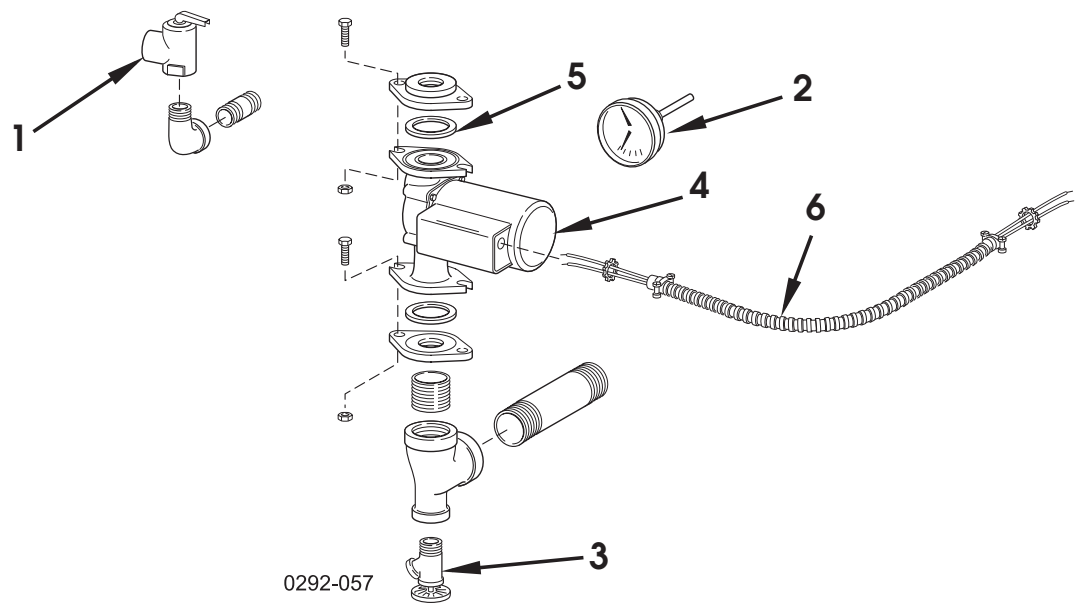

FIG. NO.	DESCRIPTION	MANUFACTURER	MANUFACTURER'S PART NUMBER	WEIL-MCLAIN PART NUMBER	CGi SERIES 1 BOILER SIZE						
					25	3	4	5	6	7	
1	ASME Pressure Relief Valve, 30 PSIG, 3/4 male inlet	Conbraco	10-407-05	511-546-921	1	1	1	1	1	1	
	ASME Pressure Relief Valve, 30 PSIG, 3/4 male inlet	Watts	M335	511-546-921	1	1	1	1	1	1	
	ASME Pressure Relief Valve, 30 PSIG, 3/4 female inlet	Conbraco	10-408-05	511-546-924	1	1	1	1	1	1	
	ASME Pressure Relief Valve, 30 PSIG, 3/4 female inlet	Watts	335	511-546-924	1	1	1	1	1	1	
2	Combination Pressure-Temperature Gauge, 2-1/2", short shank	Ametek	PTA-1088	510-218-099	1	1	1	1	1	1	
	Combination Pressure-Temperature Gauge, short shank	ENFM	4104	510-218-099	1	1	1	1	1	1	
3	Drain Valve, 3/4	Conbraco	31-606-01	511-210-423	1	1	1	1	1	1	
	Drain Valve, 3/4	Hammond Valve	710	511-246-392	1	1	1	1	1	1	
	Drain Valve, 3/4	Matco-Norca	205F04	511-246-392	1	1	1	1	1	1	
	Drain Valve, 3/4	Watts	BD-2C	511-246-392	1	1	1	1	1	1	
4	Circulator	Bell & Gossett	NRF-22-103253	511-405-118	1	1	1	1	1	1	
	Circulator	Bell & Gossett	100	511-405-115	1	1	1	1	1	1	
	Circulator	Grundfos	UP15-42FR-TB4	511-405-126	1	1	1	1	1	1	
	Circulator	Taco	007	511-405-113	1	1	1	1	1	1	
	Circulator	Taco	110	511-405-116	1	1	1	1	1	1	
5	Circulator Gasket, Universal	Weil-McLain	-	590-317-535	2	2	2	2	2	2	
N.S.	Circulator Hardware Kit, 3/4 (see note below)	Weil-McLain	-	381-354-530	1	-	-	-	-	-	
N.S.	Circulator Hardware Kit, 1" (see note below)	Weil-McLain	-	381-354-525	-	1	1	1	-	-	
N.S.	Circulator Hardware Kit, 1-1/4 (see note below)	Weil-McLain	-	381-354-526	-	1	1	1	1	1	
6	Wiring Harness for Circulator ( B&G UP15, Grundfos NRF-22 and Taco 007)			591-319-793	1	1	1	1	1	1	
	Wiring Harness for Circulator (B&G 100, Taco 110)			591-319-842	1	1	1	1	1	1	
Circulator Hardware Kit contains 1 flange, 1 gasket, 2 nuts and 2 screws.											
Limit control See page 49.											

# Parts List

## CGi Gas Control Assembly

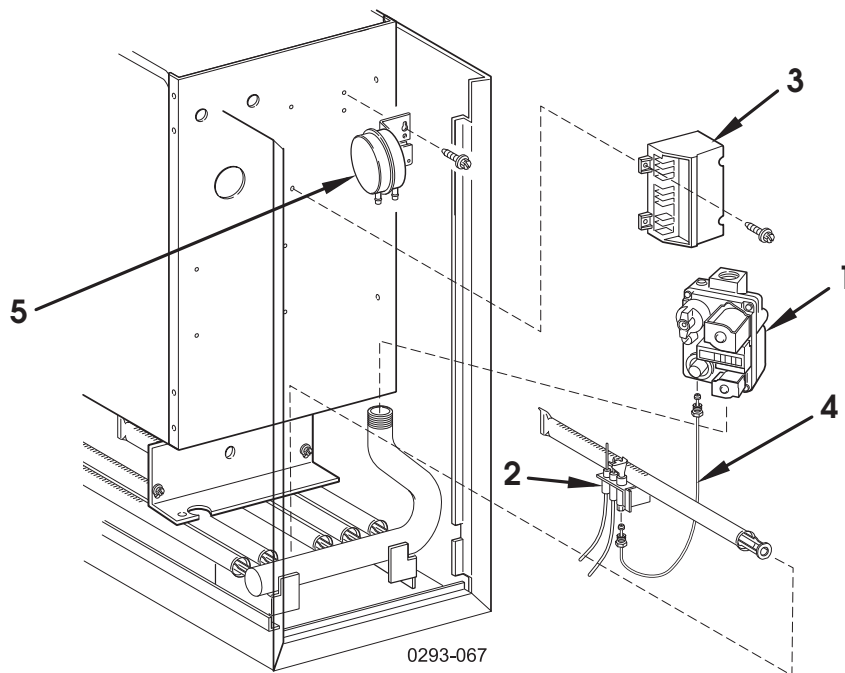

FIG. NO.	DESCRIPTION	MANUFACTURER	MANUFACTURER'S PART NUMBER	WEIL-MCLAIN PART NUMBER	CGi SERIES 1 BOILER SIZE						
					25	3	4	5	6	7	
<b>GAS COMPONENTS FOR NATURAL GAS ONLY</b>											
1N	Gas Valve, 1/2 x 1/2 , Nat.	Honeywell	VR8204A2001	511-044-381	1	1	1	1	1	1	
1N	Gas Valve, 1/2 x 1/2 , Nat.	White-Rodgers	36E36-266	511-044-381	1	1	1	1	1	1	
1N	Gas Valve, 3/4 x 3/4 , Nat.	Honeywell	VR8304M4002	511-044-353						1	
1N	Gas Valve, 3/4 x 3/4 , Nat.	White-Rodgers	36C68-478	511-044-353						1	
2N	Pilot Assembly Kit, w/orifice and burner with pilot bracket, Nat.	Weil-McLain	-	510-811-221	1	1	1	1	1	1	
<b>GAS COMPONENTS FOR PROPANE GAS ONLY</b>											
1P	Gas Valve, 1/2 x 1/2 , LP	Honeywell	VR8204M2701	511-044-354	1	1	1	1	1	1	
1P	Gas Valve, 1/2 x 1/2 , LP	White-Rodgers	36E36-291	511-044-354	1	1	1	1	1	1	
1P	Gas Valve, 3/4 x 3/4 , LP	Honeywell	VR8304M4010	511-044-355						1	
1P	Gas Valve, 3/4 x 3/4 , LP	White-Rodgers	36C68-479	511-044-355						1	
2P	Pilot Assembly Kit, w/orifice and burner with slanted pilot bracket, LP	Weil-McLain	-	510-811-222	1	1	1	1	1	1	
<b>GAS CONTROL COMPONENTS FOR NATURAL AND PROPANE GAS</b>											
3	Ignition Control module	Honeywell	S8680K-2000	511-330-099	1	1	1	1	1	1	
3	Ignition Control module	United Technologies	1003-513	511-330-099	1	1	1	1	1	1	
N.S.	Wiring Harness	Weil-McLain	-	591-319-795	1	1	1	1	1	1	
4	Pilot Tubing, .12 O.D., aluminum	Weil-McLain	-	560-742-860	1	1	1	1	1	1	
5	Pressure Differential Switch, 1.18 W.C.	Tri-Delta	FS6206A-2417	511-624-450	1	1	1	-	-	-	
	Pressure Differential Switch, .96 W.C.	Tri-Delta	FS6206A-2416	511-624-451	-	-	-	1	-	-	
	Pressure Differential Switch, .75 W.C.	Tri-Delta	FS6206A-2415	511-624-452	-	-	-	-	1	-	
	Pressure Differential Switch, .59 W.C.	Tri-Delta	FS6206A-2414	511-624-453	-	-	-	-	-	1	
N.S.	Pressure Differential Switch Tubing, .12 I.D., red, pressure switch to collector hood	Lydall	-	590-317-650	1	1	1	1	1	1	
N.S.	Pressure Differential Switch Tubing, .12 I.D., white, pressure switch to transition	Lydall	-	590-317-651	1	1	1	1	1	1	

# Ratings



DOE



▲ BOILER MODEL	A.G.A. (UNITED STATES)		C.G.A. (CANADA)				** NET I=B=R RATINGS BTU/HR.	BOILER WATER CONTENTS GAL.	D.O.E. SEASONAL EFFICIENCY (A.F.U.E.)	+ BREECHING SIZE
	INPUT BTU/HR.	* D.O.E. HEATING CAPACITY	0-2000 FT		2000-4500 FT.					
			INPUT BTU/HR.	OUTPUT BTU/HR.	INPUT BTU/HR.	OUTPUT BTU/HR.				
<b>CGi-25</b>	50,000	42,000	50,000	42,000	45,000	37,000	37,000	1.5	83.0	4"
<b>CGi-3</b>	67,000	56,000	67,000	56,000	60,000	50,000	49,000	1.5	83.3	4"
<b>CGi-4</b>	100,000	84,000	100,000	84,000	90,000	75,000	73,000	2.1	83.0	5"
<b>CGi-5</b>	133,000	111,000	133,000	111,000	119,000	99,000	97,000	2.7	82.7	5"
<b>CGi-6</b>	167,000	139,000	167,000	139,000	150,000	125,000	121,000	3.3	82.4	5"
<b>CGi-7</b>	200,000	166,000	200,000	166,000	180,000	148,000	144,000	3.8	82.1	5"
<p>▲ Add PIN for natural gas boiler; PIL for propane gas.</p> <p>* Based upon standard test procedures prescribed by the United States Department of Energy.</p> <p>** Net I=B=R ratings are based on net installed radiation of sufficient quantity for the requirements of the building and nothing need be added for normal piping and pick-up. Ratings are based on a piping and pick-up allowance of 1.15. An additional allowance should be made for unusual piping and pick-up loads.</p> <p>+ Refer to National Fuel Gas Code, ANSI Z223.1-latest edition, or in Canada, CAN/CSA B149.1 or B149.2 Installation Code for chimney sizing and vent connector lengths. CGI boiler may also be vented directly outside using 3" vent pipe as specified in CGI Boiler Manual.</p>										
<p><b>NOTES:</b></p> <p>1) CGi boilers for residential radiant panel systems, converted gravity heating systems, or other low-water temperature applications should be installed with balancing valves and bypass piping equal to the supply and return size to avoid excessive flue gas condensation due to lower operating water temperatures. For alternate piping, contact your Weil-McLain sales office.</p> <p>2) A.G.A. design certified for installation on combustible flooring. Tested for 50 psi working pressure.</p>										

# Dimensions

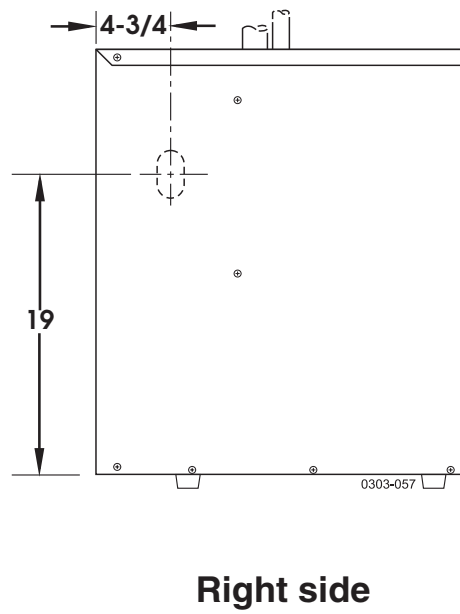
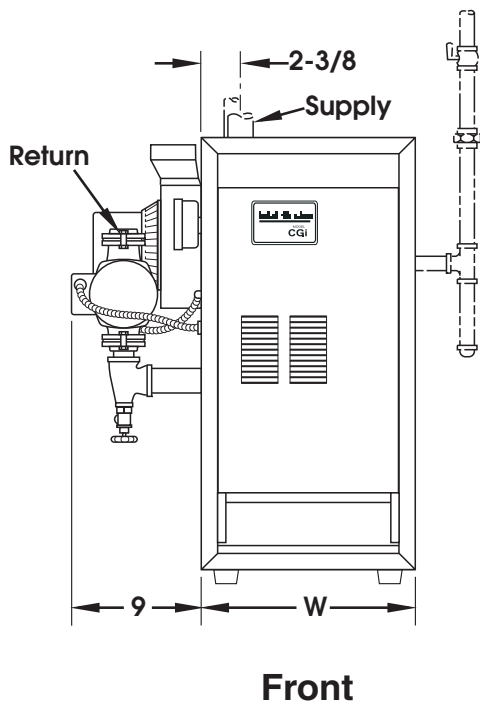
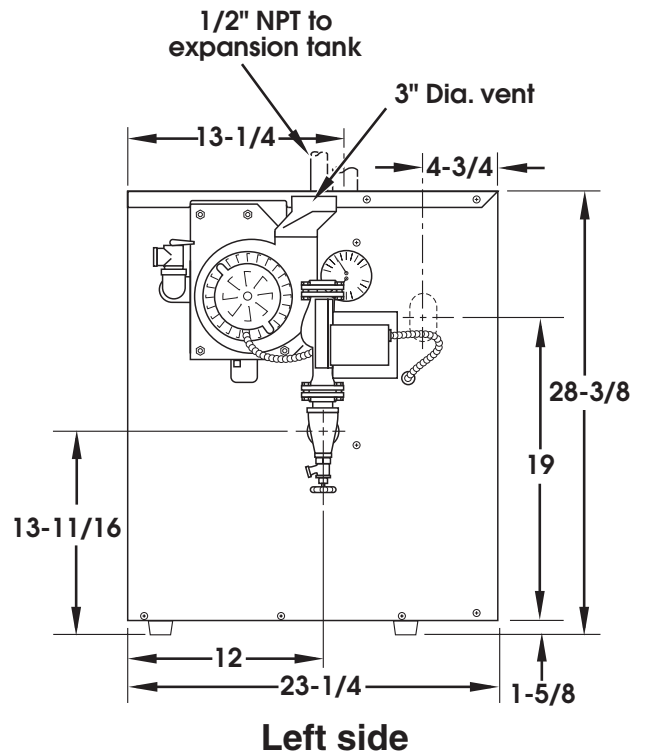
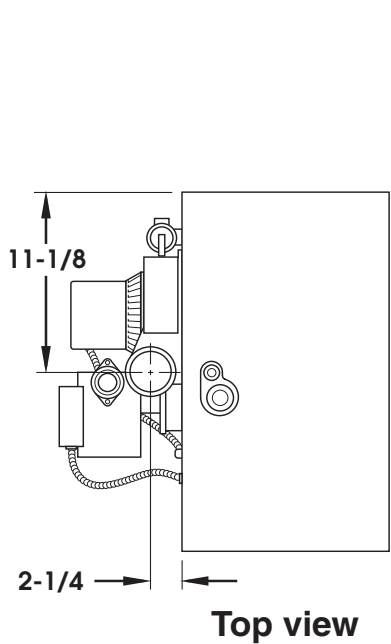

BOILER MODEL	SUPPLY OUTLET PIPE SIZE	RETURN INLET PIPE SIZE	GAS CONNECTION PIPE SIZE (ALL GASES)	GAS MANIFOLD PIPE SIZE (ALL GASES)	"W" DIMENSION
CGi-25	1 1/4"	3/4"	1/2"	1/2"	10"
CGi-3	1 1/4"	1"	1/2"	1/2"	10"
CGi-4	1 1/4"	1"	1/2"	1/2"	13"
CGi-5	1 1/4"	1"	1/2"	1/2"	16"
CGi-6	1 1/4"	1 1/4"	1/2"	1/2"	19"
CGi-7	1 1/4"	1 1/4"	3/4"	3/4"	2"