



# AHE SERIES 4

Direct Vent Wall-Mounted Boilers

## Boiler Manual



**WARNING**

This manual must only be used by a qualified heating installer/service technician. Failure to comply could result in severe personal injury, death or substantial property damage.

Part number 550-141-887/0800

# Contents

Please read before proceeding ..... 3

1 Prepare boiler location ..... 4-7

2 Venting ..... 8-13

3 Prepare boiler ..... 14

4 Water piping ..... 15-17

5 Gas piping ..... 18

6 Field wiring ..... 19

7 Jacket installation ..... 19

8 Start-up ..... 20

9 Checkout procedure ..... 21

10 Operation ..... 22-25

11 Service and maintenance ..... 26-31

12 Troubleshooting ..... 32-41

13 Replacement parts ..... 42-45

14 Dimensions ..... 46

15 Ratings ..... 47

## Hazard definitions

The following defined terms are used throughout this manual to bring attention to the presence of hazards of various risk levels or to important information concerning the life of the product.

- DANGER** Indicates presence of hazards that **will cause severe** personal injury, death or substantial property damage.
- WARNING** Indicates presence of hazards that **can cause severe** personal injury, death or substantial property damage.
- CAUTION** Indicates presence of hazards that **will or can cause minor** personal injury or property damage.
- NOTICE** Indicates special instructions on installation, operation or maintenance that are important but not related to personal injury or property damage.

# Please read before proceeding

## Installer

**WARNING**

Read all instructions before installing. Follow all instructions in proper order to prevent personal injury or death.

- Consider piping and installation when determining boiler location.
- Any claims for damage or shortage in shipment must be filed immediately against the transportation company by the consignee.

## User

- This manual is for use only by your qualified heating installer/service technician.
- Please refer to the User's Information Manual for your reference.
- We recommend regular service by a qualified service technician, at least annually.

**NOTICE**

When calling or writing about the boiler— Please have the boiler model number from the boiler rating label and the CP number from the boiler jacket. You may list the CP number in the space provided on the Installation and service certificate found on page 21.

**WARNING**

Failure to adhere to the guidelines on this page can result in severe personal injury, death or substantial property damage.

### When servicing boiler —

- To avoid electric shock, disconnect electrical supply before performing maintenance.
- To avoid severe burns, allow boiler to cool before performing maintenance.

### Boiler operation —

- Do not block flow of combustion or ventilation air to boiler.
- Should overheating occur or gas supply fail to shut off, do not turn off or disconnect electrical supply to circulator. Instead, shut off the gas supply at a location external to the appliance.
- Do not use this boiler if any part has been under water. Immediately call a qualified service technician to inspect the boiler and to replace any part of the control system and any gas control that has been under water.

### Boiler water —

- Do not use petroleum-based cleaning or sealing compounds in boiler system. Water seal deterioration will occur, causing leakage between sections. This can result in substantial property damage.
- Do not use "homemade cures" or "boiler patent medicines". Serious damage to boiler, personnel and/or property may result.
- Continual fresh makeup water will reduce boiler life. Mineral buildup in sections reduces heat transfer, overheats cast iron, and causes section failure. Addition of oxygen and other gases can cause internal corrosion. Leaks in boiler or piping must be repaired at once to prevent makeup water.
- Do not add cold water to hot boiler. Thermal shock can cause sections to crack.

### Glycol — potential fire hazard —

All glycol is flammable when exposed to high temperatures. If glycol is allowed to accumulate in or around the boiler or any other potential ignition source, a fire can develop. In order to prevent potential severe personal injury, death or substantial property damage from fire and/or structural damage:

- Never store glycol of any kind near the boiler or any potential ignition source.
- Monitor and inspect the system and boiler regularly for leakage. Repair any leaks immediately to prevent possible accumulation of glycol.
- Never use automotive antifreeze or ethylene glycol in the system. Using these glycols can lead to hazardous leakage of glycol in the boiler system.

### Carbon monoxide detectors — Canada only

Installers must follow local regulations with respect to the installation of CO detectors and follow the manufacturer's stated maintenance schedule for this boiler.

# 1a Prepare boiler location — codes & checklist

## Installations must follow these codes:

- Local, state, provincial and national codes, laws, regulations and ordinances.
- National Fuel Gas Code, ANSI Z223/1—latest edition.
- Standard for Controls and Safety Devices for Automatically Fired Boilers, ANSI/ASME CSD-1 when required.
- National Electrical Code.
- Canada only — B149.1 or B149.2 Installation Code, CSA C22.1 Canadian Electrical Code Part 1 and any local codes.

**NOTICE**

The AHE boiler gas manifold and controls met safe lighting and other performance criteria when boiler underwent tests specified in ANSI Z21.13—latest edition.

## Before locating the boiler, check the following:

1. Check for nearby connection to:
  - System water piping
  - Venting connections
  - Gas supply piping
  - Electrical power
2. Check area around boiler. Remove any combustible materials, gasoline and other flammable liquids.

**WARNING**

Failure to keep boiler area clear and free of combustible materials, gasoline and other flammable liquids and vapors can result in severe personal injury, death or substantial property damage.

3. Boiler must be installed so that gas control system components are protected from dripping or spraying water or rain during operation or service.
4. If new boiler will replace existing boiler, check for and correct system problems, such as:
  - System leaks causing oxygen corrosion or section cracks from hard water deposits.
  - Lack of antifreeze in boiler water causing system and boiler to freeze and leak.
5. Boilers cannot be recessed into a wall.
6. Back vented boilers must be mounted on an outside wall.

# 1b Prepare boiler location — clearances

## Provide the following clearances:

1. Recommended minimum service clearances — See Table 1.
2. Recommended clearances for enclosed cabinet, alcove or closet — See Table 1.

## Flooring

Boiler must not be installed on or over carpeting.

**WARNING**

Do not install boiler on carpeting even if foundation is used. Fire can result, causing severe personal injury, death or substantial property damage.

## Residential garage installation

Take the following special precautions when installing the boiler in a residential garage. If the boiler is located in a residential garage, per ANSI Z223.1, paragraph 5.1.9:

- Mount the boiler a minimum of 18 inches above the floor of the garage to assure the burner and ignition devices will be no less than 18 inches above the floor.

**Table 1** Recommended minimum clearances

	Service clearances (Note 1)	Enclosed cabinet, alcove or closet clearances
Left side	1"	1"
Right side	6"	1"
Front	30"	1"
Top	3"	3"
Bottom	6"	6"

**Note 1:** If the suggested minimum clearances for service cannot be met, the AHE boiler must be removed from the wall for servicing. Piping will be disconnected. **System isolation valves and unions for the supply, return and gas lines must be provided.**

# 1C Prepare boiler location — vent system

## When removing boiler from existing common vent system:

At the time of removal of an existing boiler, the following steps shall be followed with each appliance remaining connected to the common venting system placed in operation, while the other appliances remaining connected to the common venting system are not in operation.

- a. Seal any unused openings in the common venting system.
- b. Visually inspect the venting system for proper size and horizontal pitch and determine there is no blockage or restriction, leakage, corrosion or other deficiencies which could cause an unsafe condition.
- c. Test vent system — Insofar as is practical, close all building doors and windows, and all doors between the space in which the appliances remaining connected to the common venting system are located, and other spaces of the building. Turn on clothes dryers and any appliance not connected to the common venting system. Turn on any exhaust fans, such as range hoods and bathroom exhausts, so they will operate at maximum speed. Do not operate a summer exhaust fan. Close fireplace dampers.

- d. Place in operation the appliance being inspected. Follow the operating instructions. Adjust thermostat so appliance will operate continuously.
- e. Test for spillage at draft hood relief opening after 5 minutes of main burner operation. Use the flame of a match or candle.
- f. After it has been determined that each appliance remaining connected to the common venting system properly vents when tested as outlined above, return doors, windows, exhaust fans, fireplace dampers, and any other gas-burning appliance to their previous conditions of use.

Any improper operation of common venting system should be corrected so the installation conforms with the National Fuel Gas Code, ANSI Z223.1—latest edition. Correct by resizing to approach the minimum size as determined using the appropriate tables in Part 11 of that code. Canadian installations must comply with B149.1 or B149.2 Installation Code.

## Wall thickness

See Table 2 below for wall thicknesses for venting.

**Table 2**

Wall Sleeve	Wall Thickness	
	Minimum	Maximum
5" - 9"	5"	9"
9" - 13"	9"	13"
13" - 24"	13"	24"

# 1d Prepare boiler location — air openings

## Combustion air

Combustion air must be ducted directly from outside to the AHE boiler air intake fitting. This method is defined as “direct vent” (also referred to as “sealed combustion”). Refer to Section 2, page 8, in this manual for venting instructions. Two options are available: side venting and back venting.

## Sizing air/ventilation openings

Provide openings in the boiler enclosure as described below. Air is required for ventilation to prevent overheating of boiler controls and boiler space. Air is also required for combustion of other appliances if located in the same space with an AHE boiler.

### WARNING

Provide adequate openings for ventilation and combustion air as required by the National Fuel Gas Code to ensure proper combustion and operation and to reduce the risk of severe personal injury, death or substantial property damage due to insufficient air.

## AHE with no other appliances in same space

No special air/ventilation openings are required for AHE installations provided the space is at least:

- 2,250 cubic feet total volume for AHE-45 or
- 3,000 cubic feet total volume for AHE-60.

For installations in spaces smaller than above (closet, for example), provide two openings for ventilation air. Each opening must be at least:

- 45 square inches for the AHE-45 or
- 60 square inches for the AHE-60.

Place one opening within 3 inches of the top of the boiler, the other opening within 3 inches of the bottom of the boiler.

## AHE sharing space with other appliances

Unless the space has a total volume of no less than 50

cubic feet for each 1,000 Btuh of total input of all appliances:

1. Provide two openings into the space, each opening providing at least 1 square inch free area per 1,000 Btuh of all appliances in the space. Locate one opening within 12 inches of the ceiling, the other opening within 12 inches of the floor.
2. For larger spaces (over 50 cubic feet total volume per 1,000 Btuh of all appliances), no additional air openings are required unless the space is categorized as of “tight construction” as defined below.

## Tight construction

ANSI Z223.1 defines unusually tight construction where:

- a. Walls and ceilings exposed to the outside atmosphere have a continuous water vapor retarder with a rating of 1 perm or less with openings gasketed, and...
- b. Weather-stripping has been added on openable windows and doors, and...
- c. Caulking or sealants are applied to areas such as joints around windows and door frames, between sole plates and floors, between wall-ceiling joints, between wall panels, at penetrations for plumbing, electrical, and gas lines, and in other openings.

For tight construction installations:

1. Provide two openings into the space, each opening providing at least 1 square inch free area per 1,000 Btuh of all appliances in the space. Locate one opening within 12 inches of the ceiling, the other opening within 12 inches of the floor.

## Louver allowance

The free area of openings means the area **after reduction for any installed louvers or grilles**. Be sure to consider this reduction when sizing the air openings.

## Exhaust fans and air movers

The appliance space must never be under a negative pressure unless all appliances are installed as direct vent. Always provide air openings sized not only to the dimensions required for the firing rate of all appliances, but also to handle the air movement rate of the exhaust fans or air movers using air from the building or space.

# 2a Venting — vent/air intake pre-installation

## General information

### NOTICE

Installations must comply with all local, state and national codes including National Fuel Gas Code, ANSI Z223.1—latest edition. Canadian installations must comply with B149.1 or B149.2 Installation Codes.

- Two venting options are available for AHE boilers — side venting and back venting.
- Refer to Section 1, pages 4-7, of this manual regarding requirements for:
  - vent system
  - clearances
  - air openings

## Vent/air intake termination

- Vent/air intake must not be obstructed.

### WARNING

Boiler will not operate if vent/air intake is plugged. Be sure that the vent/air intake is unobstructed to avoid possibility of severe personal injury, death or substantial property damage.

- Locate or guard the vent to prevent accidental contact by people or pets.
- Gases will form a white plume in winter. Plume could obstruct window view of nearby windows in multi-story buildings.
- Prevailing winds could cause freezing of condensate and water/ice buildup on buildings or plants.
- Locate or guard vent termination to prevent condensate from damaging exterior surfaces.
- Do not terminate vent above any door or window. Condensate can freeze, causing ice formations.

- Do not terminate vent in window well or stairwell.
- Vent must terminate:
  - AHE-45 — 9" from any opening where gases could enter building.
  - AHE-60 — 12" from any opening where gases could enter building.
  - Bottom of vent/air intake terminal — 12" above expected snowline.
  - Adjacent to public walkways — not less than 7 feet above grade.
  - At least 4 feet horizontally (and in no case above or below unless a 4 foot horizontal distance is maintained) from electric meters, gas meters, regulators, relief valves and other equipment.

## Wall preparation

- Boilers cannot be recessed into a wall. Back vented boilers must be mounted on an outside wall.
- Boiler can be mounted directly on wall, but not on or over carpeting, when conventional framing with 16" stud spacing available or wall is masonry.

### WARNING

Be sure wall structure will support boiler and its piping. If wall does not have 16-inch stud spacing or is not masonry, provide solid mounting surface. Use ½" plywood cut 26" high and width large enough to overlap two studs (minimum 22½" width). Refer to dimensions table on page 46 and note boiler weight. Purchase 3" x ⅜" toggle bolts to anchor boiler to plywood.

- See page 46 for boiler dimensions.

# 2b Venting — side venting installation

## Select location

Review all connection, clearance and vent/air intake considerations before selecting location. See Figure 1 for side venting clearance access to outside wall.

## Prepare mounting panel

### Inside

Refer to Figure 3, below, and Figure 32, page 44. Choose right or left instructions based on venting direction.

1. Remove right (or left) knockouts.
2. Remove right (or left) intake and exhaust cover plates and discard.
3. Cut round opening in top exhaust gasket using new cover plate as template. Attach gasket and cover plate.
4. Seal back intake and exhaust holes by placing a generous amount of silicone sealant on the back side of the mounting panel around each opening. See Figure 2.
5. Mount blank cover plate (provided) over openings using (4) #10 x 1/2" Phillips screws (provided).

Continued next page...

**Figure 1** Side venting access to outside wall

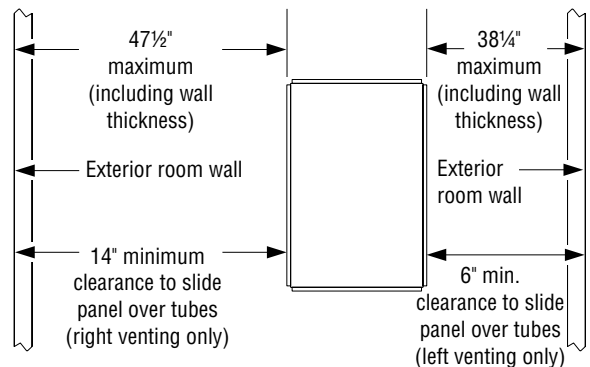

Note: Tubes can be enclosed minimum of 1" clearance from tubes to combustible material. 88701

**Figure 2** Sealant application

**WARNING**

Sealant must be placed on stainless steel portion of exhaust (top) opening to provide gas-tight seal. Failure to seal holes gas-tight can cause flue gas spillage and carbon monoxide emissions, resulting in severe personal injury, death or substantial property damage.

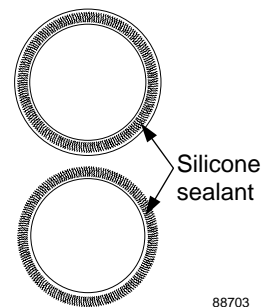

88703

**Figure 3** Side venting mounting panel

- ① Exhaust cover plate and gasket (Factory-assembled on mounting panel. Remove right or left for venting direction.)
- ② Intake cover plate and gasket (Factory-assembled on mounting panel. Remove right or left for venting direction.)
- ③ Supplied with boiler
- ④ Supplied with kit

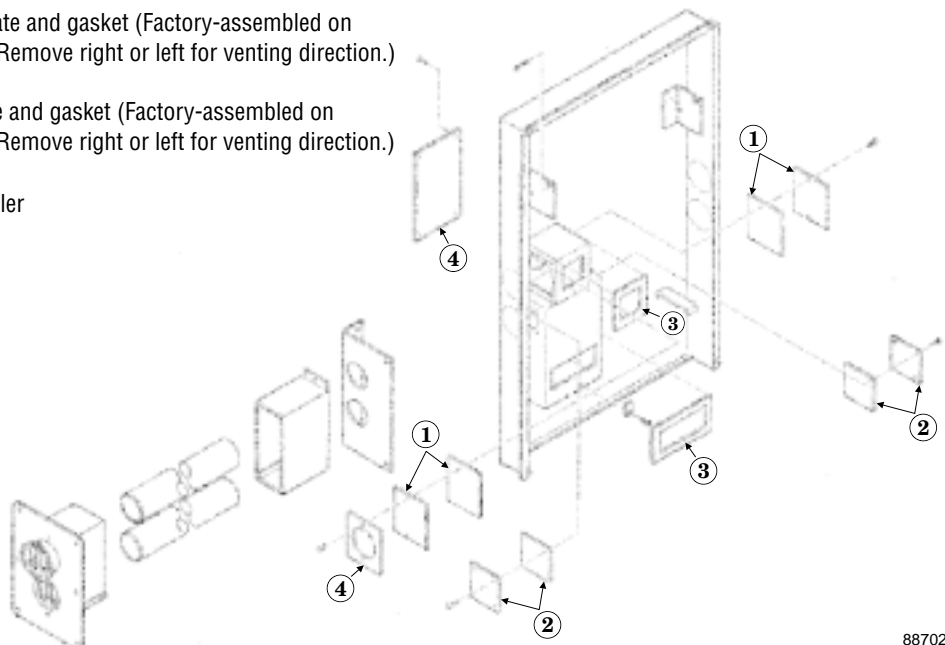

88702

# 2b Venting — side venting installation con't

## Prepare mounting panel continued

6. Determine boiler location. See Manual Section 2a on page 8 and “Select location” on page 9.

**DANGER**

Before installing boiler and venting, inspect wall locations for obstructing piping and electrical supply. Failure to do so will result in severe personal injury, death or substantial property damage.

7. Level and tape mounting panel template to wall at desired height between studs.

**WARNING**

Center of mounting panel bolt holes must be in line with 16" studs unless extra support board is provided. Refer to “Wall preparation” on page 8. Failure to mount panel properly can result in severe personal injury, death or substantial property damage.

8. To locate side wall vent:
  - a. Measure from floor to center line of top exhaust tube on large template.
  - b. Subtract 1/4" per foot of vent run from step “a”. Vent tubes must pitch down from boiler.
  - c. Level and tape small template on side wall. Height of top exhaust center line is distance in step “b”. Note correct “up” position for right or left side venting.
9. Mark location of vent/air intake opening through template on side wall.
10. Remove template and cut opening in wall.

### Outside

11. The following material is required:
  - a. outside wall plate assembly (see Figure 4 on this page and Figure 8, page 11).
  - b. silicone sealant.
  - c. (4) #10 x 1 1/4" common screws (provided) or (4) wall anchors (not provided) for masonry wall only.
  - d. screwdriver.
  - e. drill with small bit (to start screws if necessary).
  - f. level.
12. Using outside wall plate as template, level and locate mounting holes.
13. Place a generous amount of silicone sealant around wall opening. See Figure 5, right and Figure 8 on page 11.
14. Insert outside wall plate assembly into opening and attach to wall.

**Figure 4** Outside wall plate assembly

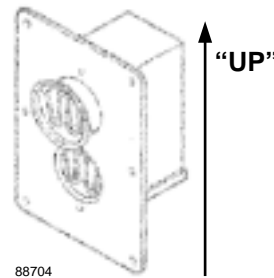

**Figure 5** Silicone sealant

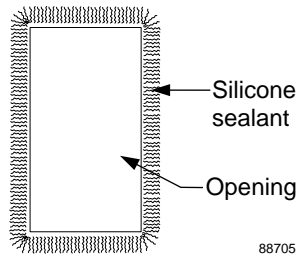

**Figure 6** Measure tube lengths

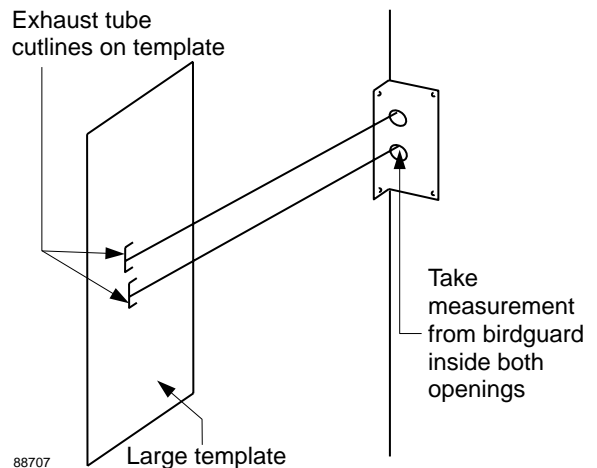

## 2b Venting — side venting installation con't

### Prepare mounting panel continued

#### Inside

15. Insert wall sleeve (see Figure 32, item 1, page 44) into outside wall plate assembly.
16. Measure tube lengths. See Figure 6 on page 10.
17. Cut tube lengths. Top tube will be longer than bottom tube.
18. Final location of boiler will be determined by proper slope to vent/air intake tubes. Vent must slope downward from boiler  $\frac{1}{4}$ " per foot of vent run to prevent outside moisture from draining into boiler. See Figure 7, right.
19. Check vent tube slope:
  - a. Place top tube in top opening of outside wall plate (See Figure 32, items 1 and 2 on page 44).
  - b. Measure from floor to bottom of tube at side wall.
  - c. Measure from floor to bottom of tube at plenum box end of tube.
  - d. Distance should differ  $\frac{1}{4}$ " per foot of vent run (length of top tube). Adjust large template to locate bottom-of-tube mark at correct slope.
  - e. Remove tube.
20. Drill stud holes in template. Remove template.
21. Apply generous bead of silicone sealant around insertion end of tubes, 1" from end of tube.
22. Place tubes in openings. See Figure 8.
23. Place inside wall plate (see Figure 32, page 44, item 3) over tubes, against wall.
24. Slide mounting panel (Figure 32, page 44, item 5) over tubes. Tubes will extend into plenum box openings.
25. Securing mounting panel to studs with (2)  $\frac{5}{16}$ " x  $2\frac{1}{4}$ " lag screws provided. Use toggle bolts on plywood.
26. Place a continuous amount of silicone sealant around junctions of tubes and plenum boxes. Also place sealant in four (4) screw holes where blank cover plate was attached to the bottom (air intake) plenum box. Smooth sealant to provide complete seal. See Figure 8.
27. Fasten inside wall plate, using (4) #10 x  $\frac{1}{2}$ " screws provided.

### Reassembly

When vent/air intake system is disconnected for any reason, reassemble and reseal per this manual section.

#### WARNING

Silicone sealant must be used where indicated. Vent/air intake system must be sealed gas-tight to prevent possibility of flue gas spillage and carbon monoxide emissions, resulting in severe personal injury, death or substantial property damage.

Figure 7 Vent slope

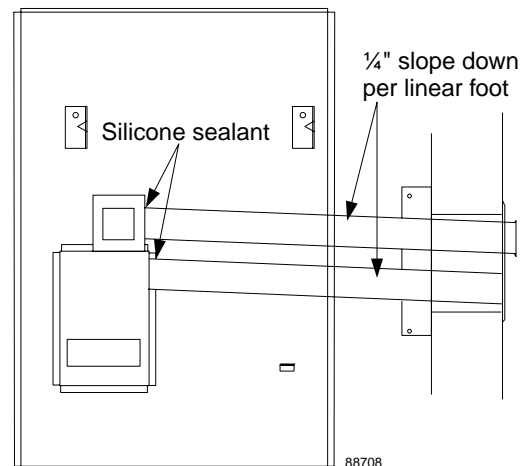
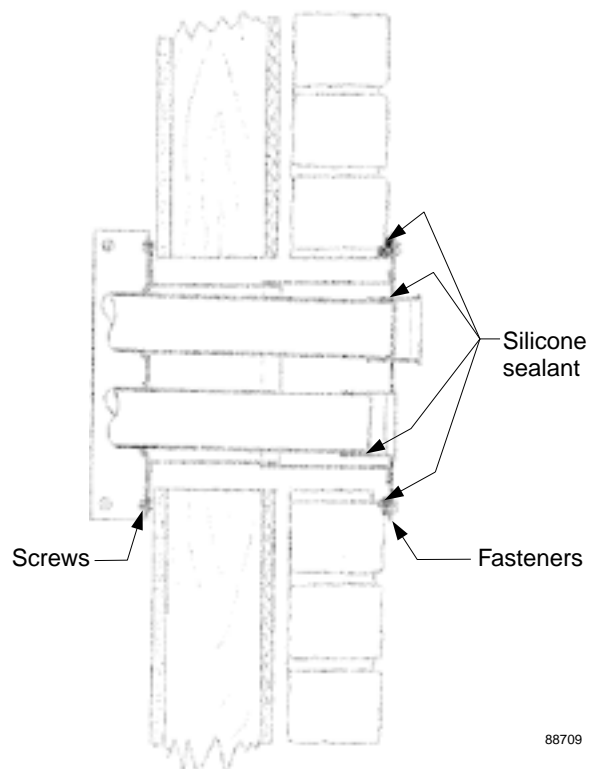

Figure 8 Side venting installation



## 2C Venting — back venting installation

### Prepare mounting panel

#### Inside

**DANGER**

Inspect boiler wall location for obstructing piping and electrical supply prior to drilling and boiler installation. Failure to do so will cause severe personal injury, death or substantial property damage.

1. Level and tape template to wall at desired height between wall studs

**WARNING**

Center of mounting panel bolt holes must be in line with 16" studs unless support board is provided. Refer to "Wall preparation" on page 8. Failure to mount panel properly can result in severe personal injury, death or substantial property damage.

2. Mark location on wall of vent/air intake opening (small rectangle in template). Remove template.
3. Cut opening in wall.

#### Outside

4. Take the following materials outside:
  - a. outside wall plate assembly (see Figure 4 on page 11).
  - b. silicone sealant.
  - c. level.
  - d. (4) #10 x 1½" common screws (provided)
  - e. (4) wall anchors (not provided), for masonry walls only.
  - f. screwdriver.
  - g. drill with small bit (to start screws if necessary).
5. Using plate as template, level, locate and start mounting holes.
6. Place a generous amount of silicone sealant around vent/air intake opening. See Figure 5, page 11.
7. Insert outside wall plate assembly into opening and attach to wall.

# 2c Venting — back venting installation con't

## Prepare mounting panel continued

### Inside

8. Insert inside cover plate assembly into opening. Inside wall sleeve fits into outside wall sleeve. "Up" stamp must be up.
9. Insert tube into top opening, until it stops. Mark length 1/2" longer than plate. Cut tube.
10. Repeat step 9 for lower tube.
11. Remove inside cover plate assembly.
12. Apply generous bead of silicone sealant around insertion end of tubes, 1" from end of tube.

**WARNING**

Silicone sealant must be used where indicated. Vent/air intake system must be sealed gas-tight to prevent possibility of flue gas spillage and carbon monoxide emissions, resulting in severe personal injury, death or substantial property damage.

13. Insert longer tube in top opening of outside plate, shorter tube in bottom opening. See Figure 9.
14. Fit inside wall plate into opening. See step 8, above. Tubes should protrude from plate. Do not fasten plate to wall. See Figure 9.
15. Apply continuous bead of silicone sealant around junctions of tubes and inside cover plate. Smooth sealant to provide thorough seal. See Figure 10.
16. Using mounting panel as template, align (2) plenum box openings over intake and exhaust tubes. Level and mark location of (2) lag screw holes. Drill (2) 3/16" holes.
17. Hang mounting panel. Use (2) 5/16" x 2 1/4" lag screws provided. Use toggle bolts on plywood.

## Reassembly

When vent/air intake system is disconnected for any reason, reassemble and reseal per this manual section.

**WARNING**

Silicone sealant must be used where indicated. Vent/air intake system must be sealed gas-tight to prevent possibility of flue gas spillage and carbon monoxide emissions, resulting in severe personal injury, death or substantial property damage.

Figure 9 Back venting installation

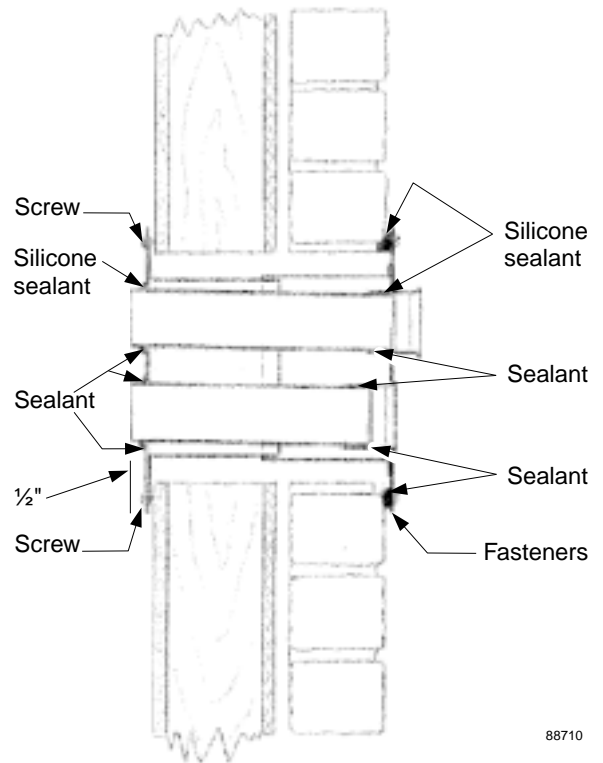
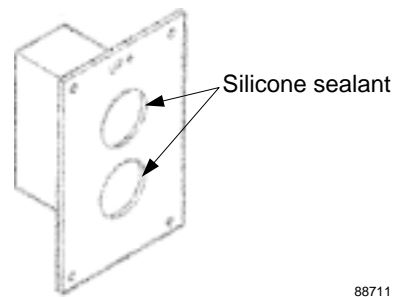

Figure 10 Inside cover plate



# 3 Prepare boiler — placement and setup

## Hang boiler on mounting panel

1. Remove crate top and wrapper. Leave bottom skid attached to boiler to aid hanging boiler.
2. Cut bottom shipping strap located around boiler base. Do not cut upper strap.
3. Place generous amount of silicone sealant around plenum box openings on mounting panel. Set gaskets (provided) in place. See Figure 11.
4. Carefully lift and hang boiler on mounting panel hooks. Boiler hanger holes are located on upper boiler back. Bottom skid may be adjusted to allow boiler to hang on hooks.

**CAUTION** Boiler is heavy. Care must be taken to prevent personal injury or damage to boiler.

5. Cut upper strap. Remove skid.
6. Fasten cotter pin in hole located in left mounting panel hook to prevent boiler from lifting off hooks.
7. Use (1) #10 x 1/2" Phillips screw with holding bracket to secure boiler. See Figure 11.

Figure 11

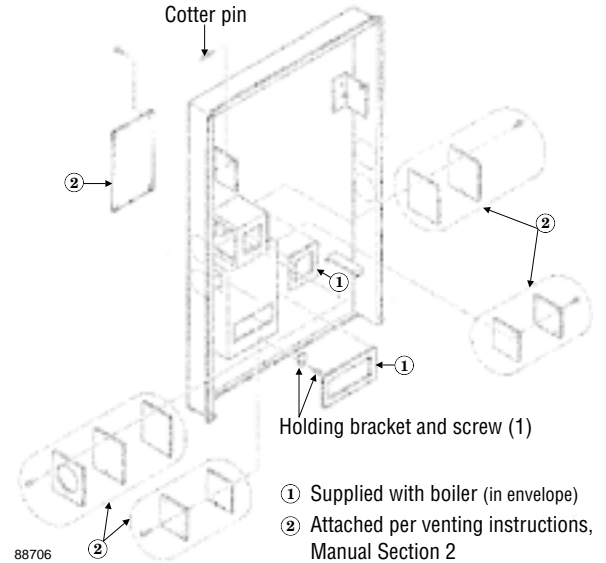

## Inspect orifices and burners

1. Remove burner inlet plenum cover (see Figure 30, item 9, page 42).
2. Carefully remove ignitor and ignitor gasket. Use caution — ignitor is brittle and can break.

**DANGER** Wait several minutes until ignitor cools down before removing. Failure to do so will cause severe personal injury.

3. Check for correctly-size burner orifices. See Table 3 for sizing. (The orifice size is stamped on the orifice spud barrel.)

**DANGER** Correctly-sized manifold orifices must be used. Failure to do so will result in severe personal injury, death or substantial property damage.

4. Replace ignitor, ignitor gasket and burner inlet plenum cover.

Table 3 Manifold orifice sizing

Location	Natural gas		Propane gas	
	0-2,000 ft.	over 2,000 ft.	0-2,000 ft.	over 2,000 ft.
U.S.	#48	(see Note)	1.15 mm	(see Note)
	#48	#49	1.15 mm	#58
Canada	0-2,000 ft.	2,000-4,500 ft.	0-2,000 ft.	2,000-4,500 ft.
	#48	#49	1.15 mm	#58

Note: For elevations above 2,000 feet, contact your local Weil-McLain sales office for details.

# 4a Water piping — general information

## General piping information

1. Pipe as shown in Figure 12. Refer to I=B=R Installation and Piping Guides for additional recommendations.
2. If system is to comply with ASME or Canadian requirements, an additional high temperature limit is needed. Install control in supply outlet piping close to the boiler. See page 23 for wiring.
3. A low water cutoff device is required for hot water boilers installed above radiation level or by certain state or local codes or insurance companies. Block temperature switch, installed as standard equipment on the boiler, monitors surface temperature, causing gas controls to shut down should low water condition occur.
4. Install cold water fill as shown in Figure 12.
5. Where heat distributing units are below boiler, provide a drain valve at low point in system.
6. Use zone valves for multiple zone applications. Refer to manufacturer's literature for wiring and application.

## Expansion tank

1. A correctly-sized diaphragm-type expansion tank must be provided. Ensure expansion tank will handle boiler and system water volume and temperature.
2. Follow tank manufacturer's sizing procedure to determine proper size.
3. Locate expansion tank as shown in Figure 12.

## External heat exchangers

AHE boilers can be used with storage tank/heat exchanger unit for domestic hot water. Boiler/tank combination should be installed and wired in accordance with tank manufacturer's instructions, which will also show any additional components required. A zone valve must be installed to regulate production of hot water.

## Relief valve

Verify relief valve is installed with spindle in vertical position. See Figure 33, item 1, page 45 and the tag attached to the relief valve for manufacturer's instructions.

**Figure 12** Water piping diagram

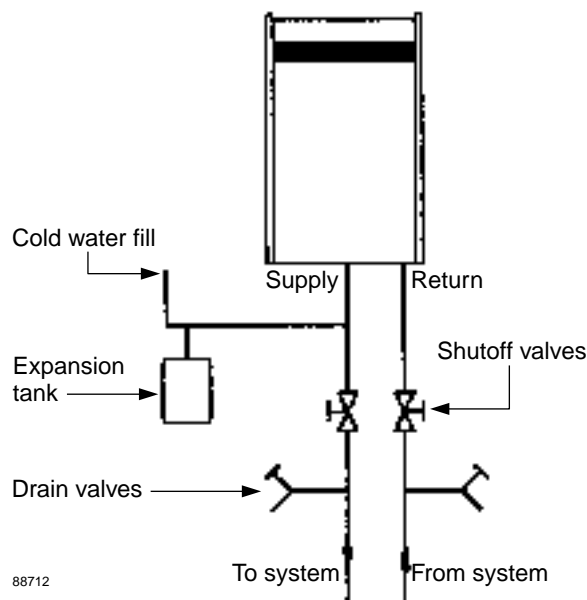

Note: Use zone valves in each circuit for multiple circuit applications.

### WARNING

To avoid water damage or scalding due to relief valve operation:

- Discharge line must be connected to relief valve outlet and run to a safe place of disposal. Terminate the discharge line to eliminate possibility of severe burns should the valve discharge.
- Discharge line must be as short as possible and be the same size as the valve discharge connection throughout its entire length.
- Discharge line must pitch downward from the valve and terminate at least 6" above the floor drain where any discharge will be clearly visible.
- The discharge line shall terminate plain, not threaded, with a material serviceable for temperatures of 375 °F or greater.
- Do not pipe the discharge to any place where freezing could occur.
- No shutoff valve shall be installed between the relief valve and boiler, or in the discharge line. Do not plug or place any obstruction in the discharge line.
- Failure to comply with the above guidelines could result in failure of the relief valve to operate, resulting in possibility of severe personal injury, death or substantial property damage.
- Test the operation of the valve after filling and pressurizing system by lifting the lever. Make sure the valve discharges freely. If the valve fails to operate correctly, replace it with a new relief valve.

# 4a Water piping — general information con't

## Water treatment

See **WARNING** on page 3 for important information regarding boiler water.

For unusually hard water areas or low pH water conditions (below 7.0) consult local water treatment company.

## Freeze protection

See **WARNING** on page 3 for important information regarding glycol hazard.

**WARNING** Do not use ethylene glycol, automotive or undiluted antifreeze. Severe personal injury or death can result.

1. Determine antifreeze quantity according to system water content. Boiler water content is listed on page 47.
2. Follow antifreeze manufacturer's instructions.
3. A 50% solution of propylene glycol/water provides maximum protection to about -30 °F. Do not exceed 50% solution.
4. Local codes may require a back flow preventer or actual disconnect from city water supply.
5. When using antifreeze in a system with automatic fill, install a water meter to monitor water makeup. Glycol will leak before the water begins to leak, causing glycol level to drop. Added water will dilute the antifreeze, reducing the freeze protection level.

# 4b Water piping — low temp systems

## Low water temperature boiler-bypass piping

1. Do not use conventional bypass piping on radiant panel systems or systems requiring water temperature lower than boiler temperature. For these systems, follow piping diagram shown in Figure 13.
2. Adjust valves to maintain system supply and return at design temperature.

Figure 13 Low temp boiler-bypass piping

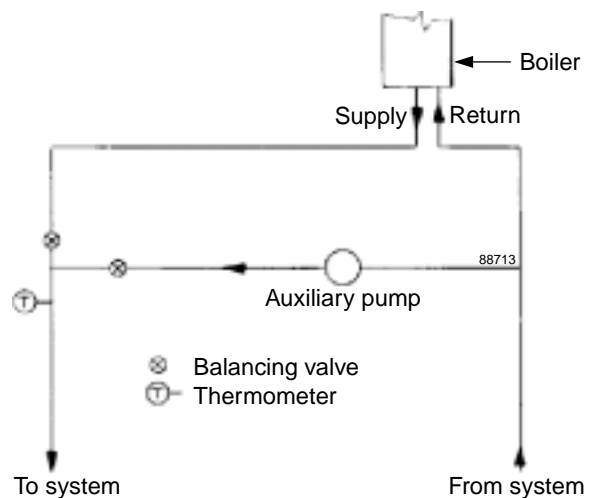

# 4c Water piping — refrigeration systems

## Prevent chilled water from entering boiler

Install boiler so that chilled medium is piped in parallel with the heating boiler. Use appropriate valves to prevent chilled medium from entering boiler. See Figure 14 for typical installation of balancing valve and check valve.

If boiler is connected to heating coils located in air handling units where they can be exposed to refrigerated air, use flow control valves or other automatic means to prevent gravity circulation during cooling cycle.

Figure 14 Piping refrigeration systems

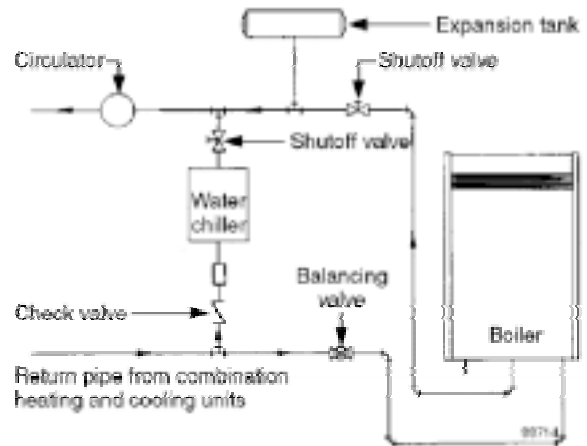

# 4d Water piping — pressure test

## Perform hydrostatic pressure test

Pressure test boiler before attaching gas piping or electrical supply.

1. Close shutoff valves between boiler and system. Remove air vent cap on top of boiler and open air vent on circulator/mixing valve 2 full turns.
2. Feed water into the boiler through cold water fill — **Do not exceed 45 psig**. Boiler is filled and air is vented when boiler air vent valve is depressed and water spurts from valve. Screw cap back on air vent on boiler and close air vent on circulator/mixing valve completely, then open both one full turn. Turn off cold water fill.
3. Test at 45 psig for more than 10 minutes.

**WARNING**

Do not leave boiler unattended. Cold water fill could expand and cause excess pressure, resulting in severe personal injury, death or substantial property damage.

4. Make sure constant gauge pressure has been maintained throughout test. Check for leaks. Repair if found.

**WARNING**

Leaks must be repaired at once. Failure to do so can damage boiler, resulting in substantial property damage.

**DANGER**

Do not use petroleum-based cleaning or sealing compounds in boiler system. Severe damage to boiler will occur, resulting in substantial property damage.

5. With shutoff valves still closed, attach hose adapter and hose to one drain valve and discharge water through other drain valve until no air is present. Use line water pressure.
6. Close both drain valves. Remove hose and adapter.
7. Open cold water fill. **Fill pressure should be between 30-40 psig.**
8. Open shutoff valves.

# 5 Gas piping

## Natural gas piping

1. Refer to Table 4 for pipe length and diameter. Base on rated boiler input (divide by 1,000 to obtain cubic feet per hour). Table 4 is only for gas with specific gravity, 0.06, with a pressure drop through the gas piping of 0.03" w.c. For additional gas pipe sizing information, refer to ANSI Z223.1 (or B149.1 or B149.2 for Canadian installations).
2. Inlet gas pressure:
  - maximum: 13" w.c.
  - minimum: 5" w.c.
  - manifold pressure: 3½" w.c.
3. Install 100% lockup gas pressure regulator in supply line if inlet pressure exceeds 13" w.c. Adjust for 13" w.c. maximum.

## Propane gas piping

1. Contact gas supplier to size pipes, tanks and 100% lockup gas pressure regulator.
2. Adjust propane supply regulator provided by gas supplier for 13" w.c. maximum pressure.
2. Inlet gas pressure:
  - maximum: 13" w.c.
  - minimum: 11" w.c.
  - manifold pressure: 10" w.c.
3. Install 100% lockup gas pressure regulator in supply line if inlet pressure exceeds 13" w.c. Adjust for 13" w.c. maximum.

**Table 4**

Pipe capacity for 0.60 specific gravity natural gas

Length of pipe (feet)	Capacity of pipe (in cubic feet of gas per hour)		
	½"	¾"	1"
10	132	278	520
20	92	190	350
30	73	152	285
40	63	130	245
50	56	115	215
75	45	93	175
100	38	79	150
150	31	64	120

## Connecting gas piping to boiler

1. Refer to Figure 15 for recommended gas piping.
2. Use pipe dope compatible with propane gases. Apply sparingly only to male threads of pipe joints so that pipe dope does not block gas flow.

**WARNING**

Failure to apply pipe dope as detailed above can result in severe personal injury, death or substantial property damage.

3. Install drip leg at inlet of gas connection to boiler. See Figure 15. Where local utility requires drip leg to be extended to the floor, use appropriate length of pipe between cap and tee.
4. Install manual main shutoff gas valve and ground joint union in gas piping according to local utility requirements.
5. In Canada, when using manual main shutoff gas valve, it must be identified by the installer.
6. Support piping with hangers, not by boiler or its accessories.
7. Purge all air from gas supply piping.
8. Before placing boiler in operation, check boiler and its gas connection for leaks.

**WARNING**

Do not check for gas leaks with open flame — use bubble test. Failure to use bubble test or check for gas leaks can cause severe personal injury, death or substantial property damage.

- a. Close manual main shutoff valve during any pressure test less than 13" w.c.
- b. Disconnect boiler and gas valve from supply piping during any pressure test greater than 13" w.c.

**Figure 15** Gas supply piping

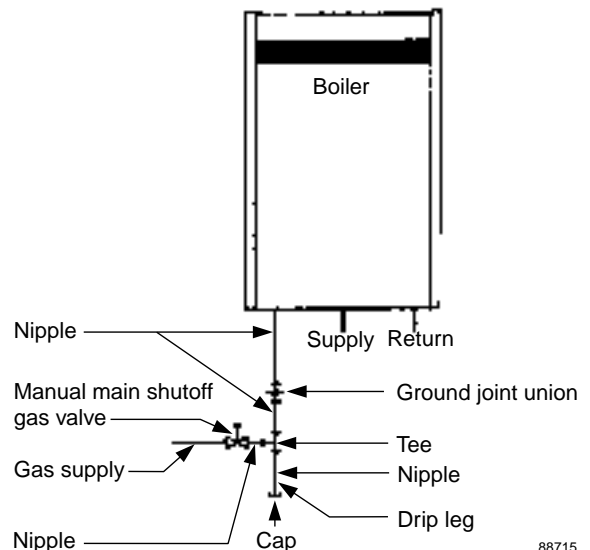

88715

## 6 Field wiring

### WARNING

For your safety, turn off electrical power supply at service entrance panel before making any electrical connections to avoid possible shock hazard. Failure to do so can cause severe personal injury or death.

### NOTICE

Wiring must be N.E.C. Class 1. Boiler must be electrically grounded as required by National Electrical Code ANSI/NFPA 70—latest edition. If original wiring as supplied with boiler must be replaced, use only type 105 °C wire or equivalent. If original rollout thermal fuse element wire as supplied with boiler must be replaced, type 200 °C wire or equivalent must be used.

### Electrical installation must comply with:

1. National Electrical Code and any other national, state, provincial or local codes or regulations.
2. In Canada, CSA C22.1 Canadian Electrical Code Part 1, and any local codes.

### Wiring connections

Boiler is shipped with controls completely wired.

Electrical supply to boiler should be a separate branch circuit with a fused disconnect (15 amp).

Wire electric supply to supply leads in junction box. Refer to wiring diagram inside jacket door or on page 23.

For addition of zone valves to system, a separate transformer is required to power zone valves. Refer to manufacturer's recommendations for sizing requirements and wiring recommendations. Zoning with circulators requires a relay for each circuit.

### Thermostat

1. Connect thermostat to control wire harness inside boiler, as shown on wiring diagram inside jacket door, or manual page 23.
2. Install on inside wall away from influences of drafts, hot or cold water pipes, lighting fixtures, television, sunrays, or fireplaces.
3. If thermostat has a heat anticipator, set heat anticipator in thermostat to match power requirements of equipment connected to it. Refer to wiring diagram on jacket door. For multiple zoning, set the heat anticipator to match the current draw of the zone valve.

## 7 Jacket installation

Assemble jacket as shown in Figure 31, page 43, using the appropriate Jacket Assembly Carton for your boiler model.

### Mounting

1. Bend corner tabs on mounting panel toward boiler.
2. Slide jacket assembly (without front panel) over mounted boiler.
3. Upper back lip hooks over top of mounting panel.
4. Jacket swings toward mounting panel and snaps into place.
5. Slide front panel upper lip under grill. Place against side panels. Slide down until lower lip hooks behind bottom panel edge.

## 8a Start-up

### Final check before starting boiler

#### Boiler water

Review Manual Section 4, pages 15 through 17, regarding water piping, treatment, freeze protection and system pressure testing.

Verify boiler is filled with water.

#### Check for gas leaks

##### WARNING

Before starting the boiler and during initial operation, smell near the floor and around the boiler for gas odorant or any unusual odor. Do not proceed with start-up if there is any indication of a gas leak. Repair any leak at once.

##### WARNING

Propane boilers only — Your propane supplier mixes an odorant with the propane to make its presence detectable. In some instances, the odorant can fade, and the gas may no longer have an odor. Before start-up (and periodically thereafter), have the propane supplier verify the correct odorant level in the gas.

### Start the boiler

Follow the “Operating instructions” found on pages 24-25 to start the boiler. Refer to Section 8b, below, if boiler fails to start.

### Check burner flames

1. Refer to Figure 30, item 9 on page 42. Remove burner input plenum cover.
2. Visually inspect burner flames:
  - **Proper** main burner flame (see Figure 16):
    - a. Yellow-orange streaks may appear (caused by dust).
  - **Improper** main burner flame:
    - a. Overfired — Large flames.
    - b. Underfired — Small flames.
    - c. Lack of primary air — Yellow tipping on flames (sooting will occur).

**Figure 16** Typical main burner flame

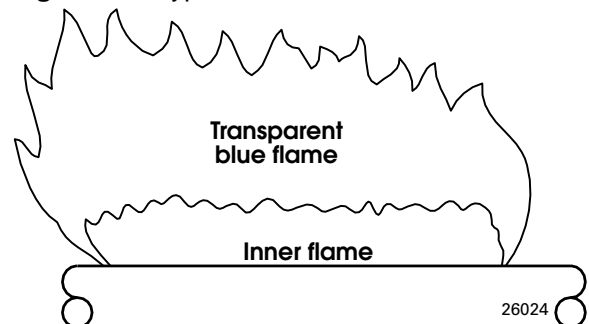

## 8b Start-up — if boiler fails to start...

### Check for:

1. Loose connections, blown fuse or service switch?
2. High limit switch set below boiler water temperature?
3. Thermostat set below room temperature?
4. Gas not turned on at meter?
5. Gas not turned on at boiler (manual main shutoff and gas valve)?
6. Incoming gas pressure less than:
  - 5" w.c. for natural gas?
  - 11" w.c. for propane gas?

If none of the above corrects the problem, refer to “Troubleshooting” section, pages 32-41.

# 9 Checkout procedure

- Boiler and heat distribution units filled with water or antifreeze solution?
- Automatic air vent cap open two full turns during air purging procedure, then closed and opened one turn?
- Air purged from system?
- Air purged from gas piping? Piping checked for leaks?
- Followed operating instructions on boiler or in Manual Section 10c, pages 24-25, for proper start-up?
- Proper burner flame observed? Refer to “Check burner flames”, Manual Section 8a, page 20.
- Test limit control — While burners are operating, move indicator on limit control below actual boiler water temperature. The blower and burners should go off while circulator continues to operate. Raise setting on limit control above boiler water temperature and burners should reignite.
- Test additional field-installed controls — Test additional high limits or other controls, test for operation as outlined by manufacturer. Burners should be operating and should go off when controls are tested. When controls are restored, burners should reignite.
- Test ignition system safety device:
  - a. Connect voltmeter to outlet side of gas valve.
  - b. Start boiler, allowing for normal start-up cycle to occur and main burners to ignite.
  - c. With main burners on, manually shut off gas supply at manual main shutoff gas valve. Burners should go off.
  - d. Open manual main shutoff gas valve. Manometer should confirm there is no gas flow.
  - e. Pilot will relight, flame sensing element will sense pilot flame and main burners will reignite.
- Set limit control(s) to system temperature requirements. Adjust balancing valves and controls to provide design temperature to system.
- Verify thermostat heat anticipator set properly? Refer to “Thermostat” on page 19, and wiring diagram on jacket door or in manual page 23.
- Cycle boiler with thermostat — Raise to highest setting and verify boiler goes through normal start-up cycle. Lower to lowest setting and verify boiler goes off.
- Measure natural gas input:
  - a. Operate boiler 10 minutes.
  - b. Turn off other appliances.
  - c. At natural gas meter, measure time (in seconds) required to use one cubic foot of gas.
  - d. Calculate gas input:
 
$$\frac{3600 \times 1000}{\text{number of seconds from step c}} = \text{Btuh}$$
  - e. Btuh calculated should approximate input rating on boiler rating label.
- Check manifold gas pressure by connecting manometer to downstream test tapping on main gas valve. Manifold pressure for natural gas should be 3.5" w.c. and for propane gas should be 10" w.c.
- Observe several operating cycles for proper operation.
- Set room thermostat to desired room temperature.
- Fill in “Installation and service certificate” below?
- Review all instructions shipped with this boiler with owner or maintenance person. Return instructions to envelope and give to owner or place in pocket inside front panel in boiler.

## Installation and service certificate

Boiler model \_\_\_\_\_ Series \_\_\_\_\_ CP number \_\_\_\_\_ Date installed \_\_\_\_\_

Measured Btuh input \_\_\_\_\_

- Installation instructions have been followed.
- Check out sequence has been performed.
- Above information is certified to be correct.
- Information received and left with owner/maintenance person

Installer \_\_\_\_\_ (company) \_\_\_\_\_ (address) \_\_\_\_\_ (phone)

\_\_\_\_\_  
 (installer’s signature)

# 10a Operation — sequence

Figure 17 shows the AHE boiler control module sequence of operation with status light indications. For more information, refer to “Troubleshooting” section beginning on page 32.

**Figure 17** Control module sequence of operation

Steps	Call for heat?	POWER	TSTAT CIRC	LIMIT	PRESS SWITCH	FLAME	Timing
(Following step 8, cycle goes back to step 1.)							
<b>1. Standby</b> • Waiting for call for heat	<b>NO</b>						—
<b>2. Call for heat</b> • Circulator on • Blower on	<b>YES</b>						—
<b>3. Limit circuit</b> • Limit controls closed • Block switch contacts closed	<b>YES</b>						—
<b>4. Pressure circuit</b> • Pressure switch contacts closed • Ignitor heating	<b>YES</b>						35 sec
<b>5. Flame proven</b> • Gas valve open • Ignitor remains on • Boiler producing heat	<b>YES</b>						6 sec
<b>6. Limit cycle</b> • Limit circuit open • Gas valve closed	<b>YES</b>						—
<b>7. Flame outage *</b> • Flame out • Boiler recycles	<b>YES</b>						—
<b>8. Thermostat satisfied</b> • Circulator off • Blower postpurge	<b>NO</b>						30 sec
		or	= "ON"		= "OFF"		

\* If flame is not proven in 4 seconds, boiler recycles 2 times to retry for ignition before going into lockout. Recycle igniter timing is 30 seconds. Postpurge and prepurge are performed on every cycle. In event of lockout, ignition control will automatically restore sequence of operation after either:  
 1 hour waiting period.  
 Opening and closing of thermostat circuit.  
 Removal of 120 VAC power for at least 45 seconds.

# 10b Operation — wiring diagram

Figure 18

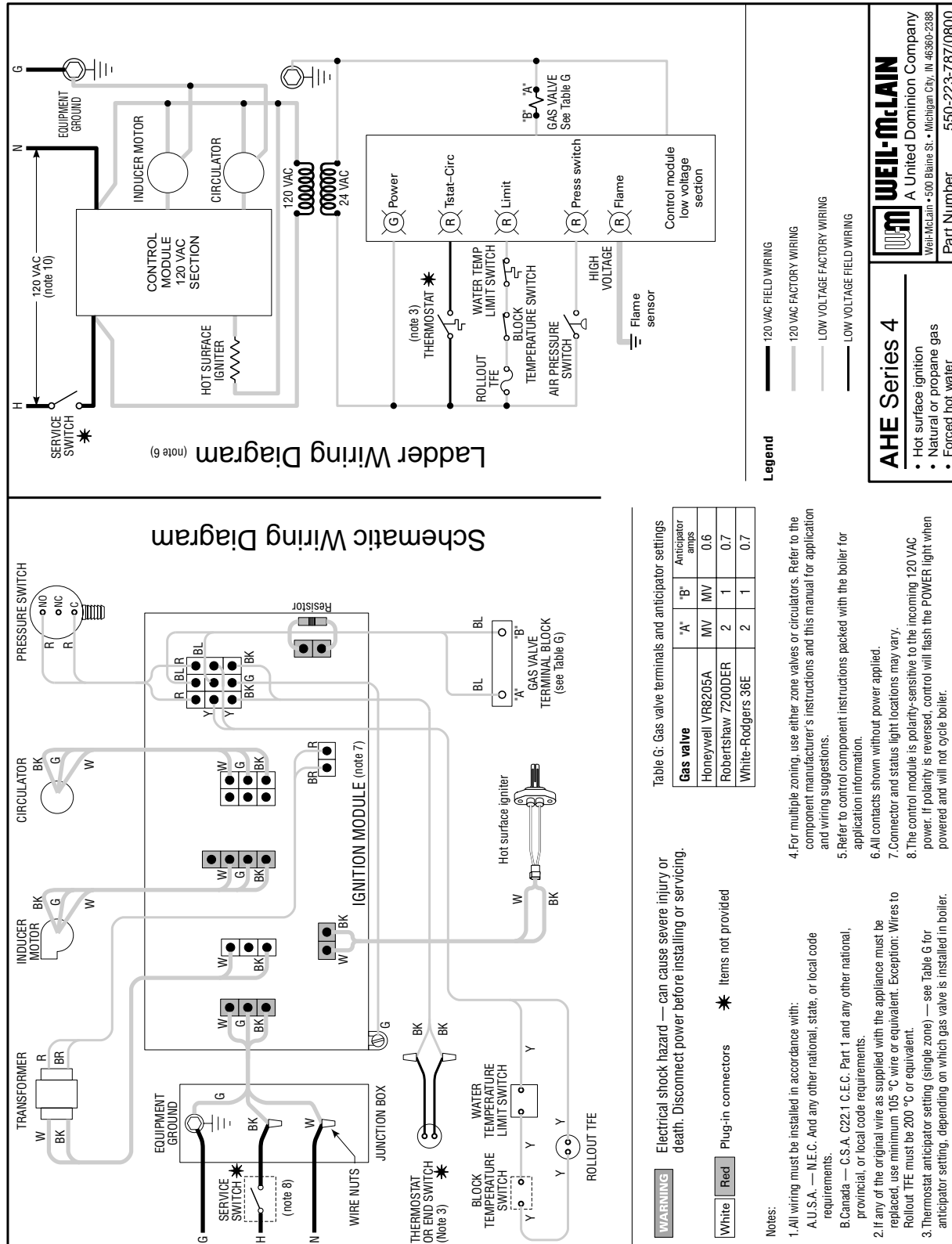

**AHE Series 4**

- Hot surface ignition
- Natural or propane gas
- Forced hot water

**WEIL-McLAIN**  
 A United Dominion Company  
 Weil-McLain • 500 Baines St. • Michigan City, IN 46360-2388

Part Number 550-223-787/0800

# 10c Operation — operating instructions

## Robertshaw 7200 gas valve

### FOR YOUR SAFETY READ BEFORE OPERATING

**WARNING**

If you do not follow these instructions exactly, a fire or explosion may result causing property damage, personal injury or loss of life.

- A. This appliance is equipped with an ignition device which automatically lights the pilot. **Do not** try to light the pilot by hand.
- B. Before **OPERATING**, smell all around the appliance area for gas. Be sure to smell next to the floor because some gas is heavier than air and will settle on the floor. See below.
- C. Use only your hand to turn the gas control knob. Never use tools. If the knob will not turn by hand, don't try to repair it, call a qualified service technician. Force or attempted repair may result in a fire or explosion.
- D. Do not use this appliance if any part has been under water. Immediately call a qualified service technician to inspect the appliance and to replace any part of the control system and any gas control, which has been under water.

#### WHAT TO DO IF YOU SMELL GAS

- Do not try to light any appliance.
- Do not touch any electric switch; do not use any phone in your building.
- Immediately call your gas supplier from a neighbor's phone. Follow the gas supplier's instructions.
- If you cannot reach your gas supplier, call the fire department.

### OPERATING INSTRUCTIONS

1. **Stop!** Read the safety information above on this label.
2. Set the thermostat to lowest setting.
3. Turn off all electrical power to the appliance.
4. Remove control access panel.
5. This appliance is equipped with an ignition device which automatically lights the burner. Do not try to light the burner by hand.
6. Depress and move **selector arm** counterclockwise ↶ to **OFF**. **Note:** Selector arm cannot be moved to **OFF** unless selector arm is depressed slightly. Do not force.
7. Wait five (5) minutes to clear out any gas. Then smell for gas, including near the floor. If you smell gas, **STOP!** Follow "**B**" in the safety information above. If you don't smell gas, go to the next step.
8. Turn **selector arm** clockwise ↷ to **ON**.
9. Turn on all electric power to the appliance.
10. Set thermostat to desired setting.
11. If the appliance will not operate, follow the instructions "**To Turn Off Gas To Appliance**" below and call your service technician or gas supplier.
12. Replace control access panel.

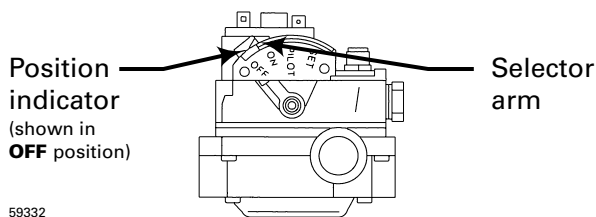

### TO TURN OFF GAS TO THE APPLIANCE

1. Set the thermostat to lowest setting.
2. Turn off all electric power to the appliance if service is to be performed.
3. Remove control access panel.
4. Depress and move **selector arm** counterclockwise ↶ to **OFF**. Do not force.
5. Replace control access panel.

# 10c Operation — operating instructions continued

## Honeywell VR8205 and White-Rodgers 36E gas valves

### FOR YOUR SAFETY READ BEFORE OPERATING

**WARNING**

If you do not follow these instructions exactly, a fire or explosion may result causing property damage, personal injury or loss of life.

- A. This appliance is equipped with an ignition device which automatically lights the pilot. **Do not** try to light the pilot by hand.
- B. Before **OPERATING**, smell all around the appliance area for gas. Be sure to smell next to the floor because some gas is heavier than air and will settle on the floor. See below.
- C. Use only your hand to turn the gas control knob. Never use tools. If the knob will not turn by hand, don't try to repair it, call a qualified service technician. Force or attempted repair may result in a fire or explosion.
- D. Do not use this appliance if any part has been under water. Immediately call a qualified service technician to inspect the appliance and to replace any part of the control system and any gas control, which has been under water.

#### WHAT TO DO IF YOU SMELL GAS

- Do not try to light any appliance.
- Do not touch any electric switch; do not use any phone in your building.
- Immediately call your gas supplier from a neighbor's phone. Follow the gas supplier's instructions.
- If you cannot reach your gas supplier, call the fire department.

### OPERATING INSTRUCTIONS

1. **Stop!** Read the safety information above on this label.
2. Set the thermostat to lowest setting.
3. Turn off all electrical power to the appliance.
4. Remove control access panel.
5. This appliance is equipped with an ignition device which automatically lights the burner. Do not try to light the burner by hand.
6. Turn **gas control knob** clockwise ↻ to **OFF**.
7. Wait five (5) minutes to clear out any gas. Then smell for gas, including near the floor. If you smell gas, **STOP!** Follow "B" in the safety information above. If you don't smell gas, go to the next step.
8. Turn **gas control knob** counterclockwise ↺ to **ON**.
9. Turn on all electric power to the appliance.
10. Set thermostat to desired setting.
11. If the appliance will not operate, follow the instructions "**To Turn Off Gas To Appliance**" below and call your service technician or gas supplier.
12. Replace control access panel.

88731

**White-Rodgers 36E Gas valve**

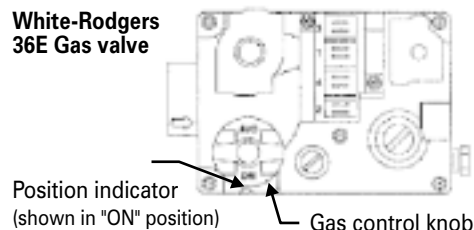

**Honeywell VR8205 Gas valve**

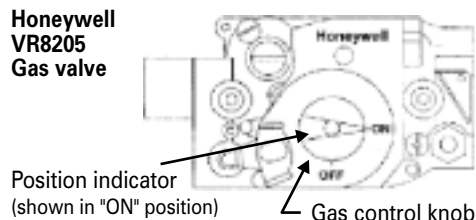

### TO TURN OFF GAS TO THE APPLIANCE

1. Set the thermostat to lowest setting.
2. Turn off all electric power to the appliance if service is to be performed.
3. Remove control access panel.
4. Turn **gas control knob** clockwise ↻ to **OFF**. Do not force.
5. Replace control access panel.

# 11a Service and maintenance — schedule

**WARNING**

Follow the “Service and maintenance” procedures given throughout this manual and in component literature shipped with the boiler. Failure to perform the service and maintenance could result in damage to the boiler or system. Failure to follow the directions in this manual and component literature could result in severe personal injury, death or substantial property damage.

**Table 5** Service and maintenance schedules

<b>Service technician</b> (see following pages for instructions)		<b>Owner maintenance</b> (see AHE User’s Information Manual for instructions)	
<b>ANNUAL START-UP</b>	<b>Inspect:</b>	<b>Daily</b>	<ul style="list-style-type: none"> <li>• Check boiler area</li> <li>• Check air openings</li> <li>• Check boiler pressure/temperature gauge</li> </ul>
	<ul style="list-style-type: none"> <li>• Reported problems</li> <li>• Boiler area</li> <li>• Air openings</li> <li>• Flue gas vent system (and air piping)</li> <li>• Main burner flames</li> <li>• Water piping</li> <li>• Boiler heating surfaces</li> <li>• Burners and base</li> </ul>	<b>Monthly</b>	<ul style="list-style-type: none"> <li>• Check boiler piping</li> <li>• Check venting system</li> <li>• Check boiler relief valve</li> <li>• Check automatic air vents</li> <li>• Main burner flames</li> </ul>
	<b>Service:</b>	<b>Periodically</b>	<ul style="list-style-type: none"> <li>• Test low water cutoff</li> <li>• Clean vent termination and air intake screens</li> </ul>
	<ul style="list-style-type: none"> <li>• Cleaning boiler heating surfaces</li> <li>• Blower motor</li> <li>• Oiled-bearing circulators</li> </ul>	<b>Every 6 months</b>	<ul style="list-style-type: none"> <li>• Operate relief valve</li> </ul>
	<b>Start-up:</b>	<b>End of season</b>	<ul style="list-style-type: none"> <li>• Shut down procedure</li> </ul>
<ul style="list-style-type: none"> <li>• Perform start-up per manual</li> </ul>			
<b>Check/test:</b>			
<ul style="list-style-type: none"> <li>• Gas piping</li> <li>• Cold fill and operating pressures</li> <li>• Air vents and air elimination</li> <li>• Blower motor assembly</li> <li>• Circulator with mixing valve</li> <li>• Limit controls and cutoffs</li> <li>• Expansion tank</li> <li>• Boiler relief valve</li> </ul>			
<b>Review:</b>			
<ul style="list-style-type: none"> <li>• Review with owner</li> </ul>			

# 11b Service and maintenance — annual start-up

**WARNING**

The boiler should be inspected and started annually, at the beginning of the heating season, only by a qualified service technician. In addition, the maintenance and care of the boiler designated in Table 5, page 26, and explained on the following pages must be performed to assure maximum boiler efficiency and reliability. Failure to service and maintain the boiler and system could result in equipment failure.

**WARNING**

The boiler contains ceramic fiber and fiberglass materials. Use care when handling these materials per instructions on page 48 of this manual. Failure to comply could result in severe personal injury.

**WARNING**

Electrical shock hazard — **Turn off power to the boiler before any service operation** on the boiler except as noted otherwise in this manual. Failure to turn off electrical power could result in electrical shock, causing severe personal injury or death.

**DANGER**

**Do not use petroleum-based cleaning or sealing compounds** in boiler system. Severe damage to boiler will occur, resulting in substantial property damage.

## □ Inspect

### Reported problems

Inspect any problems reported by the owner and correct before proceeding.

### Boiler area

**WARNING**

To prevent potential of severe personal injury, death or substantial property damage, do not store combustible materials, gasoline or any other flammable vapors or liquids near the boiler. Remove immediately if found.

### Air openings

1. Verify that combustion and ventilation air openings to the boiler room and/or building are open and unobstructed.
2. Verify that boiler vent discharge is clean and free of obstructions.

### Flue gas vent system (and air piping)

1. Visually inspect entire flue gas venting system (and air piping) for blockage, deterioration or leakage. Repair any joints that show signs of leakage in accordance with vent manufacturer's instructions. All joints must be gas-tight. When air is ducted to boiler, verify that air inlet hose is connected and properly sealed.

**WARNING**

Failure to inspect for the above conditions and have them repaired can result in severe personal injury or death.

2. The vent/air intake terminals must not be obstructed or boiler will not function. If vent/air

intake piping is disassembled, it must be reassembled and resealed according to Manual Section 2, beginning on page 9.

**WARNING**

Vent/air intake system must be sealed gas-tight to prevent possibility of flue gas spillage and carbon monoxide emissions, causing severe personal injury, death or substantial property damage.

### Main burner flames

1. Visually inspect main burner flames as directed under "Start-up" on page 20.

### Water piping

1. Check the boiler interior piping and all system piping for signs of leaks.
2. Repair any leaks before proceeding.

**WARNING**

Eliminate all system or boiler leaks. Continual fresh makeup water will reduce boiler life. Minerals can build up in sections, reducing heat transfer, overheating cast iron and causing equipment failure. Leaking water may also cause severe property damage.

# 11b Service and maintenance — annual start-up

## □ Inspect

### Boiler heating surfaces

1. Turn off power to the boiler following “To Turn Off Gas To The Appliance” instructions found in the Operating Instructions on pages 24 and 25. Do not drain the system unless exposure to freezing temperatures will occur. If antifreeze is used with system, do not drain.
2. Remove cleanout plate “B”. See Figure 19.
3. If the interior shows evidence of soot, follow “Cleaning boiler heating surfaces” on page 29 to remove the blower assembly and clean the boiler if necessary after close inspection of the boiler heating surfaces. If there is evidence of rusty scale deposits, check the water piping and control system to make sure the boiler return water temperature is properly maintained (per this manual).
4. Replace all boiler components before returning to service.
5. Check inside and around boiler for evidence of any leaks from the boiler. If found, locate source of leaks and repair.

### Burners and base

1. After turning off power to the boiler, remove cover plate “A”. See Figure 19.
2. Unplug ignitor before removing. Carefully remove ignitor (see Figure 20) and ignitor gasket. Use caution — ignitor is brittle and can break. Do not touch ignitor surface with bare hands, Body oils can cause failure of the carbide. Replace ignitor gasket if original gasket is frayed or damaged.

**DANGER**

Wait several minutes until ignitor cools down before removing. Failure to do so will cause severe personal injury.

3. Inspect burners and all other components in the boiler base.
4. If burners must be cleaned, remove burners and vacuum or brush burners to remove dust and lint.
  - a. Remove wires from rollout thermal fuse element. (Figure 30, item 7, page 42.)
  - b. Remove burner plenum cover. (Figure 30, item 9, page 42.)
  - c. Pull off burner clips
  - d. Remove main burners.
5. Inspect the base insulation. Pay attention to the **WARNING** on page 48 regarding working with insulation materials. The combustion chamber is lined with high temperature refractory material. Check to make sure the base insulation is secure against three sides of the base. If refractory material is damaged or displaced, do not operate boiler.
6. Replace burners, ignitor gasket and ignitor.

**DANGER**

When replacing burners, burner tubes must be seated in their slots in the back with the openings face up. Front of burner tubes must rest fully over main burner orifices. Main burner orifices must inject down center of burner. Failure to do so will cause severe personal injury, death or substantial property damage.

Figure 19

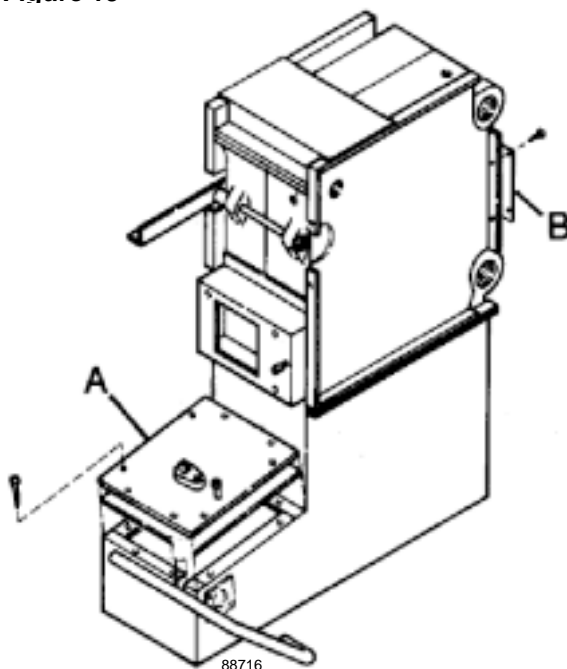

Figure 20 Ignitor



continued

## ❑ Service

### Cleaning boiler heating surfaces

**NOTICE**

Gas boilers burn cleanly — check to see if flue cleaning is necessary.

1. Shut down boiler following “To Turn Off Gas To The Appliance” instructions found on pages 24 and 25. Do not drain the system unless exposure to freezing temperatures will occur. If antifreeze is used with system, do not drain.
2. Remove entire jacket assembly and boiler insulation. Pay attention to the **WARNING** on page 48 regarding working with insulation materials.
3. Unplug ignitor before removing. Carefully remove ignitor (see Figure 20, page 28) and ignitor gasket. Use caution — ignitor is brittle and can break.

**DANGER**

Wait several minutes until ignitor cools down before removing. Failure to do so will cause severe personal injury.

4. Remove burners:
  - a. Remove wires from rollout thermal fuse element.
  - b. Remove burner plenum cover. (Figure 30, item 9, page 42.)
  - c. Pull off burner clips.
  - d. Remove main burners.
5. Remove cleanout plate from right side of boiler. See Figure 21.
  - a. If no soot is present, proceed to Step 9.
  - b. If soot has accumulated, continue to the next step.
6. Remove entire blower assembly:
  - a. Remove 2 screws on mounting plate.
  - b. Remove white and red tubing.
  - c. Pull unit from boiler.
7. Thoroughly clean all visible heating surfaces and remove soot. See Figure 22.
8. Replace blower motor assembly:
  - a. Reseal all surfaces for gas-tight seal.
  - b. Replace screws and tubing.
9. Clean burners. See “Burners and base” on page 28.
10. Replace burners. See Step 3.

**DANGER**

When replacing, burner tubes must be seated in slots in the back with the openings face up. Front of burner tubes must rest fully over main burner orifices. Main burner orifices must inject down center of burner. Failure to do so will cause severe personal injury, death or substantial property damage.

11. Reseal and replace cleanout plates.
12. Replace insulation and jacket assembly.

## ❑ Start-up

1. Perform start-up procedures given in this manual, page 20.
2. Verify cold fill pressure is correct and that fill system is working properly.
3. Verify antifreeze level (if used) is at the right concentration and that inhibitor level is correct.
4. Check gas piping, per Manual Section 5, page 18 and Section 8a, page 20.
5. Read the “Operating instructions” on boiler label or on pages 24 and 25, applying to your boiler.
6. Start the boiler following the “Operating instructions” found on pages 24 and 25 of this manual.

Figure 21

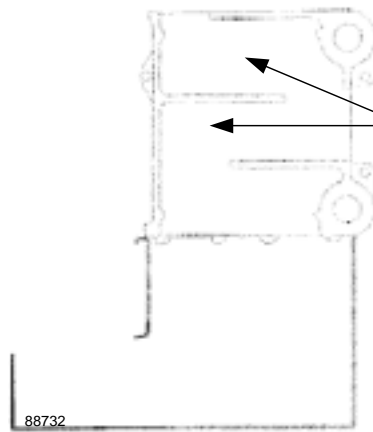
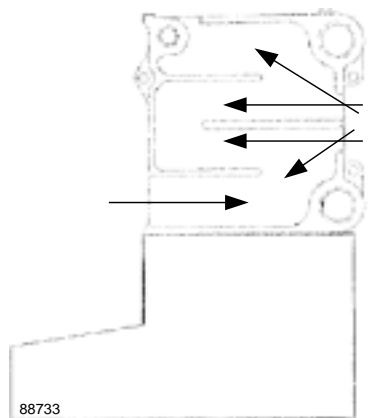

Figure 22



# 11b Service and maintenance — annual start-up

## ❑ Check/test

### Gas piping

1. Sniff near floor and around boiler area for any indication of a gas leak.
2. Test gas piping using bubble test, per Manual Section 5, page 18, if there is any indication of a leak.

### Cold fill and operating pressures

1. While the system is cold, note the pressure reading on the boiler pressure/temperature gauge. Verify that cold fill pressure is correct.
2. Watch the pressure as the boiler and system heat up to ensure pressure rise is normal. Too high a rise would indicate a waterlogged or undersized expansion tank.

### Air vents and air elimination

1. Inspect automatic air vents. Also inspect air separators to ensure they are operational.
2. The cap must be unscrewed one turn to allow air to escape.
3. See Figure 23. If the air vent is leaking, remove cap “A” and briefly push valve “B” and then release to clean the valve seat.
4. Replace cap “A” by twisting all the way onto valve “B” and then unscrew one turn.

### Blower motor assembly

Blower develops induced draft to supply combustion air to boiler. Cooling fan circulates air for controls contained within the jacket. Assembly includes 120/601, 3250 RPM, 1 Amp. blower motor, blower fan and cooling fan. See Figure 30, item 21 on page 42.

Check and test the blower motor assembly to ensure it is operating correctly. Replace, if necessary, per the following instructions:

1. Remove white pressure switch tube from blower mounting plate.
2. Disconnect (2) black wires from junction box to blower motor at wire nuts.
3. Remove (3) #10 x 1/2" Phillips screws from blower backing plate.
4. Break silicone seal and remove entire blower assembly.
5. Remove excess silicone sealant from mounting and backing plates.
6. Reseal around blower backing plate with silicone sealant, including the covers.

**WARNING**

Boiler must be sealed gas-tight. Failure to do so can cause flue gas spillage and carbon monoxide emissions, resulting in severe personal injury, death or substantial property damage.

7. Start screw closest to wall.
8. Install new blower motor assembly by sliding over back screw. Replace other screws and tighten. Make sure blower motor outlet is sealed gas-tight against gasket on mounting panel.

**WARNING**

Failure to seat outlet gas-tight can cause flue gas spillage and carbon monoxide emissions, resulting in severe personal injury, death or substantial property damage.

9. Connect wires on new blower motor to (2) black wires from junction box. Use wire nuts.
10. Reattach white pressure switch tube to hose barb on blower mounting plate.

### Circulator with mixing valve

The circulator provides forced water circulation to hot water heating system. The mixing valve prevents condensation in the boiler.

Check and test the circulator to determine proper operation. If replacement is necessary, use the following instructions:

1. Replace cartridge (Figure 24, item 1):
  - a. Remove casing screws.
  - b. Replace cartridge per manufacturer’s instructions.
  - c. Replace casing screws.
2. Replace mixing valve element (Figure 24, item 2):
  - a. Follow manufacturer’s instructions provided with replacement.

**Figure 23** Automatic air vent, typical

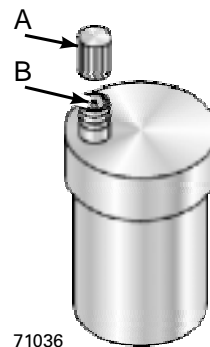

**Figure 24** Circulator with mixing valve

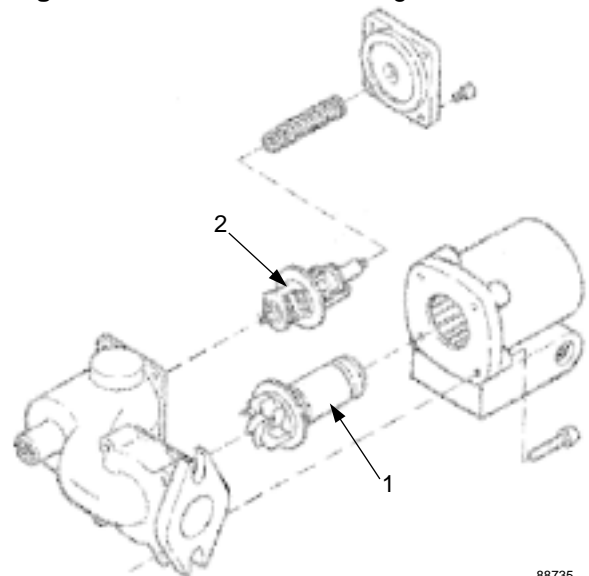

continued

**□ Check/test** continued

**Limit controls and cutoffs**

1. Inspect and test the boiler limit control. Verify operation by turning control set point below boiler temperature. Boiler should cycle off. Return dial to original setting.
2. Inspect and test additional limit controls or temperature plug switch (see Figure 25) installed on system. Make sure aluminum foil on boiler insulation does not come in contact with temperature plug switch terminals, preventing boiler operation.

**Expansion tank**

Expansion tanks provide space for water to move in and out as the heating system water expands due to temperature increase or contracts as the water cools.

1. AHE boilers require a diaphragm-type expansion tank with at least one automatic air vent. See Figure 12 on page 15 for suggested best location of the expansion tank.
2. If relief valve has tended to weep frequently, the expansion tank may be waterlogged or undersized. Check the following:
  - a. Check tank size to be sure it is large enough for the system.
  - b. If size is too small, add additional tank(s) as necessary to provide sufficient expansion.
  - c. If tank size is large enough, remove tank from system and check charge pressure (usually 12 psig for residential applications). If tank won't hold pressure, membrane has been damaged.

Replace tank.

**Boiler relief valve**

1. See Figure 26. Inspect the relief valve and lift the lever to verify flow as in the following warnings, excerpted from a relief valve manufacturer's warning label. Before operating any relief valve, ensure that it is piped with its discharge in a safe area to avoid severe scald potential. Read Manual Section 4a on page 15 before proceeding further.

**WARNING**

**Safety relief valves should be reinspected at least once every three years**, by a licensed plumbing contractor or authorized inspection agency, to ensure that the product has not been affected by corrosive water conditions and to ensure that the valve and discharge line have not been altered or tampered with illegally. Certain naturally occurring conditions may corrode the valve or its components over time, rendering the valve inoperative. Such conditions are not detectable unless the valve and its components are physically removed and inspected. This inspection must only be conducted by a plumbing contractor or authorized inspection agency — not by the owner. Failure to reinspect the boiler relief valve as directed could result in unsafe pressure buildup, which can result in severe personal injury, death or substantial property damage.

**WARNING**

Following installation, the **valve lever must be operated at least once a year** to ensure that waterways are clear. Certain naturally occurring mineral deposits may adhere to the valve, rendering it inoperative. When manually operating the lever, water will discharge and precautions must be taken to avoid contact with hot water and to avoid water damage. Before operating lever, check to see that a discharge line is connected to this valve directing the flow of hot water from the valve to a proper place of disposal, otherwise severe personal injury may result. If no water flows, valve is inoperative. Shut down boiler until a new relief valve has been installed.

2. After following the above warning directions, if the relief valve weeps or will not seat properly, replace the relief valve. Ensure that the reason for relief valve weeping is the valve a not over-pressurization of the system due to expansion tank waterlogging or undersizing.

**Figure 25**  
Temperature plug switch

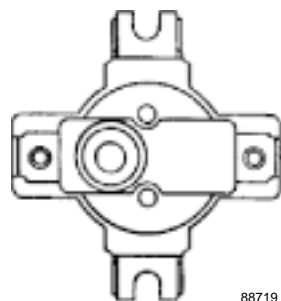

**Figure 26**  
Relief valve, typical

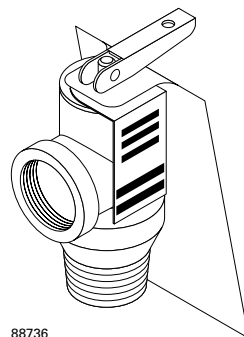

**□ Review**

1. Review the “User’s Information Manual” with the owner.
2. Emphasize the need to perform the maintenance schedule specified in the “User’s Information Manual” (and this manual as well).
3. Remind the owner of the need to call in a licensed contractor should the boiler or system exhibit any unusual behavior.
4. Remind the owner to follow the proper shutdown procedure and to schedule an annual start-up at the beginning of the next heating season.

# 12a Troubleshooting — procedure

**WARNING**

Label all wires prior to disconnection when servicing controls. Wiring errors can cause improper and dangerous operation.

**WARNING**

Never jumper (bypass) rollout thermal fuse element or any other device except for momentary testing as outlined in “Troubleshooting charts”, found on pages 35-41. Severe personal injury, death or substantial property damage can result.

## Before troubleshooting

1. Have the following items before troubleshooting
  - a. Voltmeter that can check 120 VAC and 24 VAC.
  - b. Microammeter with a minimum scale range of 0-25.
  - c. Continuity checker.
  - d. Inclined manometer with 0-2" w.c. range.
2. Check for 120 VAC (minimum 102 VAC to maximum 132 VAC) to boiler.
3. Make sure thermostat is calling for heat and contacts (including appropriate zone controls) are closed. Check for 24 VAC between thermostat wire nuts and ground.

## Check the following:

1. Wire connectors to control module are securely plugged in at module and originating control.
2. Air pressure switch hoses are properly and securely plugged in and are not damaged.
3. Gas pressures:
  - a. With boiler off:
    - 13" w.c. maximum natural or propane gas pressure upstream of gas valve.
  - b. With boiler on:
    - 5" w.c. natural gas pressure or 11" w.c. propane gas pressure upstream of gas valve.
    - 3 ½" w.c. natural gas pressure or 10" w.c. propane gas pressure downstream tapping on gas valve (can be adjusted by regulator on gas valve).

## VERIFY PROPER OPERATION AFTER SERVICING.

# 12b Troubleshooting — air pressure switch

**NOTICE** Make sure boiler water temperature must be 100 °F or cooler before starting procedure to obtain appropriate readings.

## Check pressure switch setting

1. Remove both air pressure switch hoses from air pressure switch.
2. Install tees and tubing as shown in Figure 27 to inclined manometer.
3. Close the manual main gas valve and set thermostat to call for heat. Blower will run but main burners will not ignite.
4. Check for 24 VAC between normally open terminal on pressure switch and ground. See Figure 28.

## Troubleshooting air pressure reading

1. If manometer reading is at least 0.55" w.c. pressure, but there is not 24 VAC across normally open terminal on pressure switch and ground, replace the pressure switch.
2. If manometer reading is lower than 0.55" w.c., look for possible causes:
  - blockage in hoses
  - obstruction in blower housing outlet
  - loose blower wheel on motor shaft
  - blower back plate not sealed properly
  - blockage in exhaust, air intake pipe or termination.

## Return to normal operation

When pressure reading is correct and air pressure switch is operating properly, remove tees and reinstall tubing to air pressure switch.

**Figure 27** Manometer connections

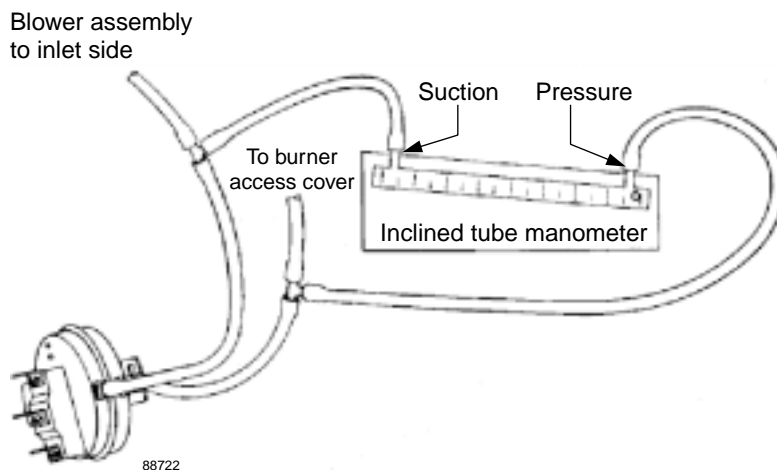

**Figure 28** Air pressure switch

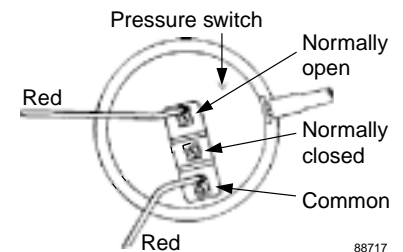

# 12c Troubleshooting — control module

**NOTICE** Make sure ground wiring is installed per wiring diagram. Good grounding is extremely important for proper operation.

**WARNING** Solder or water splatter between plugs and circuit board can cause improper operation of control module. Place a shield over the boiler internal controls and components during installation.

### POWER and TSTAT CIRC lights flashing

Usually indicates stray voltage on external thermostat circuit wires or return water temperature entering boiler sections has not reached 130 °F within 20 minutes.

### POWER and LIMIT lights flashing alternately

Usually indicates that limit circuit failed to cut off boiler at high temperature — return water temperature sensor has sensed water over 235 °F.

### POWER and PRESS SWITCH lights flashing

Usually indicates pressure switch is closed when it should not be, or pressure switch failed to close within 5 minutes of blower starting.

### POWER and FLAME lights flashing

Usually indicates control has had three unsuccessful ignition attempts or sensed flame when it shouldn't be there.

## Control indicator lights

### Lockout modes

See Charts 1 through 8 in this manual section for detailed troubleshooting procedures.

To reset control after a lockout, turn off power at the 120 VAC service switch or turn down all thermostats. Wait 45 seconds. Then restore power or call for heat.

After an over-temperature lockout (**POWER** and **LIMIT** lights flashing), the control will only reset after interruption of 120 VAC for 45 seconds.

### POWER light flashing alone

Usually indicates reversed polarity of 120 VAC power wires.

### Non-lockout modes

#### TSTAT CIRC light flashing alone

Usually indicates return water temperature sensor detects water at boiler return pipe less than 40 °F. Both internal circulators will run continuously, even with no call for heat, until temperature rises.

#### LIMIT light flashing alone

Usually indicates an open or shorted return water temperature sensor.

## Troubleshooting the control module

See Figure 29 for location of harness plug receptacles and plugs on the control module.

**Figure 29** Control module harness plug receptacle and indicator light locations

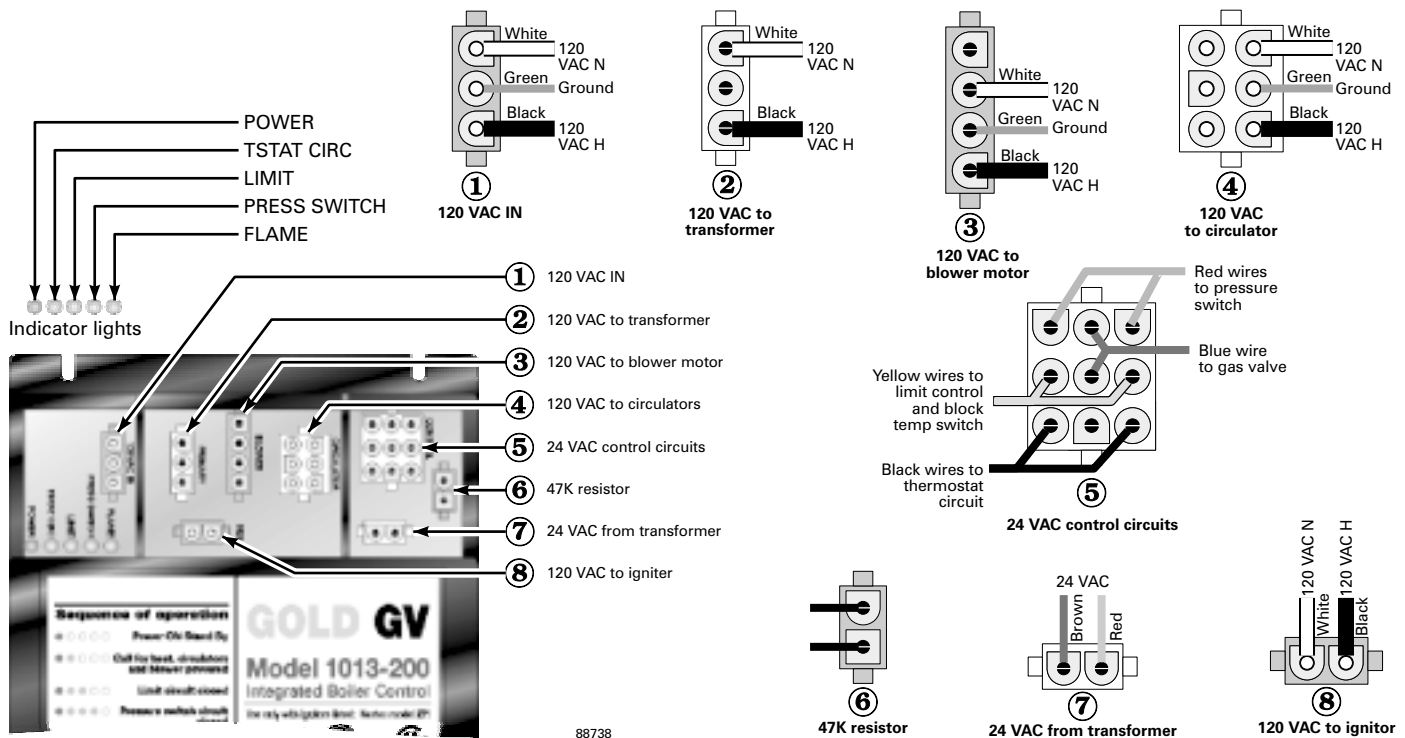

# 12d Troubleshooting — charts

## CHART 1 — Troubleshooting POWER light status

**WARNING** Electrical shock hazard — Wherever you see **▲TURN OFF POWER▲**, follow the instructions. Failure to follow instructions could result in severe personal injury, death or substantial property damage.

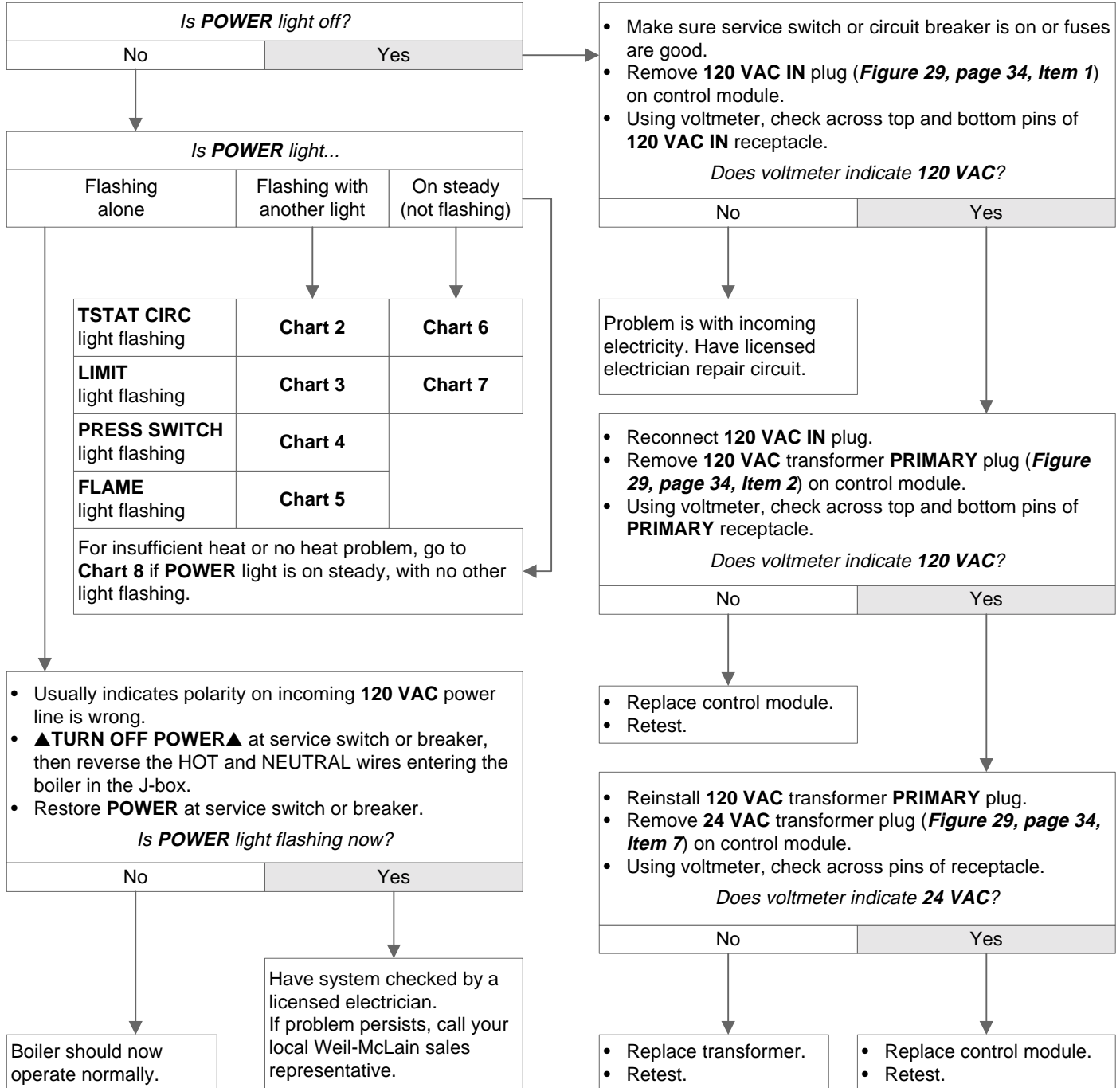

# 12d Troubleshooting — charts continued

## CHART 2 — TSTAT CIRC & POWER lights flashing

**WARNING** Electrical shock hazard — Wherever you see ▲TURN OFF POWER▲, follow the instructions. Failure to follow instructions could result in severe personl injury, death or substantial property damage.

- Check for stray voltage on the incoming thermostat wires. Disconnect the two external wires connected to the boiler thermostat wires.
- Connect a voltmeter across the two incoming wires. Close each thermostat, zone valve and relay in the external circuit one at a time and check the voltmeter reading across the wires. There should NEVER be a voltage reading. If a voltage
- does occur under any condition, check and correct the external wiring. (This is a common problem when using 3-wire zone valves.)
- Once the external thermostat circuit wiring is checked and corrected if necessary, reconnect the external thermostat circuit wires to the boiler thermostat wires and allow the boiler to cycle.

*Did you find and correct a voltage across the two external thermostat circuit wires?*

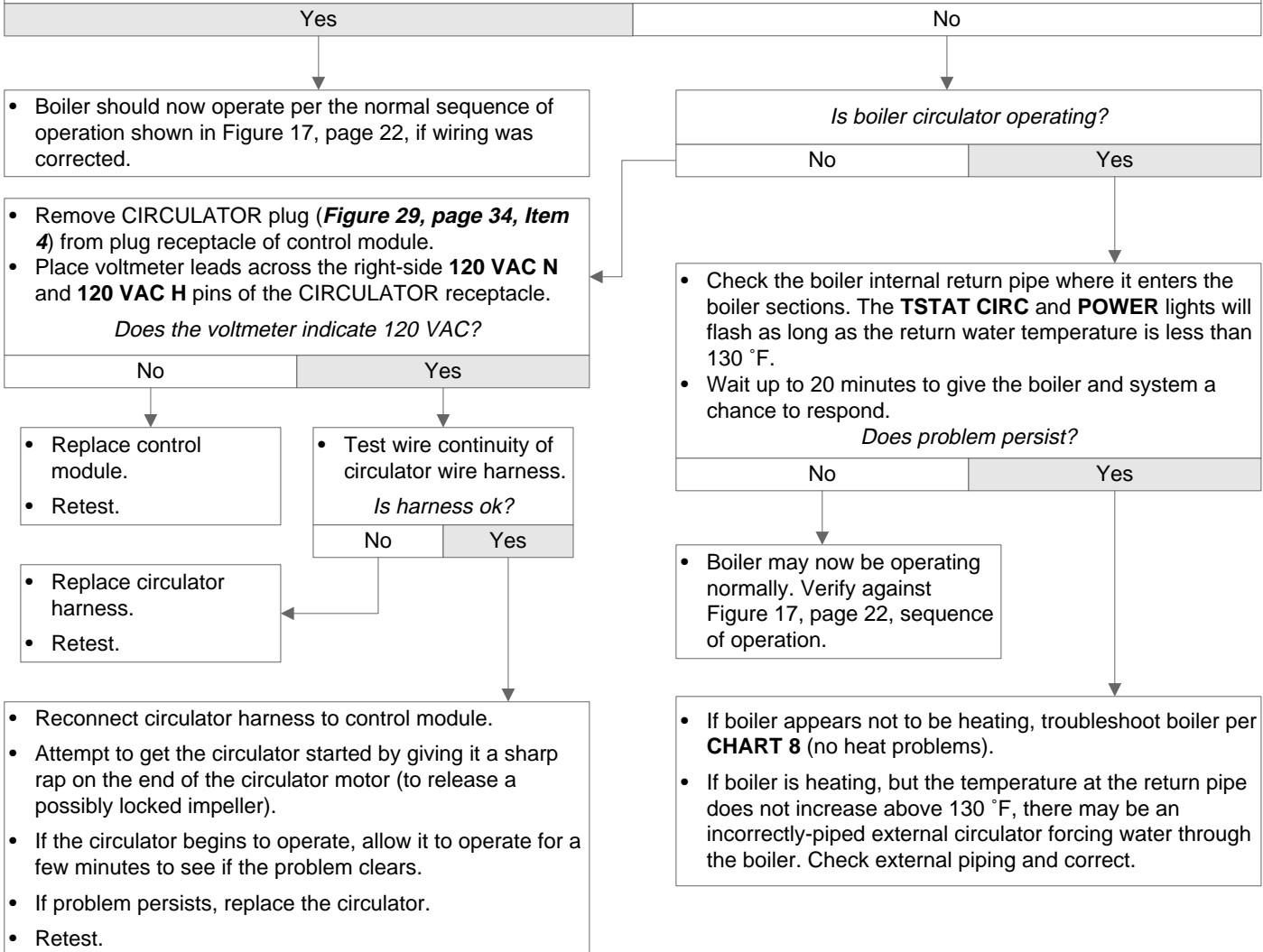

# 12d Troubleshooting — charts continued

## CHART 3 — LIMIT & POWER lights flashing

**WARNING** Electrical shock hazard — Wherever you see **▲TURN OFF POWER▲**, follow the instructions. Failure to follow instructions could result in severe personl injury, death or substantial property damage.

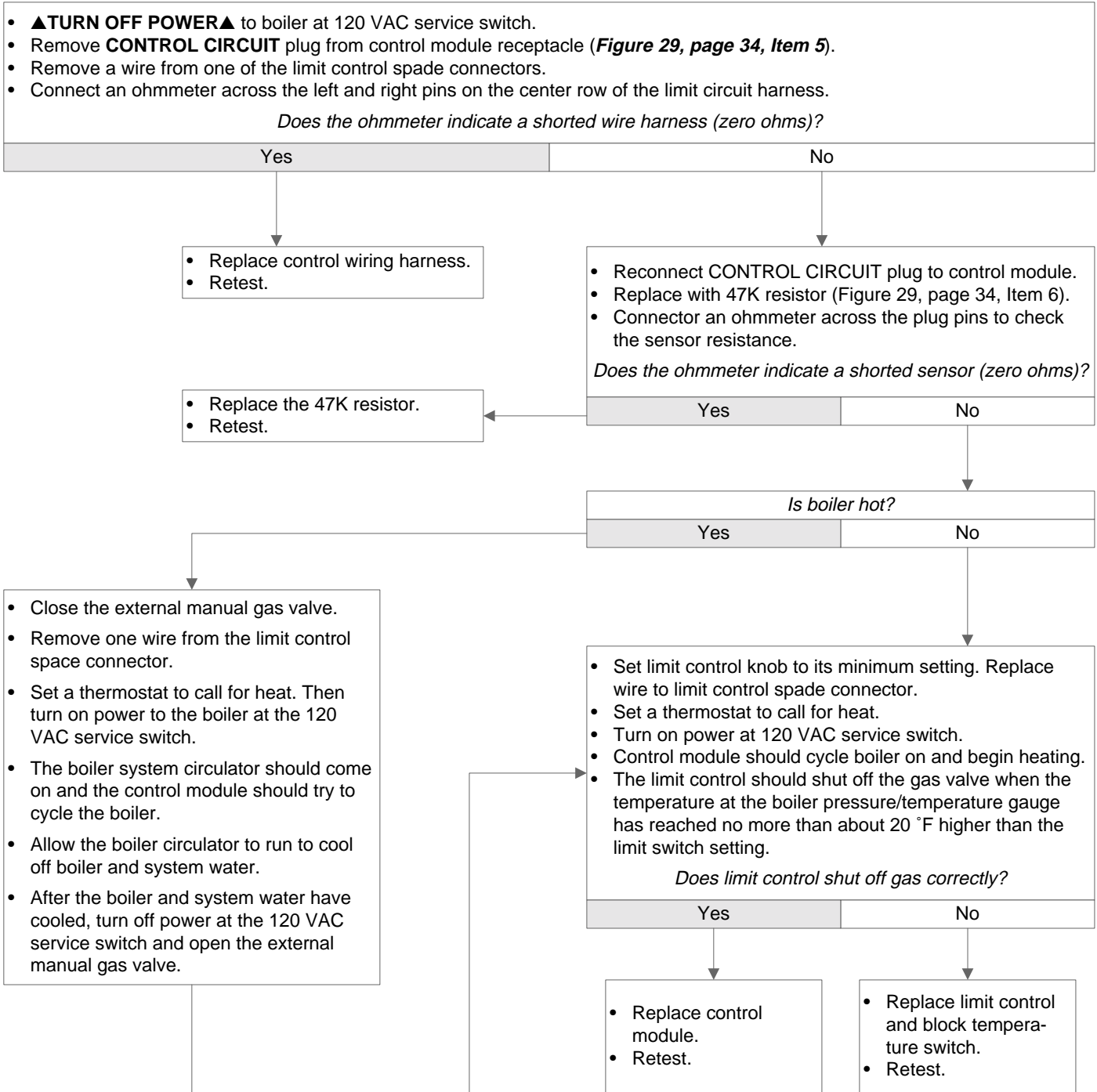

# 12d Troubleshooting — charts continued

## CHART 4 — PRES SWITCH & POWER lights flashing

**WARNING** Electrical shock hazard — Wherever you see **▲TURN OFF POWER▲**, follow the instructions. Failure to follow instructions could result in severe personal injury, death or substantial property damage.

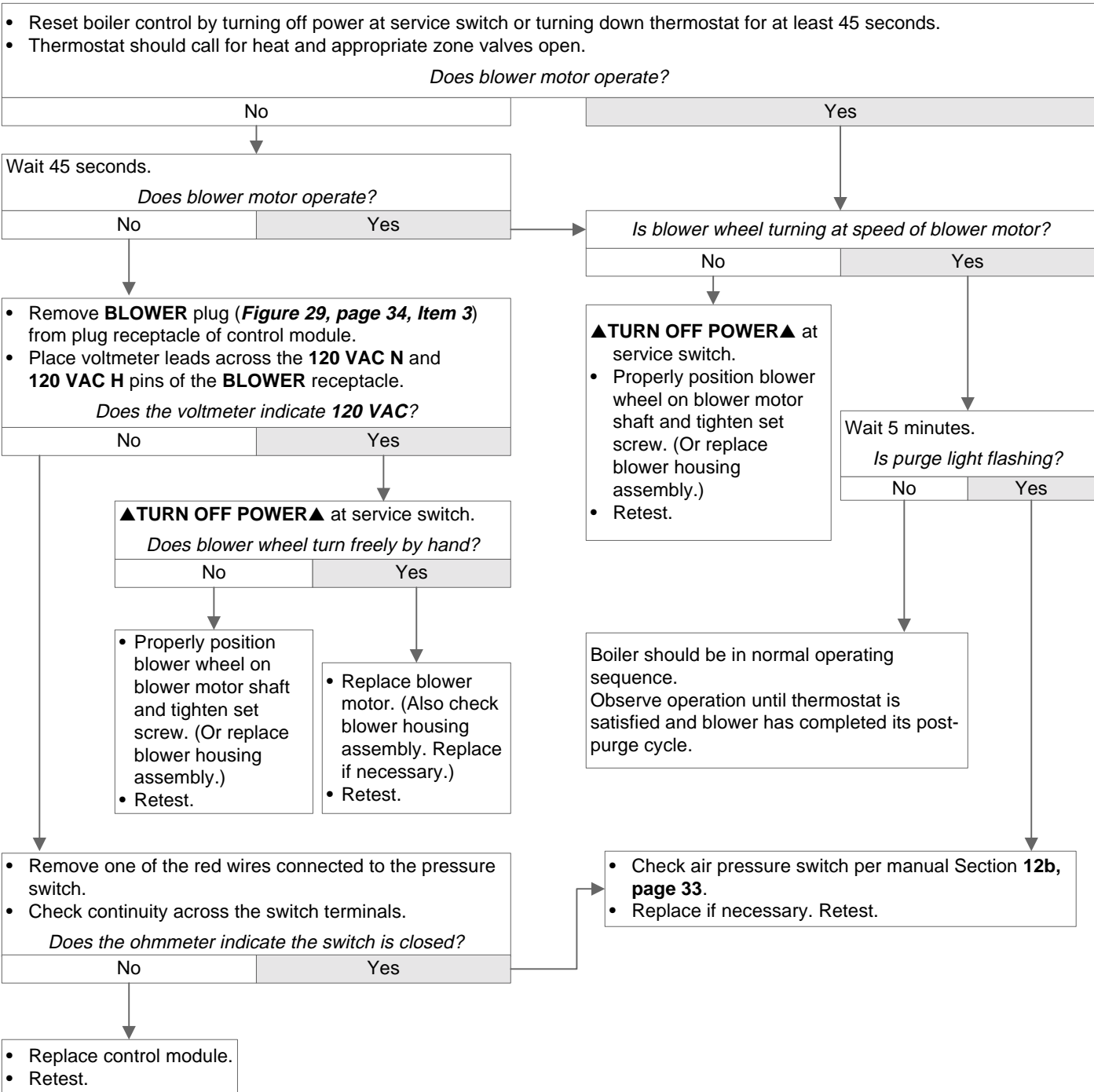

# 12d Troubleshooting — charts continued

## CHART 5 — FLAME & POWER lights flashing

**WARNING** Electrical shock hazard — Wherever you see **▲TURN OFF POWER▲**, follow the instructions. Failure to follow instructions could result in severe personal injury, death or substantial property damage.

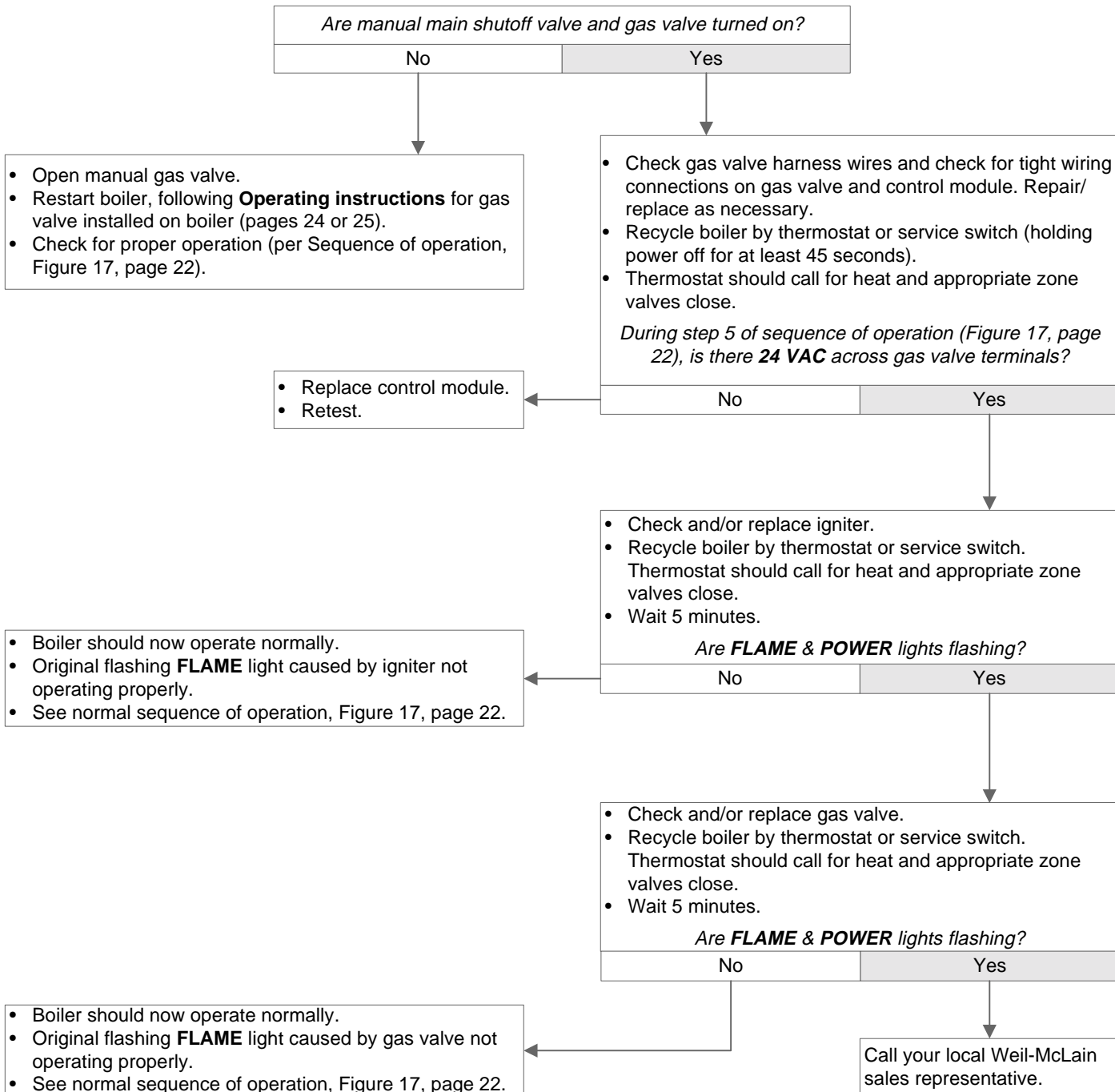

# 12d Troubleshooting — charts continued

## CHART 6 — TSTAT CIRC light flashing and POWER light on steady

**WARNING** Electrical shock hazard — Wherever you see **▲TURN OFF POWER▲**, follow the instructions. Failure to follow instructions could result in severe personl injury, death or substantial property damage.

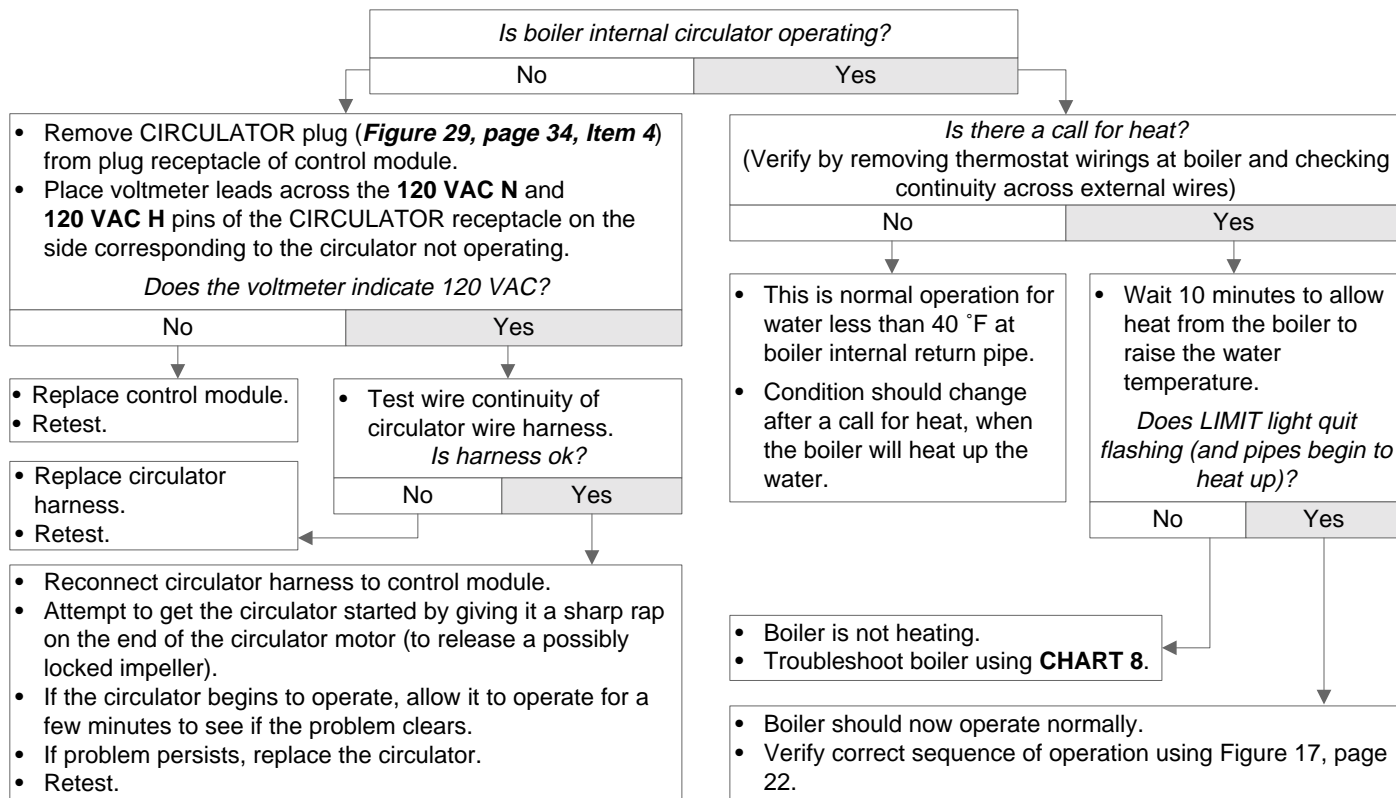

## CHART 7 — LIMIT light flashing and POWER light on steady

**WARNING** Electrical shock hazard — Wherever you see **▲TURN OFF POWER▲**, follow the instructions. Failure to follow instructions could result in severe personl injury, death or substantial property damage.

- This is not a lockout mode. The control module should only be signaling that the 47K resistor is shorted out.
- This situation is usually corrected by replacing the resistor, as described below.

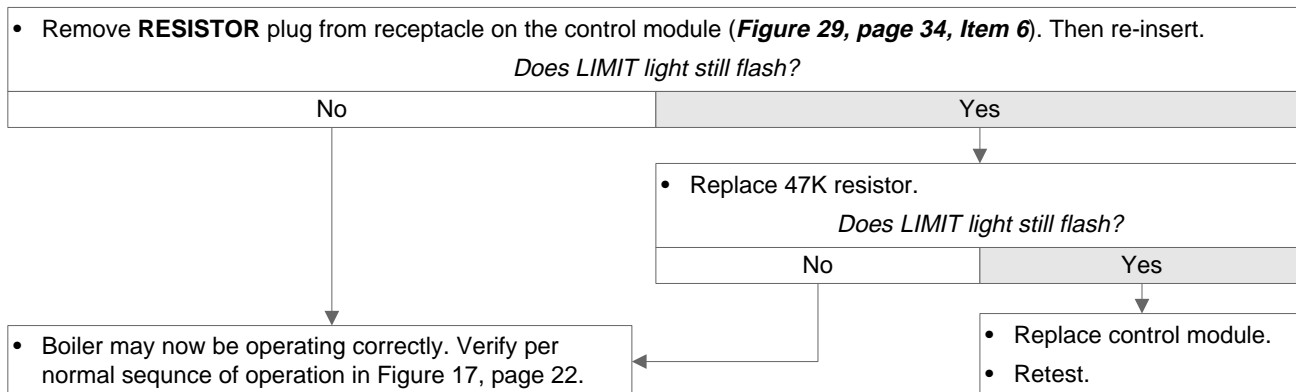

# 12d Troubleshooting — charts continued

## CHART 8 — Insufficient heat or no heat to system (POWER light on steady)

**WARNING** Electrical shock hazard — Wherever you see ▲TURN OFF POWER▲, follow the instructions. Failure to follow instructions could result in severe person injury, death or substantial property damage.

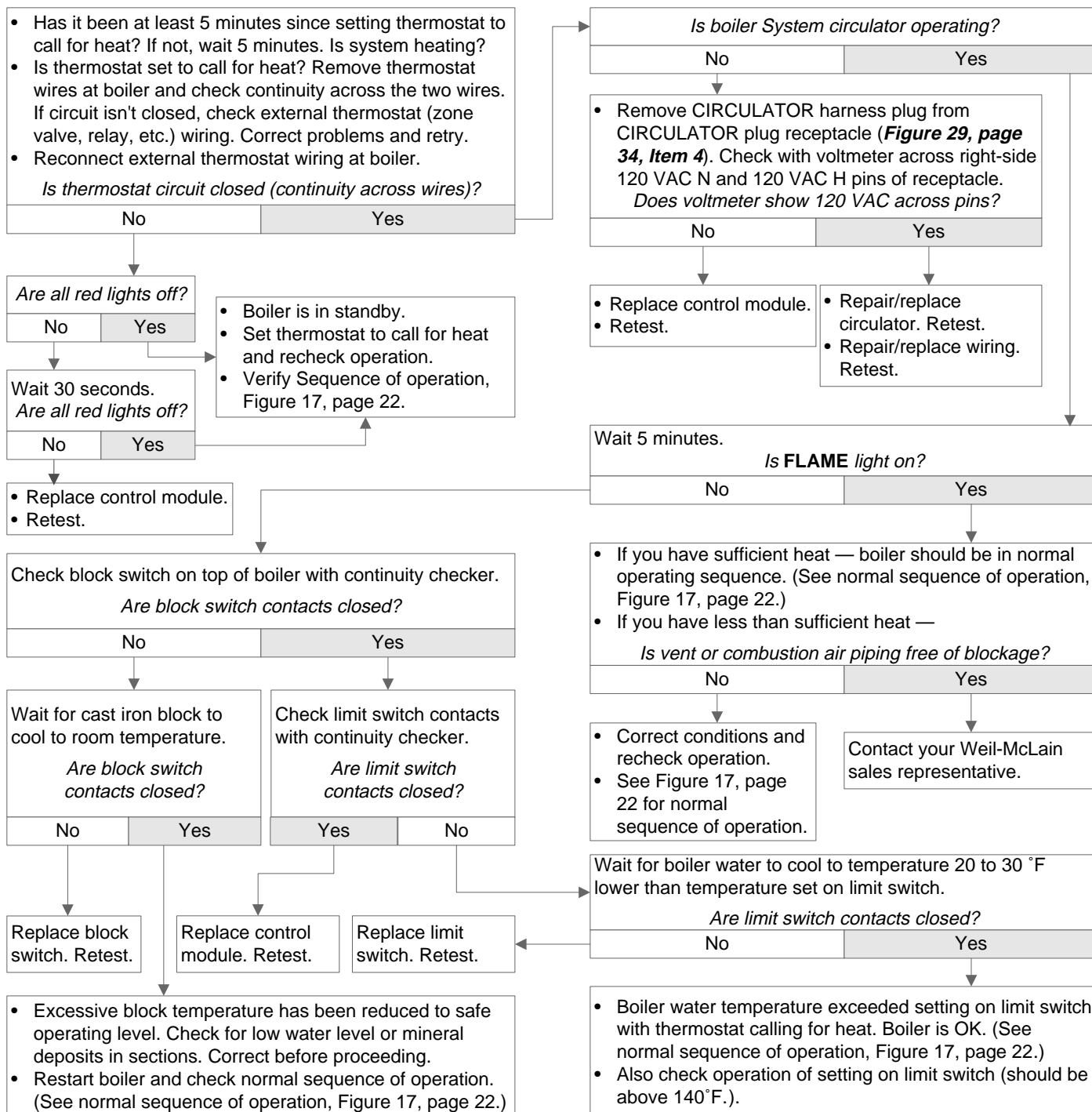

# 13a Replacement parts — base & components

Figure 30 Base assembly and component parts

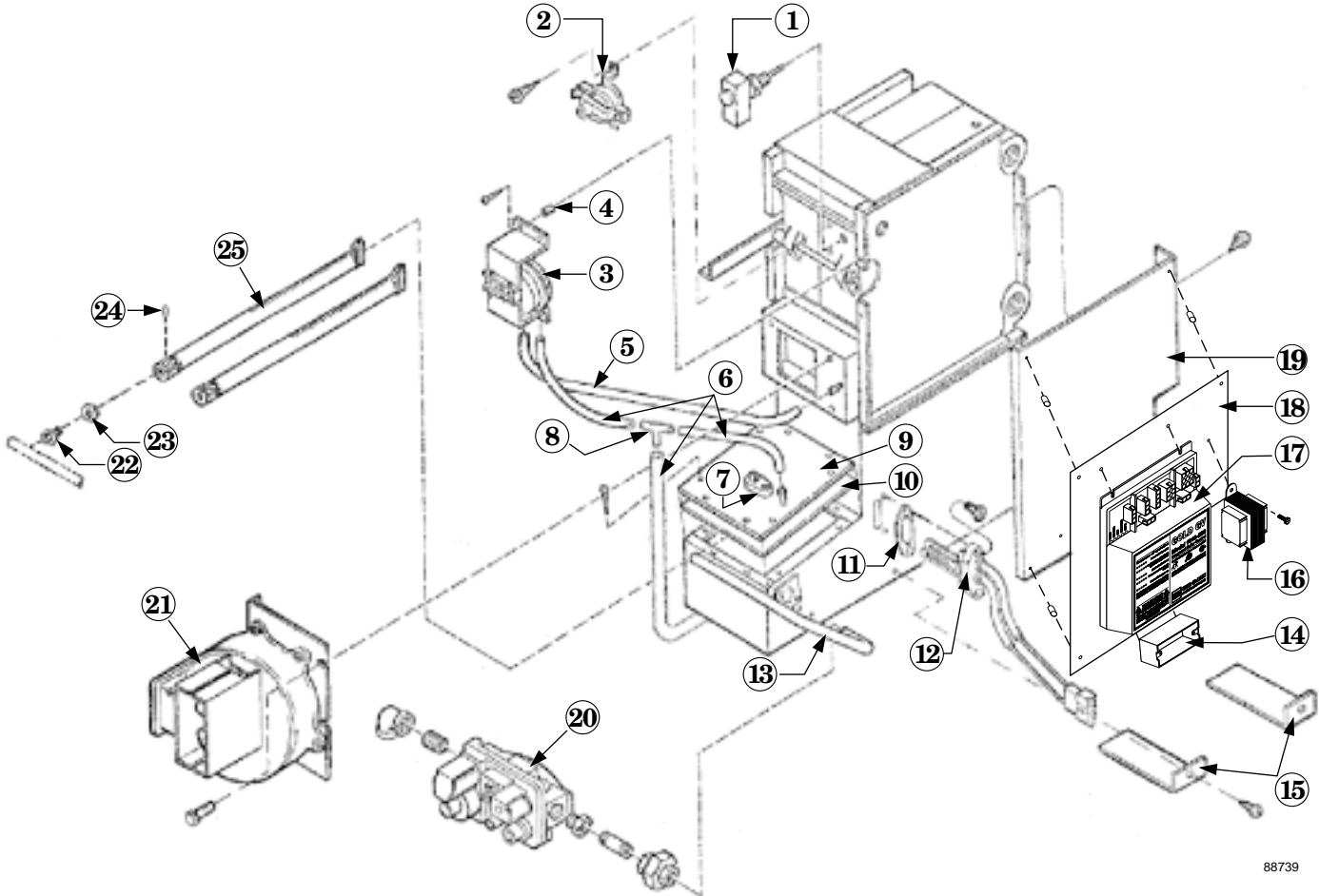

88739

Item number	Description	Manufacturer	Manufacturer's part number	Weil-McLain part number
1	Limit control with well			510-312-009
2	Block temperature switch			510-350-062
3	Pressure switch AHE-45 — .35" w.c. AHE-60 — .30" w.c.	Tridelta	FS6707-1388 FS6707-1389	511-624-530 511-624-532
4	Spacer, #10 x 1/2, steel			563-039-975
5	Silicone tubing, white 7.00"	Lyndall, Inc.	80-0694-2	590-317-632
6	Silicone tubing, red 6.00" 12.00" 14.50"	Lyndall, Inc.	80-0694-2	590-317-645 590-317-631 590-317-636
7	Rollout thermal fuse element	Microtemp	G4AM0604121C	512-050-235
8	Tee, 1/8" x 1/8" x 1/8"			obtain locally
9	Burner inlet plenum cover AHE-45 — 6" AHE-60 — 9"			450-030-779 450-030-780
10	Gasket, burner inlet plenum cover AHE-45 AHE-60			590-317-605 590-317-606
11	Gasket, ignitor			590-317-599
12	Ignitor, silicone carbide	Norton	271	511-330-145

Item number	Description	Manufacturer	Manufacturer's part number	Weil-McLain part number
13	Burner manifold AHE-45 — 7.50" AHE-60 — 10.63"			591-126-572 591-126-573
14	Junction box, 4" x 2.12"			591-804-610
15	Bottom insulation retainer			450-030-769
16	Transformer	Honeywell Product Unltd. Basler Electric	AT140B1297 4000-01V18R223 BE111640GDD	511-842-370
17	Control module	United Technologies	1013-200	511-330-088
18	Control mounting panel			450-030-829
19	Control panel			450-030-830
not shown	Wiring harness, control			591-391-902
20	Gas valve, natural gas, 1/2 x 1/2	White-Rodgers Honeywell Robertshaw	36E36-267 VR8205A2008 7200 DER	511-044-367
	Gas valve, propane gas, 1/2 x 1/2	White-Rodgers Honeywell Robertshaw	36E36-265 VR8205A2081 7200 DER	511-044-373
21	Blower motor assembly			510-312-320
22	Main burner orifice #48 hole 1.15 mm hole			560-529-018 560-529-019
23	Nut, hex jam, 1/2-20			obtain locally
24	Clip, hairpin			562-610-325
25	Main burner, stainless steel			512-200-077

# 13b Replacement parts — jacket assembly

Figure 31 Jacket assembly

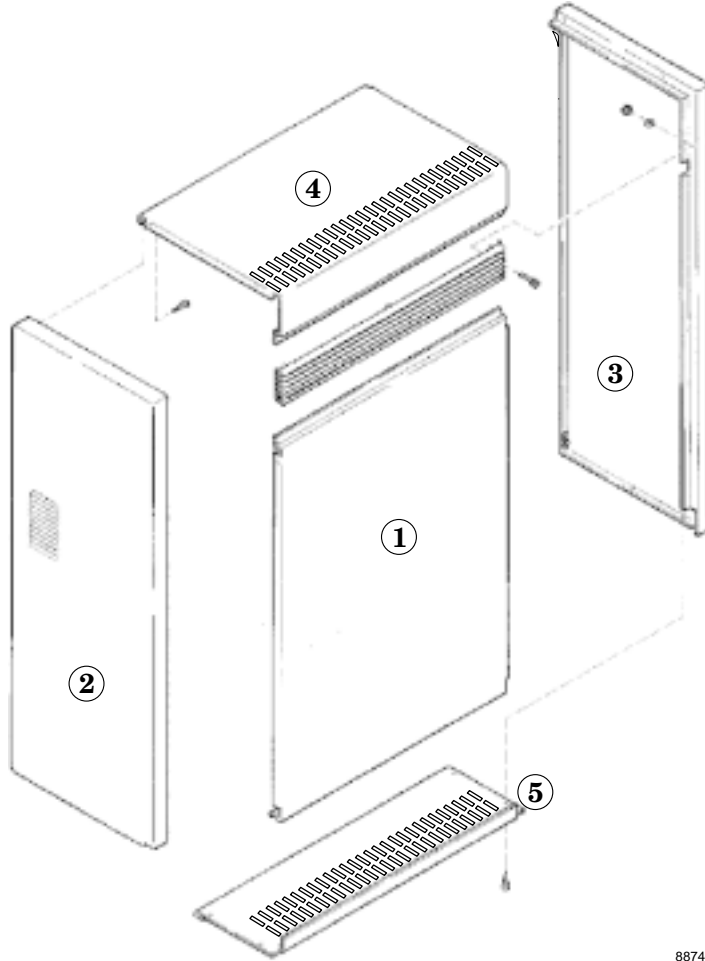

88740

Item number	Description	Boiler model number	Weil-McLain part number
1	Jacket door	All	421-400-009
2	Jacket side panel, left	AHE-45 AHE-60	421-400-010 421-400-011
3	Jacket side panel, right	AHE-45 AHE-60	421-400-012 421-400-013
4	Jacket top panel	AHE-45 AHE-60	421-400-030 421-400-035
5	Jacket bottom panel	AHE-45 AHE-60	421-400-040 421-400-045

# 13C Replacement parts — venting

Figure 32 Back and side venting mounting panel assembly

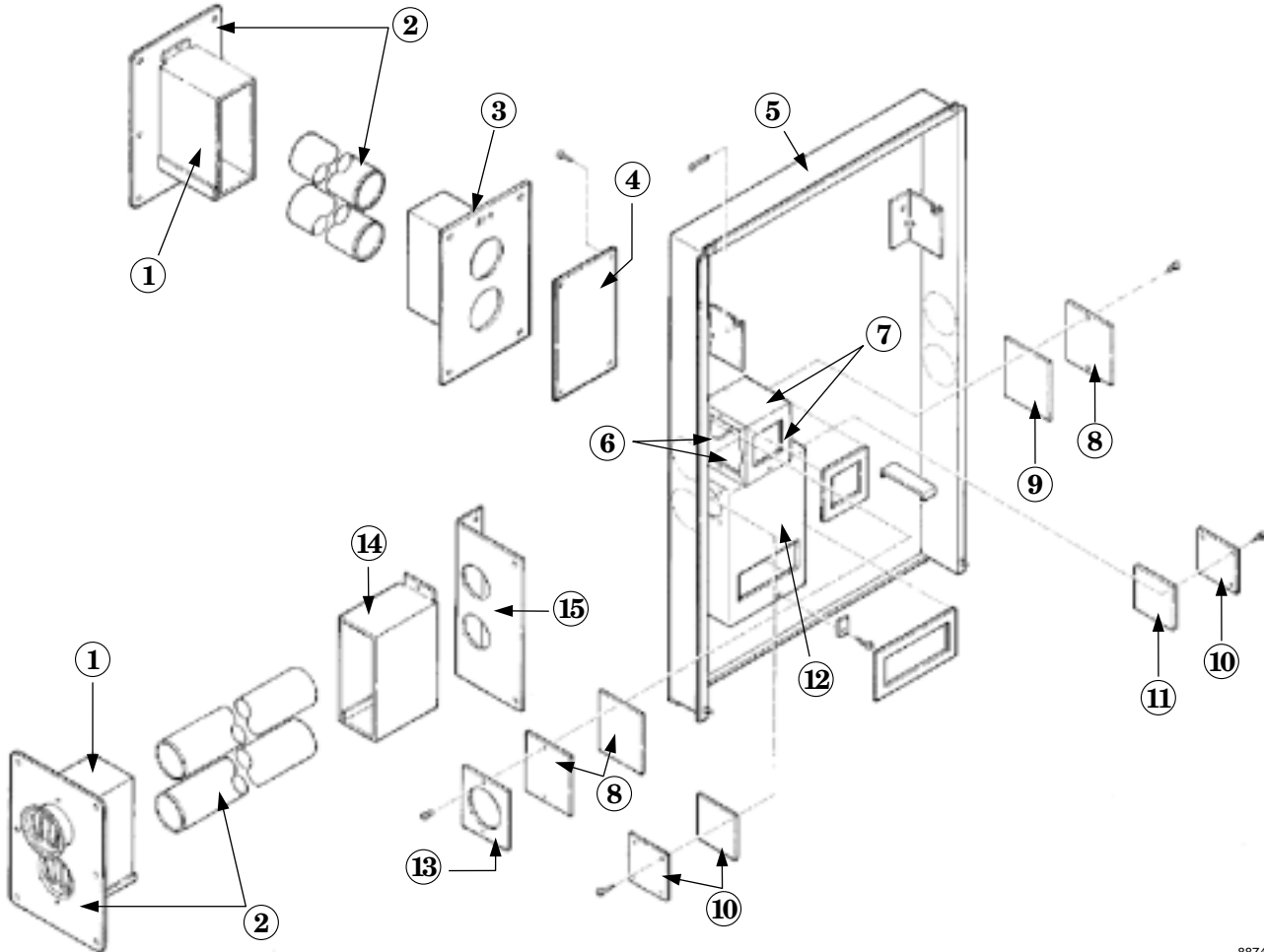

88741

Item number	Description	Weil-McLain part number		
		5-9" Wall	9-13" Wall	13-24" Wall
1	Wall sleeve, outside	450-030-754	450-030-755	450-030-800
2	Outside escutcheon and tube assembly	450-030-783	450-030-783	450-030-783
3	Inside escutcheon and sleeve, for back outlet	450-030-782	450-030-782	450-030-801
4	Mounting panel cover plate, for side venting	450-030-725	450-030-725	450-030-725
5	Mounting panel	450-030-781	450-030-781	450-030-781
6	Exhaust box, bottom and back	450-030-772	450-030-772	450-030-772
7	Exhaust box, top and front	450-030-773	450-030-773	450-030-773
8	Exhaust box cover plate	450-030-716	450-030-716	450-030-716
9	Exhaust box gasket	590-317-600	590-317-600	590-317-600
10	Air intake cover plate	450-030-713	450-030-713	450-030-713
11	Air intake gasket	590-317-601	590-317-601	590-317-601
12	Air intake box	450-030-776	450-030-776	450-030-776
13	Exhaust box cover plate with hole	450-030-739	450-030-739	450-030-739
14	Wall sleeve, inside	450-030-753	450-030-753	450-030-802
15	Inside escutcheon, for side outlet	450-030-730	450-030-730	450-030-730

# 13d Replacement parts — trim

Figure 33 Boiler trim

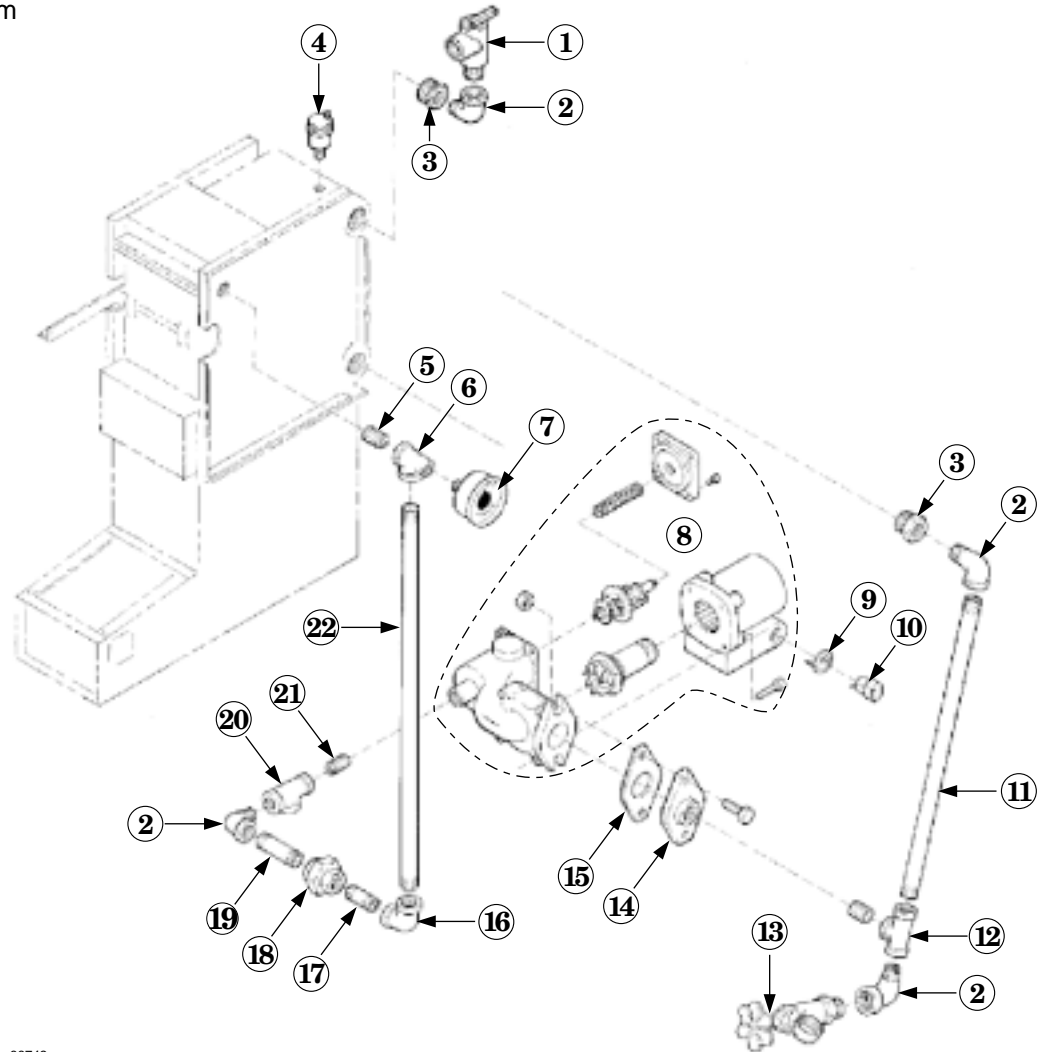

88742

Item number	Description	Manufacturer	Manufacturer's part number	Weil-McLain part number
1	Relief valve, 3/4"	Conbraco	10-407-10	511-546-923
2	Street elbow, 3/4", black			obtain locally
3	Bushing, 1 1/2" x 3/4", black, inside hex			obtain locally
4	Air vent	Maid-O-Mist Watts	66 ZV-4MI	510-148-563
5	Close nipple, black AHE-45 — 3/4" AHE-60 — 3/4" x 4 1/2"			obtain locally
6	Tee, 3/4" x 1/4" x 3/4"			obtain locally
7	Combination temperature-pressure gauge, short shank	US Gauge/ Ametek ENFM	199980 4104-2-1/2-1/4CBM	510-218-099
8	Circulator pump with mixing valve	Taco	005-RFI-2W	511-405-008
9	Strain relief bushing			obtain locally
10	Strain relief adapter			obtain locally
11	Nipple, 3/4" x 13 1/2", black			obtain locally

Item number	Description	Manufacturer	Manufacturer's part number	Weil-McLain part number
12	Tee, 3/4", black			obtain locally
13	Drain valve, 3/4"	Conbraco Hammond Matco-Norca Watts	31-606-01 710 205F04 BD-2C	511-210-423 511-246-392 511-246-392 511-246-392
14	Pump flange, 3/4"			563-910-025
15	Gasket			590-317-535
16	Elbow, 3/4", black			obtain locally
17	Nipple, 3/4" x 2 1/2", black			obtain locally
18	Union, 3/4", black			obtain locally
19	Nipple, black AHE-45 — 3/4" x 3" AHE-60 — 3/4" x 6"			obtain locally
20	Tee, 3/4" x 1/2" x 3/4", black			obtain locally
21	Close nipple, 1/2", black			obtain locally
22	Nipple, 3/4" x 22 1/2", black			obtain locally

# 14 Dimensions

Figure 34

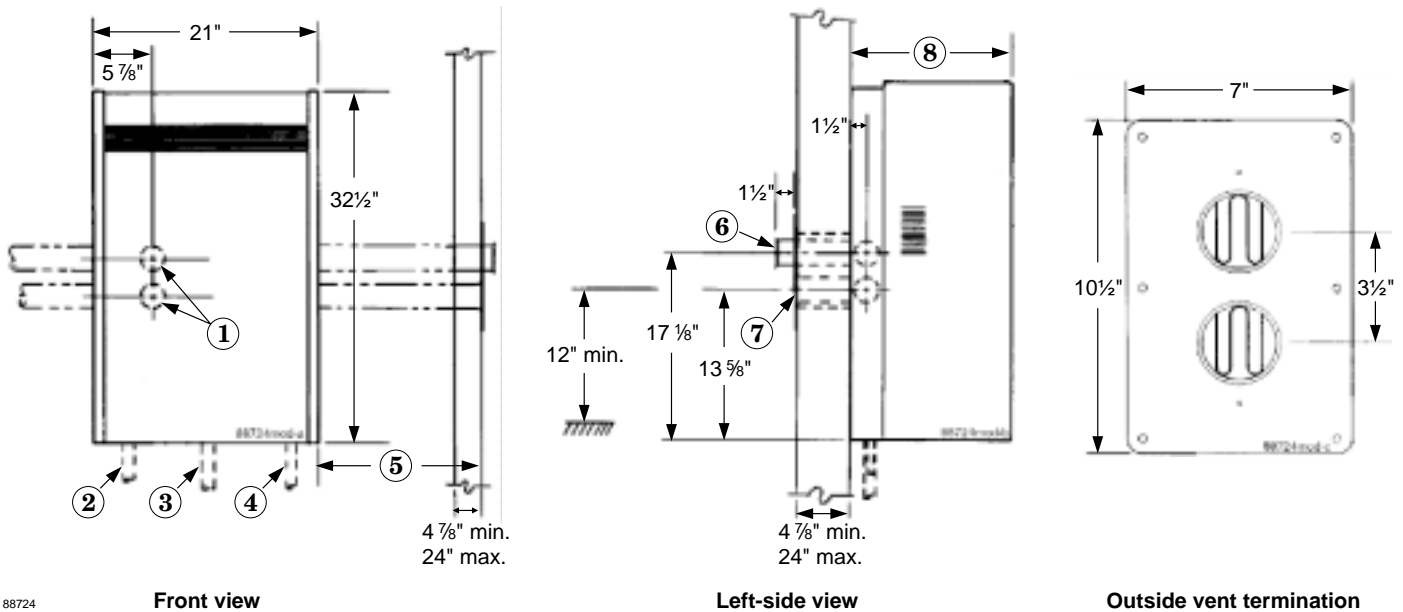

88724

Item number	Description
1	Rear vents
2	Gas supply Natural gas connection size 3/8" NPT (Gas piping from meter to boiler to be sized per local utility requirements.)
3	System supply, 3/4" NPT
4	System return, 3/4" NPT
5	See Figure 1, page 10
6	2 3/8" diameter exhaust vent
7	2 3/8" diameter intake vent
8	Boiler depth AHE-45 — 14 7/8" AHE-60 — 17 7/8"

Boiler model	Boiler crate dimensions (outside measurement, inches) (Note 1)			Approximate weight (boiler only, pounds)	
	Length	Width	Height	Shipping	Uncrated
AHE-45	36	19 1/2	24 1/2	145	132
AHE-60	36	19 1/2	24 1/2	177	166

Note 1: Boiler and components shipped in separate cartons.

# 15 Ratings



**DOE**



Boiler model number	0-2,000 feet altitude		2,000-4,500 feet altitude (Canada)		Net I=B=R ratings (Btuh)	Boiler water content (gallons)	DOE Seasonal efficiency (% AFUE)
	Input (Btuh)	DOE Heating capacity (Output) (Btuh)	Input (Btuh)	Output (Btuh)			
		(Note 1)			(Note 2)		
<b>AHE-45</b>	45,000	38,000	40,500	34,500	33,000	1.15	85.3
<b>AHE-60</b>	60,000	51,000	54,000	46,000	44,000	1.73	85.5

## Notes

1. Based on standard test procedures prescribed by the United States Department of Energy.
2. Net I=B=R ratings are based on net installed radiation of sufficient quantity for the requirements of the building and nothing need be added for normal piping and pickup. Ratings are based on a piping and pickup factory of 1.15. An Additional allowance should be made for unusual piping and pickup loads.

**AHE boilers tested at 50 PSI working pressure.**

# Handling ceramic fiber and fiberglass materials

## REMOVAL OF COMBUSTION CHAMBER LINING OR BASE PANELS

**WARNING**

The combustion chamber lining or base insulation panels in this product contain ceramic fiber materials. Ceramic fibers can be converted to cristobalite in very high temperature applications. The International Agency for Research on Cancer (IARC) has concluded, "Crystalline silica inhaled in the form of quartz or cristobalite from occupational sources is carcinogenic to humans (Group 1).":

- Avoid breathing dust and contact with skin and eyes.
  - Use NIOSH certified dust respirator (N95). This type of respirator is based on the OSHA requirements for cristobalite at the time this document was written. Other types of respirators may be needed depending on the job site conditions. Current NIOSH recommendations can be found on the NIOSH web site at <http://www.cdc.gov/niosh/homepage.html>. NIOSH approved respirators, manufacturers, and phone numbers are also listed on this web site.
  - Wear long-sleeved, loose fitting clothing, gloves, and eye protection.
- Apply enough water to the combustion chamber lining or base insulation to prevent airborne dust.
- Remove combustion chamber lining or base insulation from the boiler and place it in a plastic bag for disposal.
- Wash potentially contaminated clothes separately from other clothing. Rinse clothes washer thoroughly.

**NIOSH stated First Aid.**

- Eye: Irrigate immediately
- Breathing: Fresh air.

## REMOVAL OF FIBERGLASS WOOL — OR —

## INSTALLATION OF FIBERGLASS WOOL, COMBUSTION CHAMBER LINING OR BASE PANELS:

**WARNING**

This product contains fiberglass jacket insulation and ceramic fiber materials in combustion chamber lining or base panels in gas fired products. Airborne fibers from these materials have been listed by the State of California as a possible cause of cancer through inhalation.

- Avoid breathing dust and contact with skin and eyes.
  - Use NIOSH certified dust respirator (N95). This type of respirator is based on the OSHA requirements for fiberglass wool at the time this document was written. Other types of respirators may be needed depending on the job site conditions. Current NIOSH recommendations can be found on the NIOSH web site at <http://www.cdc.gov/niosh/homepage.html>. NIOSH approved respirators, manufacturers, and phone numbers are also listed on this web site.
  - Wear long-sleeved, loose fitting clothing, gloves, and eye protection.
- Operations such as sawing, blowing, tear out, and spraying may generate airborne fiber concentration requiring additional protection.
- Wash potentially contaminated clothes separately from other clothing. Rinse clothes washer thoroughly.

**NIOSH stated First Aid.**

- Eye: Irrigate immediately
- Breathing: Fresh air.



**WEIL-McLAIN**  
A United Dominion Company

Weil-McLain  
500 Blaine Street  
Michigan City, IN 46360-2388  
<http://www.weil-mclain.com>