



## Videojet 4811 Autoloader

### Shuttle Bypass High Capacity Autoloader

- **Rapid return on investment**
- **Increase feeder capacity**
- **Reduce labor within the work cell**
- **Feeder sort control option**
- **Integrates easily with Cheshire® Model 7000 base**

The Videojet 4811 autoloader feeds a wide range of products with superior product handling. You can increase your production on shuttle bases with this high capacity autoloader that integrates with any continuous application.

The Videojet 4811 is designed to eliminate limitations on range of feedable products and stack heights. This system shingles material on a high capacity conveyor that cascades into the feeder hopper. By combining the system's vibrating back wedge and Dynamic Rotation Technology®, you can increase your productivity 3-fold. Standard features of the 4811 include patented Dynamic Rotation Technology®, vibrating back wedge, 6-foot infeed conveyor, external run interface and casters. An optional 9-foot infeed conveyor is also available.



**Shown with Cheshire® Model 7000 base (purchased separately)**

### How does the Videojet 4811 work?

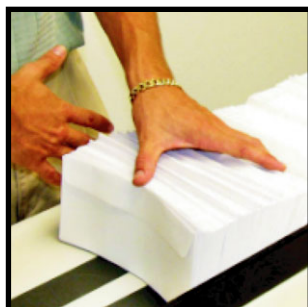

**Product is loaded onto the Videojet 4811 High Capacity Autoloader**

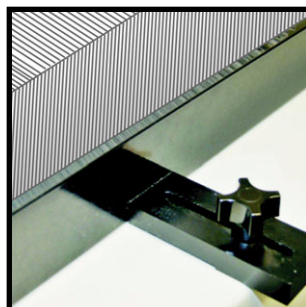

**Adjustable guide keeps product square**

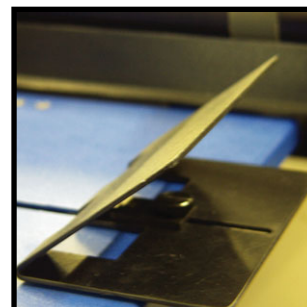

**The jogging wedge pre-shingles product for consistent separation**

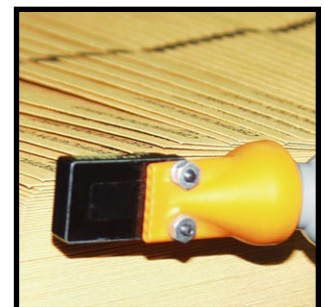

**Adjustable photo eye provides optimal pile height in hopper**

The 4811 autoloader is ideal for high speed feeding applications for ink jet printing, tabbing, labeling and many other continuous feed situations. The Cheshire® Model 7000 base features an innovative vacuum shuttle feeder that improves product feeding and reduces vibration, even at high speeds. This base can run a wide array of media sizes at speeds up to 30,000 pieces per hour with a standard model.

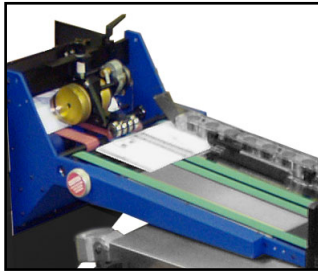

**Infeed Alignment Station**

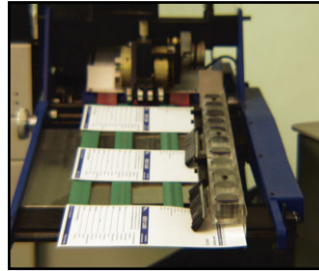

**Registration side guides squares product prior to ink jetting**

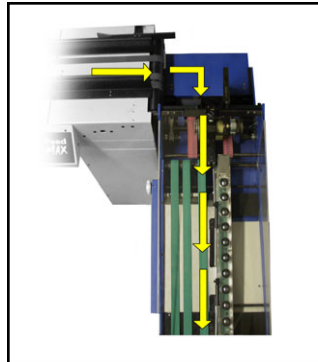

**90 degree configuration**

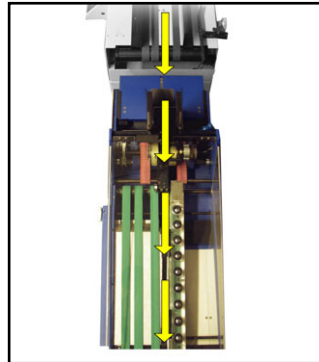

**Straight configuration**

## Videojet TotalSource® Service

The **TotalSource** program is the finest and most complete technical support system in the business. These services include everything from expert applications assistance, operator training and a full spectrum of maintenance services. The **TotalSource** program ensures total customer satisfaction. **Support when you need it**



## Specifications

### Speed

Variable up to 500 ft/min. (152 m/min.)

### Maximum Product Size

11.5" wide x 13.0" long (29 cm x 33 cm)

### Minimum Product Size

3.25" wide x 5.0" long (7.6 cm x 13 cm)

### Maximum Product Thickness

0.625" (15.9 mm)

### Minimum Product Thickness

0.004" (0.1 mm)

### Materials

Envelopes, flats, self-mailers, postcards, single sheets, magazines, booklets, pamphlets, chipboard, plastics (all materials are product dependent)

### Feeder Capacity

2,000 #10 envelopes

### Humidity Range

15% to 90% relative humidity

### Power Requirements

120 VAC / 240 VAC

### Dimensions

Footprint w/6-foot (183 cm) infeed - 35.0" high x 16.0" wide x 85.0" long (89 cm x 41 cm x 216 cm)

### Approximate Weight

500 lbs. (227 kgs)

### Separator

Dynamic Rotation Technology®

### Drive Motor

Variable DC

### Options

9-foot (2.75 m) length infeed conveyor is available

© 2006 Videojet Technologies Inc. - All rights reserved. Videojet Technologies Inc.'s policy is one of continued product improvement. We reserve the right to alter design and/or specifications without notice. Videojet, Cheshire and TotalSource are registered trademarks of Videojet Technologies Inc. Dynamic Rotation Technology is a registered trademark of Sure-Feed Engineering, Inc.

**CERTIFIED  
ISO 9001  
DOCUMENTED QUALITY**



**800-843-3610 • www.videojet.com • info@videojet.com**

Videojet Technologies Inc. • 1500 Mittel Boulevard

Wood Dale IL • 60191-1073 • USA

Phone: 630-860-7300 • Fax: 630-616-3623

**Packaging - Processing  
Bid on Equipment**

**1-847-854-8577**

**www.bid-on-equipment.com**