

Large Character Ink Jet Printing

- Higher resolution – up to 40 dpi
- Flexibility to print on porous and non-porous materials
- Superior throw distance for reliable printing in all industrial environments
- Print height flexibility from slant technology for one or two lines of print between 0.1 and 2.4 inches in height per printhead
- Easy to use color touch screen with graphical interface
- Control up to 8 printheads from one interface

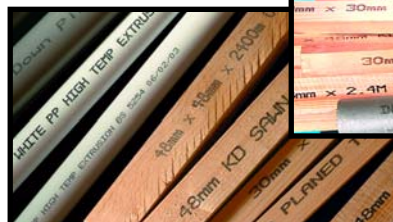

Versatile Large Character Printing

The Marsh® 320Si Large Character Ink Jet Printer

The Marsh 320Si large character printer combines increased throw distance and precision drop placement with higher speeds, to deliver reliable coding and printing solutions for a wide variety of industrial applications. The Marsh 320Si system features an advanced touch-screen graphical user interface and modular and scalable hardware/software design for maximum flexibility.

Simple, easy-to-use graphical user interface



Touch-screen controller with 7.5" or 10.4" (19 or 26.4 cm) display

Printer with integrated electronics and pump system



16-dot, revolutionary micro-valve printhead with slant head technology

Advanced Print Head Technology

The Marsh 320Si printer's new printheads combine advanced micro-valve and slant head technologies to provide higher resolutions of up to 40 dpi, precision drop placement and superior throw distance. These printheads are also rated to run at 187 feet per minute (57 m/min.) at 40 dpi resolution. The precision manufactured micro-valves are designed to run with both water-based and fast-dry solvent-based inks, providing maximum flexibility. The system is rated at IP54 to withstand extreme environmental conditions in a variety of customer applications. Slant head technology offers the ultimate in coding flexibility with print heights available from 0.1 inch to 2.4 inches (2.5 mm to 60 mm).

Slant Technology

The Marsh 320Si printer can print characters using fonts which are based on 7, 9, 12, 15 and 16 drops. The slant technology also enables such characters to be printed in messages which are between 0.1 inch and 2.4 inches (2.5 and 60 mm) in height. The micro-valves in this printer enable the widest range of print heights, allowing for both primary and secondary packaging to be printed from one system.

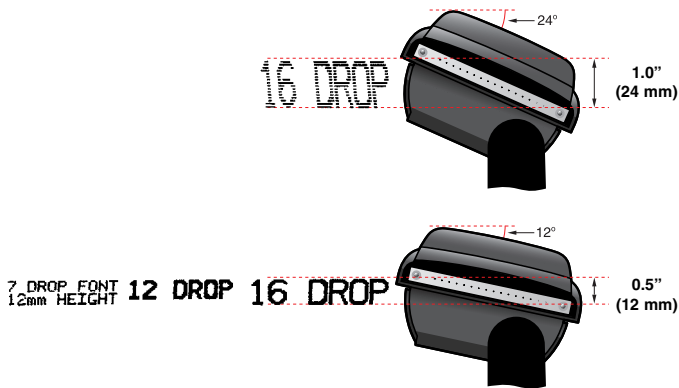

Throw Distance

The proprietary valves in the Marsh 320Si printhead operate at a higher frequency than those in printers with traditional technology, and the ink is output at a much higher speed. This makes the printer more robust in changes to throw distance, so it can print messages at throw distances of up to 1.2 inches (30 mm) or more, depending on line speed and substrate. Traditional technologies can handle throw distances of no more than 0.12 to 0.16 inches (3-4 mm) before print quality degrades.

This insensitivity to throw distance enables the Marsh 320Si printer to operate in applications where the substrate is irregular and when physical constraints limit close access to it.

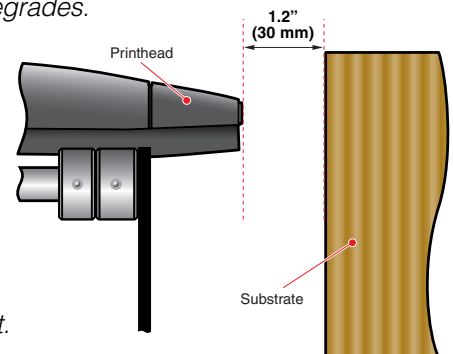

Modular, Scalable Software

The Marsh 320Si printer is designed to give you the most flexibility to mix and match both hardware and software options. The controller is pre-programmed with multiple languages to allow individual users to pick their language. Multiple security levels can be programmed by users to have a variety of different access levels. Built-in on-line help and the graphical user interface reduces training time and maximizes uptime.

Typical Applications

The Marsh 320Si system's higher print resolution, increased throw distance and variable print height enhance its performance significantly beyond the traditional applications of valvejet printers.

The Marsh 320Si printer can be used to print on:

- Corrugated cases and clay-coated cartons
- Plastic/paper sacks for minerals and cement packaging
- Plastic/metal drums for chemical and petroleum products
- Rice, corn, wheat, and other food grain and seed packages
- Products in piping and conduit extrusion and processing
- Flat rolled or coiled steel and metal products
- Carpets and other woven materials

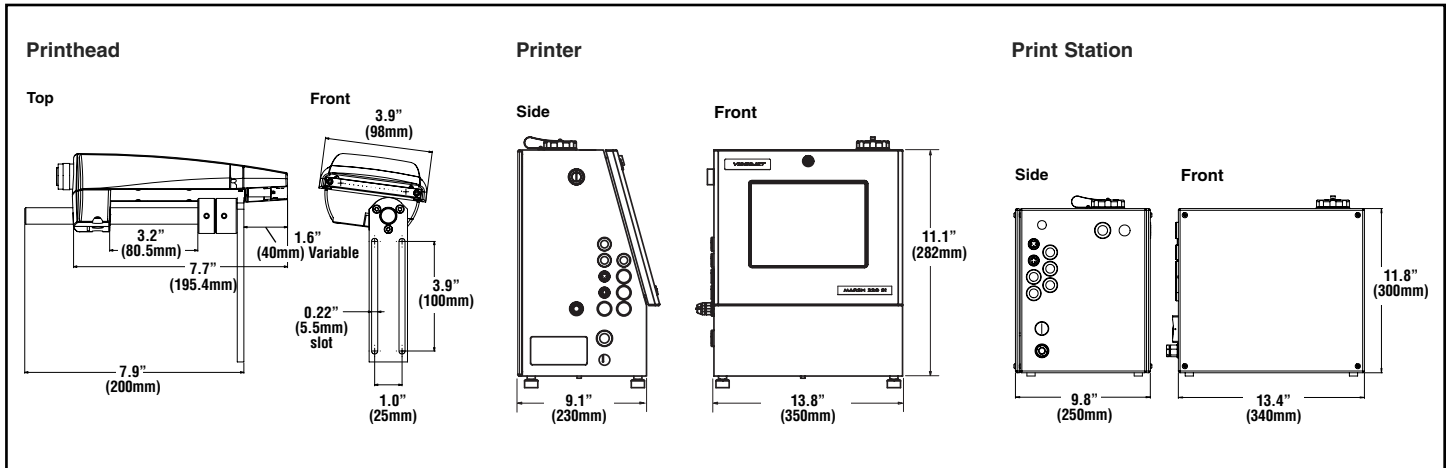

Specifications

System Components

Printer

- IP-54 stainless steel industrial enclosure
- 7.5" (19 cm) or 10.4" (26.4 cm) touch-screen interface
- Supports 2 printheads per printer; capable of multi-tasking
- Ethernet networking connection

Print stations (optional)

- IP-54 stainless steel industrial enclosure
- 2 printheads per station
- Photocell and shaft encoder connections
- 2 litre capacity pump driven ink system
- Up to 3 print stations per printer
- Up to 8 printheads via single interface
- Up to 4 production lines via single interface

Printhead

- Print resolution up to 40dpi
- Maximum line speed at optimum resolution 187 feet/min. (57 m/min.)
- Optimal throw distance 0.4" (10 mm); expandable up to 1.2" (30 mm)
- 10-foot (3 m) umbilical length

Standard software

- Standard twin-line printing
- 4 font size choices: 7, 9, 12, 15 and 16 dot high (19, 24 and 32 dot high via electronic head stitching)
- Regular and Julian dating
- Regular and military time
- Counters: consecutive counting (incrementing & decrementing)
- Warehouse barcodes

Electrical requirements

- Supply voltage: 110-230 VAC +/-15%
- Frequency: 50 Hz to 60 Hz
- Controller power consumption: 60 VA
- Print station power consumption: 150VA

PC Software Requirements *(only needed when interfacing)*

Windows® 95, 98, NT, 2000, XP, XP Pro

Printhead Orientation

- Distance to print surface - no greater than 1.2" (30 mm)
- Firing directions - 360°
- Mounting - conveyor

Messages

Alphanumeric lines

Customer logos
Mixed font messages
Remote inserts

Print Heights

0.1" to 2.4" (2.5 mm to 60 mm)

Storage

80 MB for message, font and graphics

Ink

Colors

Black, blue and red

Capacity

2 liter ink reservoir; 1-liter ink bottle

Substrates

Water-based and fast-dry solvent-based for both porous and non-porous substrates

Environmental Limits

Operating temperature

41°F to 113°F (5°C to 45°C)

Relative humidity

0 to 90% non-condensing

Ink consumption

Typical ink consumption based on font and average drop size (0.6 mm drop size)

Character matrix	Ink Consumption characters per liter (millions)
12 x 10	6.8
16 x 11	4.6



© 2006 Videojet Technologies Inc. – All rights reserved. Videojet Technologies Inc.'s policy is one of continued product improvement. We reserve the right to alter design and/or specifications without notice. Videojet and Marsh are registered trademarks of Videojet Technologies Inc. Windows is a registered trademark of Microsoft Corporation.



800-843-3610 • www.videojet.com • info@videojet.com

Videojet Technologies Inc. • 1500 Mittel Boulevard
Wood Dale IL • 60191-1073 • USA
Phone: 630-860-7300 • Fax: 630-616-3623

For additional information, contact your local Marsh product distributor at:

Packaging - Processing
Bid on Equipment

1-847-854-8577

www.bid-on-equipment.com