

We Build Confidence... *In Label Printing and Application*

The modular Labeljet 262 offers over 80 label printer application configurations, satisfying all industrial requirements.

- ***Label curved surfaces, recesses or around corners***
- ***High quality thermal transfer for high resolution crisp bar codes and text***
- ***Built to last for heavy-duty, continuous use in the most rugged industrial environments***

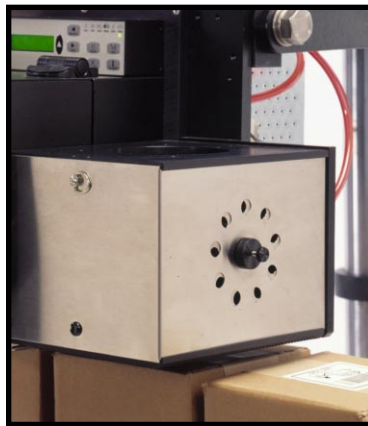

Tamp-on module option

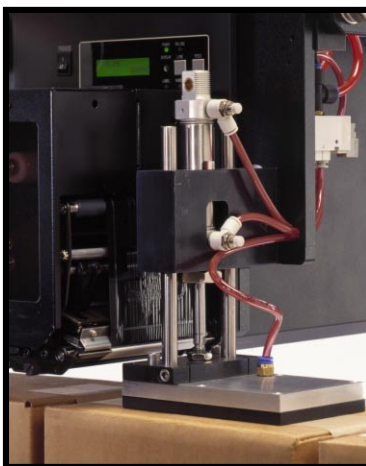

Blow-on module option

Get confident. Contact us today.

We Build Confidence...

Standard Label Application Modules Available:

	Label Width		Label Length		Stroke/Reach
	Min	Max	Min	Max	
Airjet	1.0 in. 25 mm	5.2 in. 130 mm	1.0 in. 25 mm	5.2 in. 130 mm	-
Airjet	1.0 in. 25 mm	5.2 in. 130 mm	1.0 in. 25 mm	9.1 in. 230 mm	-
Airjet	1.0 in. 25 mm	7.1 in. 180 mm	1.0 in. 25 mm	7.2 in. 180 mm	-
Airjet	1.0 in. 25 mm	7.1 in. 180 mm	1.0 in. 25 mm	9.1 in. 230 mm	-
Tamp	0.8 in. 20 mm				2.0 in. 50 mm
Tamp	0.8 in. 20 mm	Depends on label size			6.3 in. 160 mm
Tamp	0.8 in. 20 mm				11.8 in. 300 mm
Tamp A5	2.4 in. 60 mm	7.3 in. 185 mm	4.0 in. 100 mm	8.3 in. 210 mm	19.7 in. 500 mm
Tamp A5	2.4/ in. 60 mm	7.3 in. 185 mm	4.0 in. 100 mm	8.3 in. 210 mm	31.5 in. 800 mm

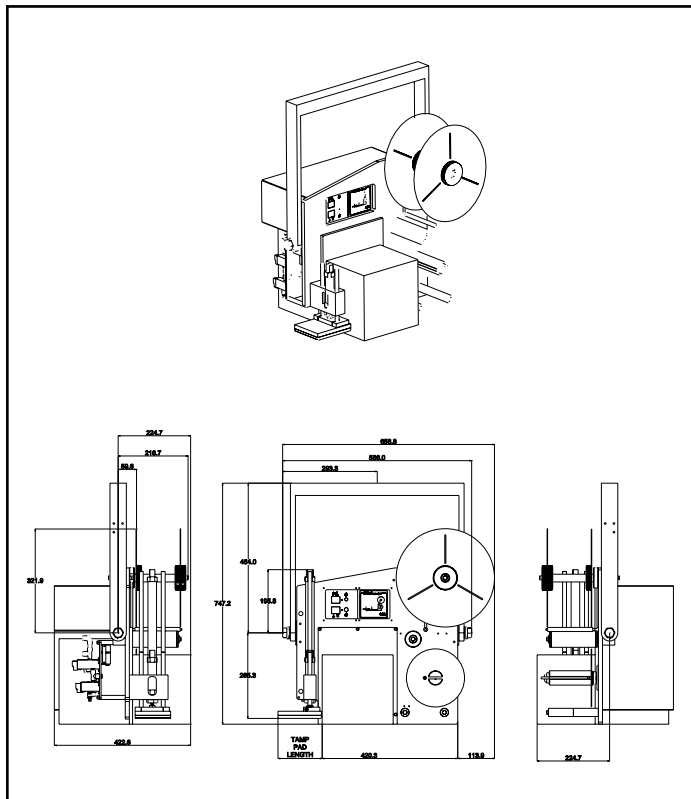

Specifications

Standard Features:

- Choice of OEM print units; Sato-, Zebra- and other compatible print engines
- Application modules for side, top, bottom, angles, recesses and corners
- Downtime reduced with alarm options, e.g. low label and/or ribbon alarm (status controls)
- Easy integration with other equipment
- Left or right-handed versions
- Accuracy $\pm 0.04"$ (1 mm), depending on application module and label size

Options:

- Corner wrap, etc.
- Swingarm tamp
- Support stand
- Alarm beacon
- Tamp position sensor
- Vacuum control modules
- BluePrint label creation and system integration software

Label Roll Size:

- 11.8" (300 mm) outside diameter, wound on 3" (76 mm) inside diameter core
- Optional 15.7" (400 mm) unwind

Label Style:

- Diecut, waste removed, outside wound with 0.12" (3 mm) gap (minimum) in running direction

Operator Controls:

- Product delay, label apply dwell, jog reset

Electrical Requirements:

- 115/220/240 Vac 50/60Hz single phase at up to 300W max

Weight:

- Approx. 77.4 lbs. (35 kg), dependent on machine configuration

Compressed Air:

- Clean, dry air at 5.6 bar consumption between 5.3 to 127.2 quarts per minute (5 liters to 120 liters/min.), dependent upon application method and rate

Interfaces:

- Depending on OEM printer configuration, e.g. parallel, high-speed parallel, RS 232 serial, high-speed serial, RS 422, Ethernet

Standard Label Application Modules:

- Airjet blow: (130x180, 180x180, 130x230, 180x230 mm (WxL))
- Tamp (50 mm 160 mm, 300 mm stroke-length)

Approvals:

CE

© 2003 Videojet Technologies Inc. – All rights reserved. Videojet Technologies Inc.'s policy is one of continued product improvement. We reserve the right to alter design and/or specifications without notice. Labeljet is a trademark and Videojet is a registered trademark of Videojet Technologies Inc.



800-843-3610 • www.videojet.com • info@videojet.com

Videojet Technologies Inc. • 1500 Mittel Boulevard

Wood Dale IL • 60191-1073 • USA

Phone: 630-860-7300 • Fax: 630-616-3623

Packaging - Processing
Bid on Equipment

1-847-854-8577

www.bid-on-equipment.com