

# Urschel® Model GRL

## Straight or Crinkle Strip Cutter

Packaging - Processing  
**Bid on Equipment**  
1-847-683-7720  
[www.bid-on-equipment.com](http://www.bid-on-equipment.com)



### SPECIFICATIONS

Length: ..... 59.25" (1505 mm)  
Width: ..... 63.38" (1610 mm)  
Height: ..... 53.24" (1352 mm)  
Net Weight: ..... 906 lb (411 kg)  
Motor: ..... 2 HP (1.5 kW)

### APPLICATIONS

The Urschel® Model GRL is designed specifically for strip cutting plain and crinkle cut potato strips. Transverse fracturing and feathered edges of french fry pieces are minimized and longer cuts are produced with greatly reduced scrap. The machine features continuous operation for uninterrupted production, and simplified design for easy cleanup and maintenance.

Maximum product infeed is 9" (229 mm) in length.

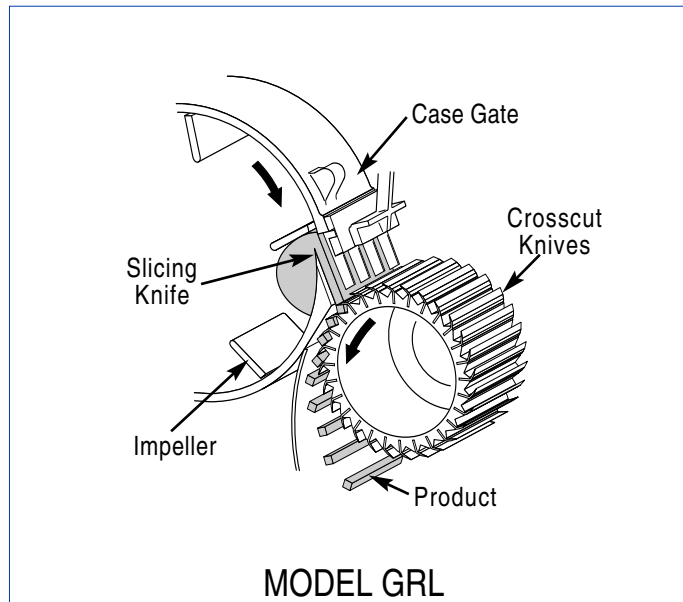

### OPERATING PRINCIPLE

Product is delivered to a feed hopper, then enters the slicing case. Inside the slicing case, a rotating impeller aligns and rotates the potato inside the slicing case using centrifugal force. After the potato travels three-fourths the distance around the slicing case, the first slice is produced. An adjustable gate controls the slice thickness. The potato slice then moves into the crosscut knives where the second cut is produced and discharged from the machine.

### TYPES OF CUTS

A variety of flat or crinkle strip cuts is available.

Slice thickness: Up to 9/16" (14.3 mm)

Crosscut Knife Cuts: 9/32" (7.1 mm), 5/16" (7.9 mm), 3/8" (9.5 mm), 7/16" (11.1 mm), 1/2" (12.7 mm), 9/16" (14.3 mm), .583" (14.8 mm), 5/8" (15.9 mm), 21/32" (16.7 mm), 3/4" (19.1 mm), 7/8" (22.2 mm)



**URSCHEL**  
**LABORATORIES INCORPORATED**  
2503 Calumet Avenue, P.O. Box 2200  
Valparaiso, Indiana 46384-2200 U.S.A.  
219/464-4811 Fax: 219/462-3879  
<http://www.urschel.com>  
E-mail: [info@urschel.com](mailto:info@urschel.com)

**Designers and manufacturers of  
precision size reduction equipment.**

@Urschel is a registered trademark of Urschel Laboratories, Inc.

L2032 JAN 2006 (s.s. 1425)

# Urschel® Model GRL Dimensional Drawing

**Packaging - Processing**  
**Bid on Equipment**  
 1-847-683-7720  
[www.bid-on-equipment.com](http://www.bid-on-equipment.com)

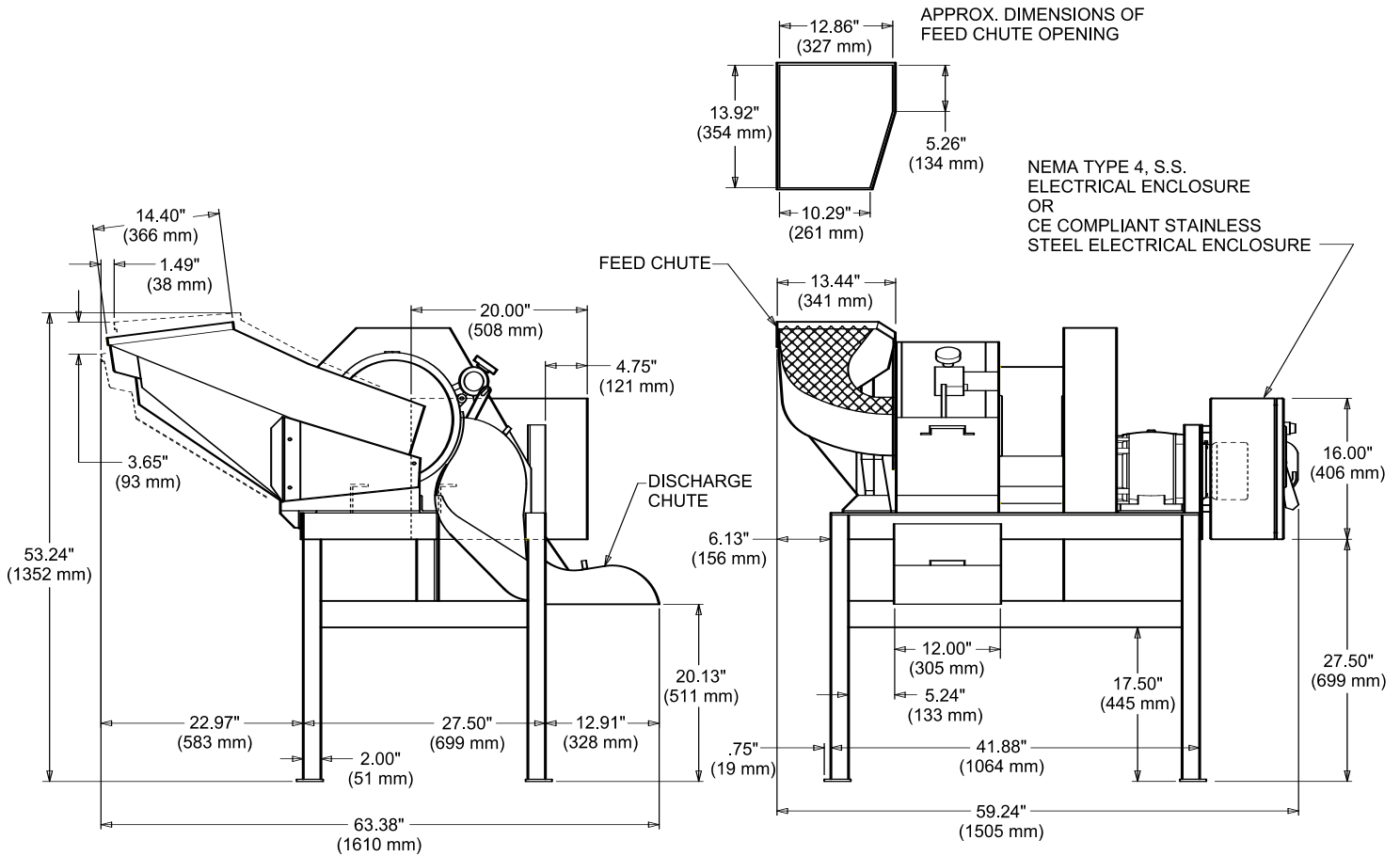

## Your Product Can Be Test Cut

Urschel Laboratories has a complete network of test facilities and experienced service and sales representatives around the world ready to work for you on any size reduction application. Contact your local Urschel Laboratories' representative to schedule a comprehensive, no-obligation test today at [www.urschel.com](http://www.urschel.com)



## URSCHEL LABORATORIES INCORPORATED

2503 Calumet Avenue, P.O. Box 2200  
 Valparaiso, Indiana 46384-2200 U.S.A.  
 219/464-4811 Fax: 219/462-3879  
<http://www.urschel.com>  
 E-mail: [info@urschel.com](mailto:info@urschel.com)

**Designers and manufacturers of  
precision size reduction equipment.**

©Urschel is a registered trademark of Urschel Laboratories, Inc.