

DIVERSACUT **SPRINT**™ DICER

NEW High Performance Small Dicer

Packaging - Processing
Bid on Equipment
 1-847-683-7720
www.bid-on-equipment.com



SPECIFICATIONS

Length: 53.82" (1367 mm)
 Width: 54.33" (1380 mm)
 Height: 65.31" (1659 mm)
 Net Weight: 860 lb (391 kg)
 Motor: 1.5 HP (1.1 kW)

APPLICATIONS

The DiversaCut SPRINT™ Dicer, by Urschel Laboratories, uniformly dices, strip cuts, and slices a wide variety of vegetables, fruits, and meats.

The compact size of the SPRINT combined with the ease of switching over from one cut size or type to another deliver infinite production possibilities.

Maximum product input size is approximately 6.5" (165.1 mm) in any dimension. The machine features continuous operation for uninterrupted production and simplified design for easy cleanup and maintenance.

OPERATING PRINCIPLE

Product is delivered to a feed hopper, then enters a rotating impeller. The resulting centrifugal force holds the product against the inside of the case as the impeller paddles carry the product past the slicing knife. An adjustable case gate on the slicing case allows product to move outward across the edge of the slicing knife. The distance between the edge of the slice gate and the slicing knife edge determines the slice thickness.

As the slices emerge, they are guided between the slicing knife and stripper plate before entering circular knives where they are cut into strips. The strips pass directly into the crosscut knives which make the final cut.

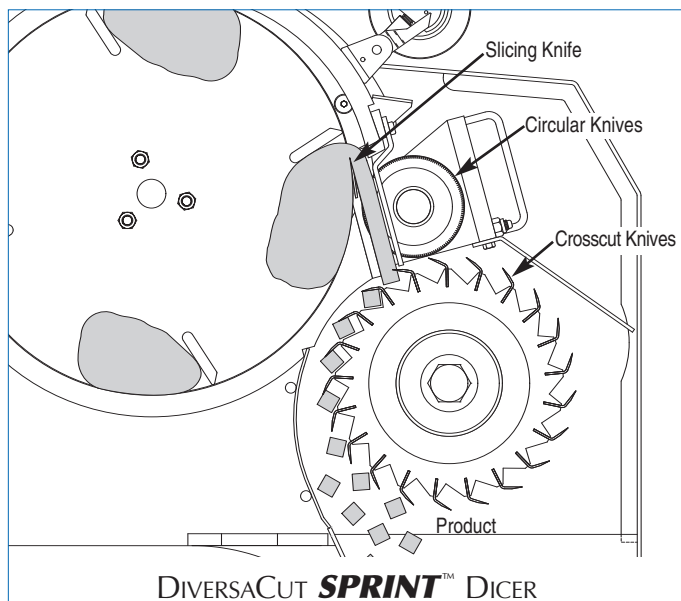

TYPES OF CUTS

Slices: By removing the crosscut spindle and the circular knife spindle, the machine can make slices thru the full range of slice thicknesses.

Flat slices: 1/16 to 1" (1.6 to 25.4 mm)

Crinkle slices: 1/8 to 1" (3.2 to 25.4 mm)

Strip cuts: Flat and crinkle strip cuts in a variety of widths can be made by removing either the crosscut knife spindle or the circular knife spindle assembly.

Minimum flat strips such as .079 x 1/8" x length of product (2 x 3.2 mm x length of product); crinkle strips such as 9/32 x 9/32" x length of product (7.1 x 7.1 mm x length of product); Maximum flat strips such as 1 x 1" x length of product (25.4 x 25.4 mm x length of product); crinkle strips such as 5/8 x 5/8" x length of product (15.9 x 15.9 mm x length of product). Note: Combinations of circular knives or crosscut knives can be used to shorten length of strips.

Dices: A slicing knife, circular knife spindle, and crosscut knife spindle are used for dicing. Changing the dice size is done by using the required cutting spindles and adjusting the slice thickness.

Circular knife cuts: 1/8 to 3" (3.2 to 76.2 mm)

Crosscut knife cuts: 3/32 to 1-1/2" (2.4 to 38.1 mm)

Crosscut knife crinkle cuts: 9/32 to 9/16" (7.1 to 14.3 mm)

If your product application is not mentioned on this page, contact your local Urschel representative to determine the most effective solution to your size reduction needs.

(over)

DIVERSACUT *SPRINT*™ DICER Dimensional Drawing

Packaging - Processing
Bid on Equipment
1-847-683-7720
www.bid-on-equipment.com

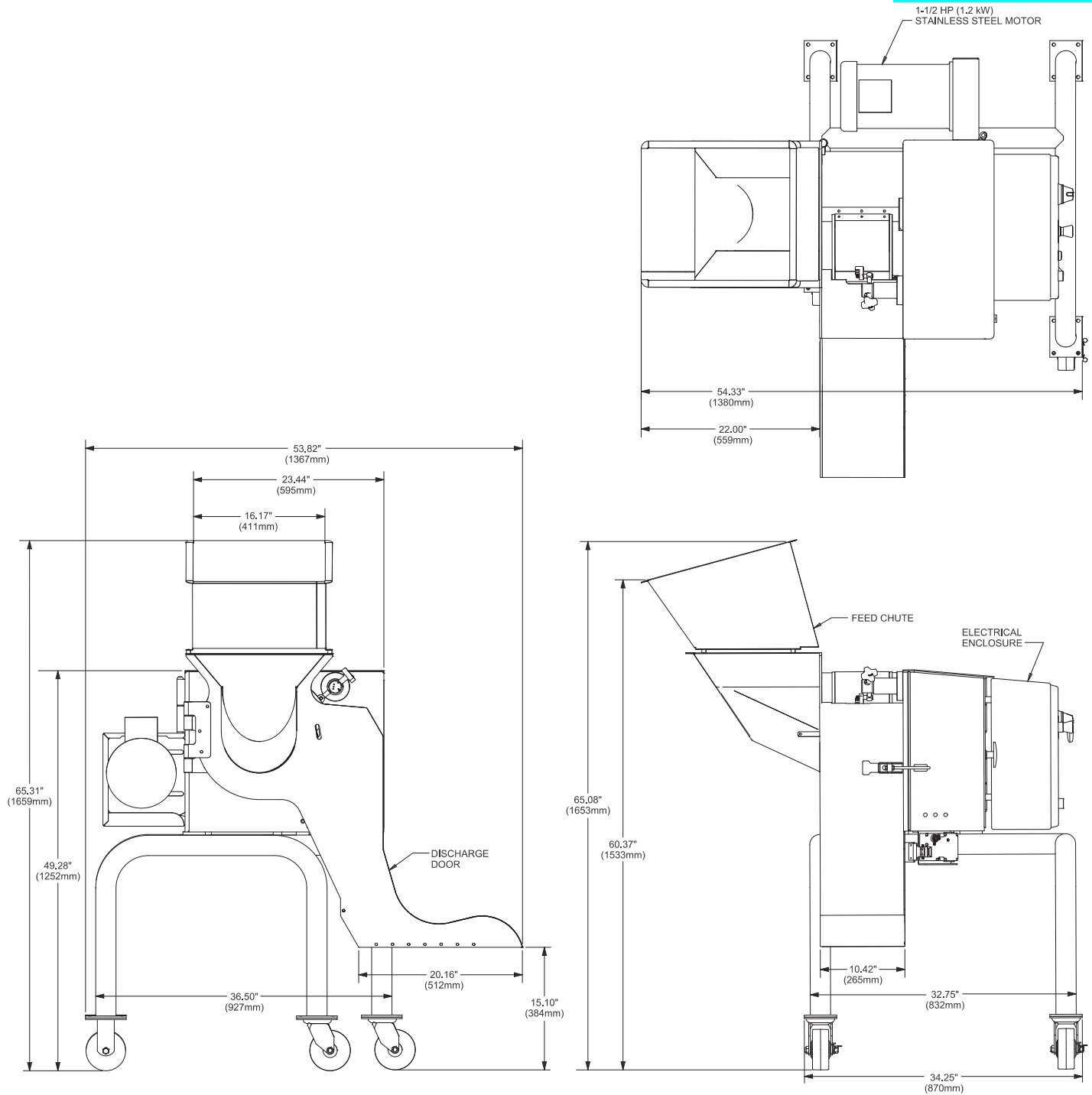

Your Product Can Be Test Cut

Urschel Laboratories has a complete network of test facilities and experienced service and sales representatives around the world ready to work for you on any size reduction application. Contact your local Urschel Laboratories' representative to schedule a comprehensive, no-obligation test today at www.urschel.com

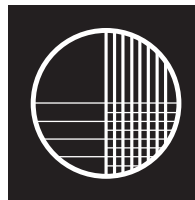

URSCHEL LABORATORIES INCORPORATED

2503 Calumet Avenue, P.O. Box 2200
Valparaiso, Indiana 46384-2200 U.S.A.
219/464-4811 Fax: 219/462-3879
<http://www.urschel.com>
E-mail: info@urschel.com

**Designers and manufacturers of
precision size reduction equipment.**

©DiversaCut and Urschel are registered trademarks of Urschel Laboratories, Inc.
™DiversaCut SPRINT trademark pending.

L2177 APR 2008 (s.s. L2161)