

Comitrol® Processor Model 9300

High Capacity Controlled Particle Size Reduction

Packaging - Processing
Bid on Equipment
 1-847-683-7720
www.bid-on-equipment.com

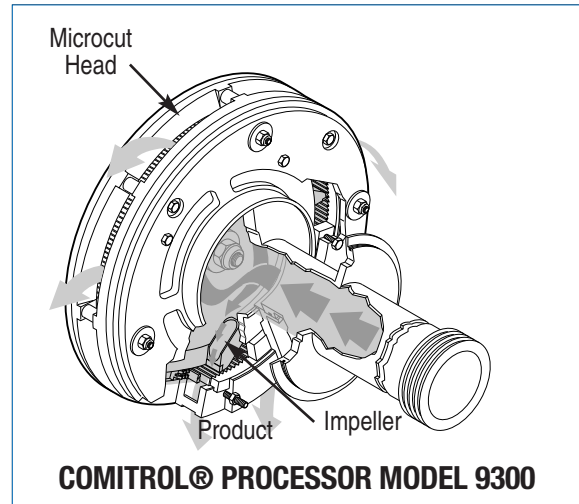

SPECIFICATIONS

Length: 59.74" (1517 mm)
 Width: 60.06" (1526 mm)
 Height: 88.00" (2235 mm)
 Net Weight: 3146 lb (1427 kg)
 Motor: 150 or 200 HP (112 or 149.1 kW)

APPLICATIONS

The †patented Comitrol Processor Model 9300 is recommended for particle size reduction when the final product will be a slurry, paste, or liquid. Equipped with a 12" (304.8 mm) microcut head and impeller, the 9300 is designed for one-pass size reduction of products such as fruits and meats for the production of baby food and peanuts for peanut butter. Depending on your production requirements, the Model 9300 can be pump-fed, or sold equipped with a screw feeder. The machine features continuous operation for uninterrupted production, and simplified design for easy cleanup and maintenance.

OPERATING PRINCIPLE

Product is guided to the center of a high speed, rotating impeller. The resulting centrifugal force moves product outward to the impeller tips, which carry the product past the cutting edges of the stationary microcut head.

The microcut head is a ring of closely spaced blades. Product strikes the exposed cutting edges of the blades with great velocity. This action results in the removal of small particles until reduction is completed. Particles are discharged through the spaces between the blades. Because of high impeller speeds, product remains in the microcut head only a fraction of a second. The product is reduced in precise increments, emerging a uniform size.

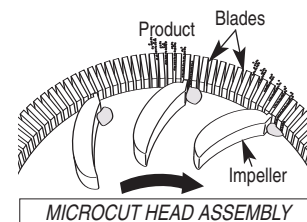

TYPES OF CUTS

Particle sizes ranging from coarse to fine emulsions are possible. To ensure the proper combination of cutting parts, Urschel Laboratories, Inc. recommends your product be tested in one of our worldwide Product Test Cutting Facilities free-of-charge to find the most efficient solution to your size reduction needs.

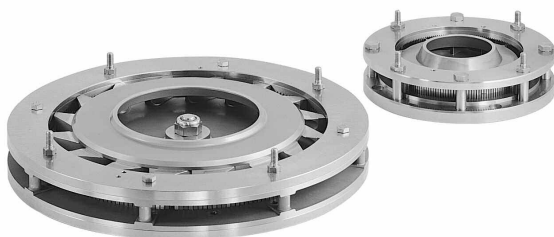

The 12" (304.8 mm) diameter microcut head and impeller compared to the 6" (152.4 mm) microcut head (used on other Comitrol Processors)

†The COMITROL Processor Model 9300 may contain parts protected by U.S. Patent 5201469.

If your product application is not mentioned on this page, contact your local Urschel representative to determine the most effective solution to your size reduction needs.

Comitrol® Processor Model 9300 Dimensional Drawing

Packaging - Processing
Bid on Equipment
 1-847-683-7720
www.bid-on-equipment.com

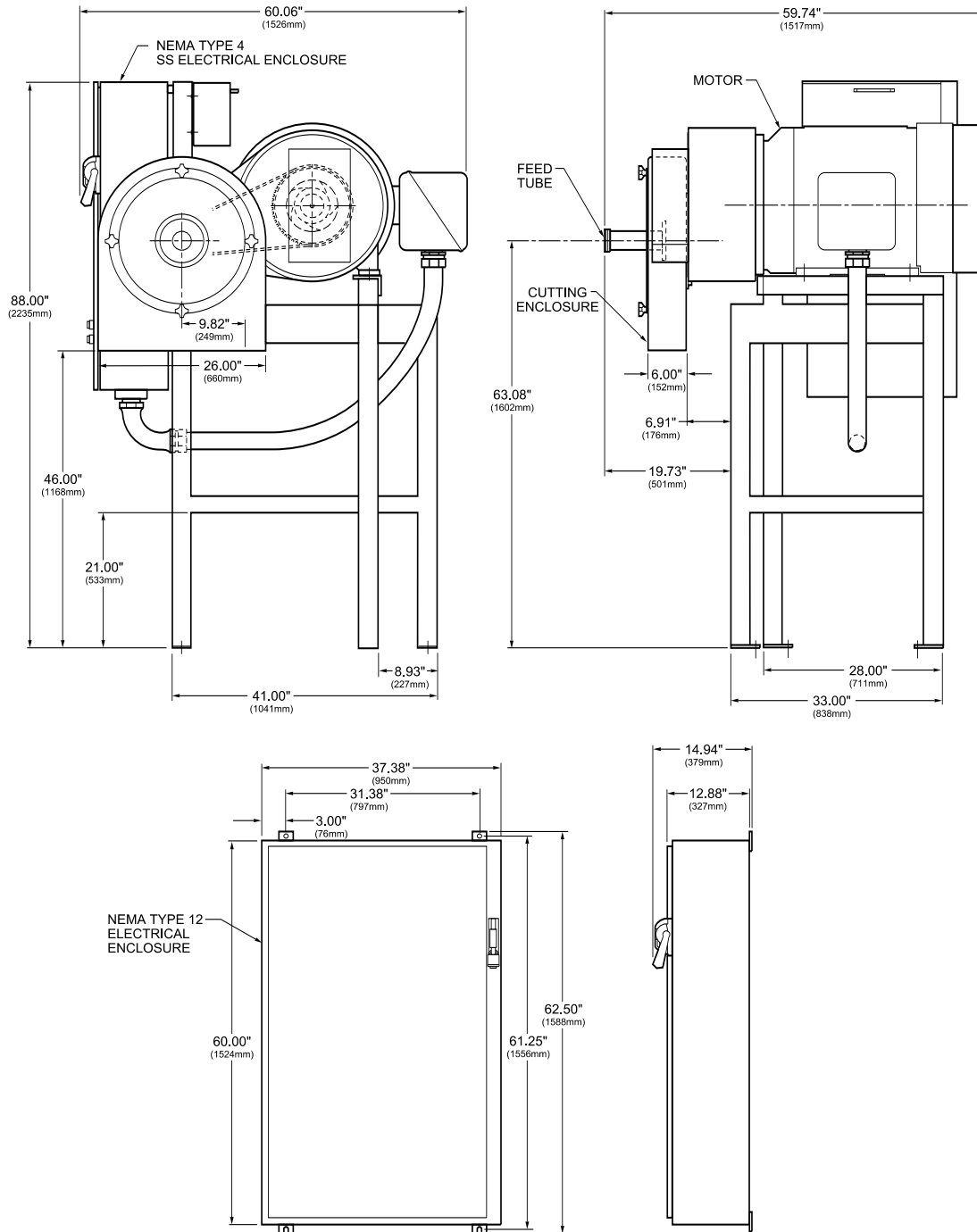

Your Product Can Be Test Cut

Urschel Laboratories has a complete network of test facilities and experienced service and sales representatives around the world ready to work for you on any size reduction application. Contact your local Urschel Laboratories' representative to schedule a comprehensive, no-obligation test today at www.urschel.com



URSCHEL

LABORATORIES INCORPORATED

2503 Calumet Avenue, P.O. Box 2200
 Valparaiso, Indiana 46384-2200 U.S.A.
 219/464-4811 Fax: 219/462-3879

<http://www.urschel.com>
 E-mail: info@urschel.com

**Designers and manufacturers of
 precision size reduction equipment.**

©Comitrol and Urschel are registered trademarks of Urschel Laboratories, Inc.