

Label Applicators

Where labeling begins.

SL1500

- Stepper driven
- Digitally controlled
- Multi-level menu system
- Photoelectric label sensing



Wipe-on

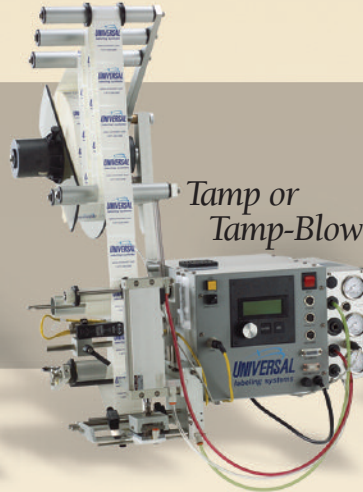

Tamp or
Tamp-Blow

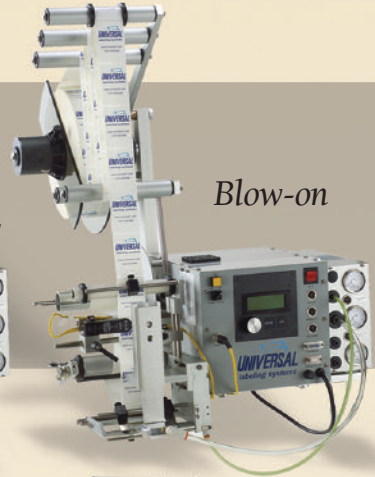

Blow-on



SL2000

- Stepper driven
- High-speed applicator
- Digitally controlled
- Photoelectric label sensing

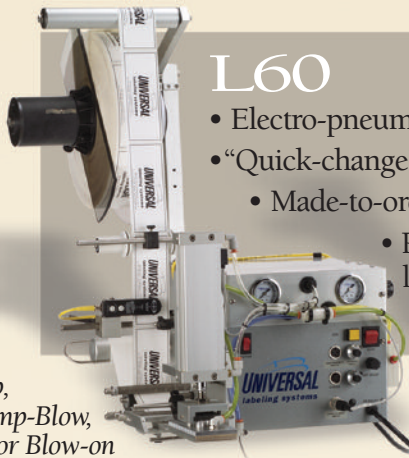

L60

- Electro-pneumatic
- “Quick-change” tamp heads
- Made-to-order
- Photoelectric label sensing

Tamp,
Tamp-Blow,
or Blow-on

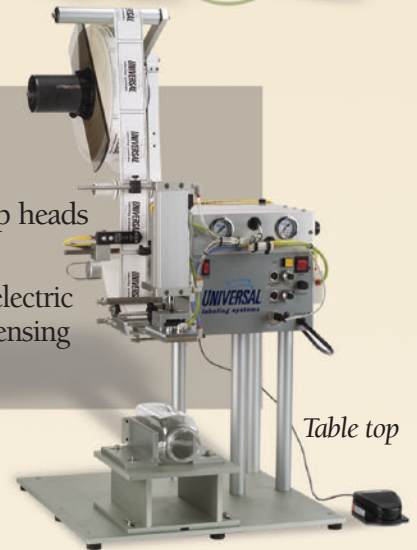
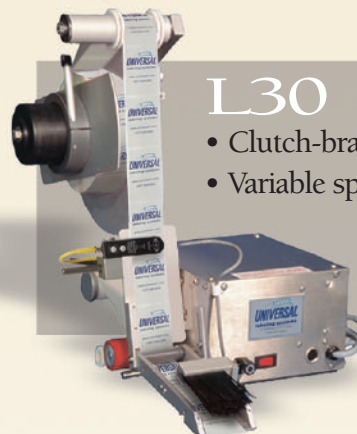

Table top



L15

- Clutch-brake driven
- Variable speed
- Start and stop delay
- Photoelectric label sensing



L30

- Clutch-brake driven
- Variable speed
- Photoelectric label sensing

Packaging - Processing
Bid on Equipment
1-847-683-7720
www.bid-on-equipment.com

Engineering
labeling solutions.

SPECIFICATIONS

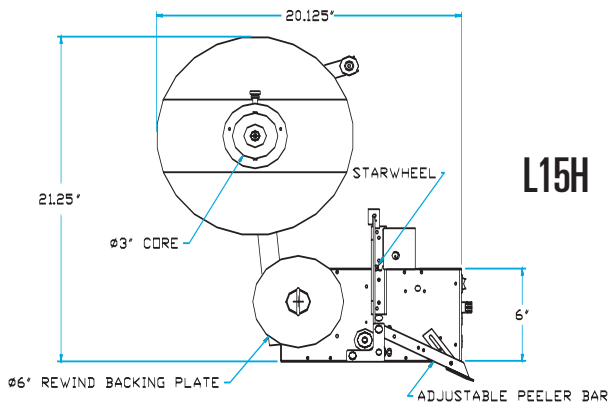

L15H

L15H

- Dimensions: 19.5"W x 21"D x 22.5" H
- Label dispense speed: up to 1200" per min.
- Web width: up to 6.5" (standard)
- Label roll capacity: up to 12" OD
- Electric: 120 VAC =+/-10%

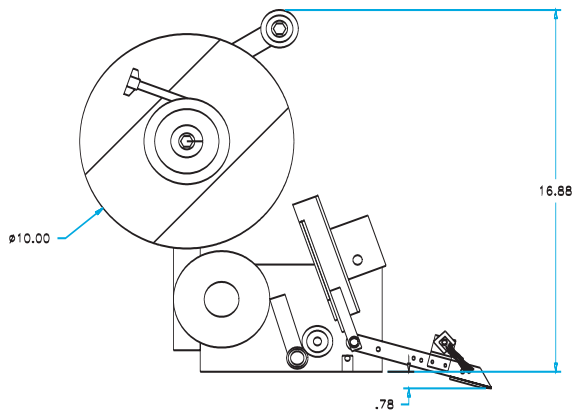

L30

L30

- Dimensions: 14.25"W x 20.5"D x 18" H
- Label dispense speed: up to 700" per min.
- Web width: up to 2.125"
- Label roll capacity: up to 10" OD
- Electric: 120 VAC =+/-10%

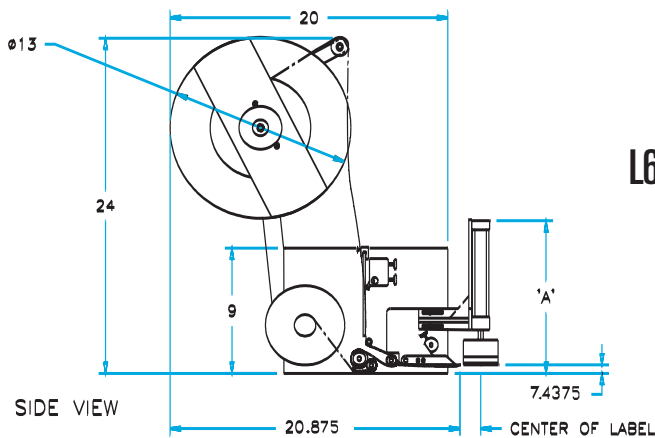

L60

L60

- Dimensions: 19"W x 23"D x 24.75" H
- Label dispense speed: 529" per min. (fixed)
- Web width: up to 6.5" (standard; 8.125 optional)
- Label roll capacity: up to 12" OD
- Electric: 120 VAC =+/-10%
- 40 PSI tamp/80 PSI blow-on

SL1500

- Dimensions: 19.625"W x 20"D x 30.5" H
- Label dispense speed: up to 1500" per min.
- Web width: up to 6.375" (standard; 8.125 optional)
- Label roll capacity: up to 12" OD
- Electric: 120 VAC =+/-10%
- Air for tamp version: 40 PSI/80 PSI blow-on

SL2000

- Dimensions: 19.5"W x 22"D x 33.75" H
- Label dispense speed: up to 3000" per min.
- Web width: up to 6.375" (standard; 8.125 optional)
- Label roll capacity: up to 16" OD
- Electric: 120 VAC =+/-10%
- Air for tamp version: 40 PSI/80 PSI blow-on

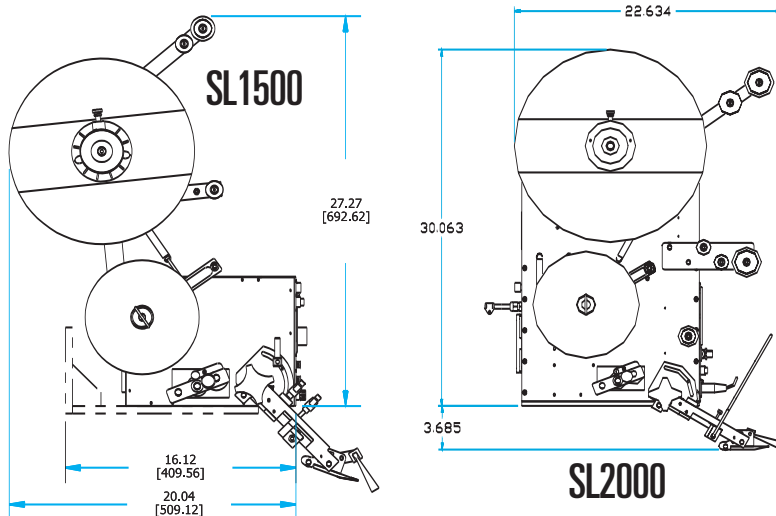

SL1500

SL2000

Universal Labeling Systems, Inc.

3501 8th Avenue South • St. Petersburg, FL 33711
 1-877-236-0266 • sales@universal1.com
 www.universal1.com

Packaging - Processing
Bid on Equipment
 1-847-683-7720
 www.bid-on-equipment.com