

Project	Quantity	Item #
Model Specified:		CSI Section 11400

"N-Width" Reach-In Refrigerator-Freezer Models/Self-Contained



Model RDT232NUT-FHS
(shown with standard left/right hinging)



Stainless Exterior
& Interior

Two & Three Section Models, 32" Deep

2-Section Full Length Door Model	RDT232NUT-FHS
3-Section Full Length Door Model	RDT332NUT-FHS
2-Section Half Length Door Model	RDT232NUT-HHS
3-Section Half Length Door Model	RDT332NUT-HHS



Stainless Exterior,
Anodized Aluminum Interior

2-Section Full Length Door Model	ADT232NUT-FHS
3-Section Full Length Door Model	ADT332NUT-FHS
2-Section Half Length Door Model	ADT232NUT-HHS
3-Section Half Length Door Model	ADT332NUT-HHS

The R & A Series represent Traulsen's Top-of-the-Line product offering. The "N-Width" reach-in refrigerator/freezer models are all designed to offer maximum interior storage capacity. Each is supplied standard with such high quality features as balanced refrigeration systems, microprocessor controls, communications ability and stainless steel exteriors. Additionally, they offer the widest range of optional accessories to choose from, and can be specified for use with many different applications, including: Foodservice, Correctional, Institutional, Export, etc.

Standard Product Features

- R-Series: Stainless Steel Exterior & Interior
- A-Series: Stainless Steel Exterior/Anodized Aluminum Interior
- INTELA-TRAUL® Microprocessor Control System
- Balanced, Self-Contained Dual Refrigeration Systems Using R-134a & R-404A Refrigerants
- Scroll Blower Type Evaporator Fan
- Biased Return Air Duct
- Full or Half Length Stainless Steel Doors With Locks
- Self-Closing Doors With Stay Open Feature At 120 Degrees
- Guaranteed For Life Cam-Lift Hinges
- Guaranteed For Life Horizontal Work Flow Door Handle
- Standard Door Hinging: 232N = Left/Right, 332N = Left/Right/Right (other hinging available)
- Automatically Activated Incandescent Lights
- Stainless Steel Breaker Caps
- Adjustable Wire Shelves (installed at the factory)
- Automatic Non-Electric Condensate Evaporator
- Magnetic Snap-In Door Gaskets
- Gasket Protecting Metal Door Liner
- Controllable Anti-Condensate Door Perimeter Heaters
- Thermostatic Expansion Valve Metering Device
- Stainless Steel One-Piece Louver Assembly
- 9' Cord & Plug Attached (2 section models only)
- Set of Four (4) 6" High Adjustable Stainless Steel Legs
- One Year Parts And Labor Warranty
- Two Year Control Warranty (parts and labor)
- Five Year Compressor Warranty

Options & Accessories

- Stainless Steel Finished Back With Rear Louvers
- Re-Hinging Feature For Door(s)
- No. 1 Type Tray Slides To Accommodate either (1) 18" x 26" or (2) 14" x 18" Sheet Pans, Adjustable To 2" O.C.
- No. 2 Type Tray Slides To Accommodate (1) 18" x 26" Sheet Pans, Adjustable To 2" O.C.
- No. 3 Type Tray Slides To Accommodate (2) 12" x 20" Steam Table Pans, Adjustable To 2" O.C.
- No. 4 Type Tray Slides To Accommodate (1) 18" x 26" Sheet Pans (chrome rod type, equips 1/2 section)
- Universal Type Tray Slides To Accommodate Either (1) 18" x 26" or (2) 14" x 18" Sheet Pans, or (2) 12" x 20" Steam Table Pans, Adjustable To 4" O.C.
- Additional Wire Shelves
- Locking Hasps (padlocks supplied by others)
- Export 220/50/1 Voltage
- 208/115/60/1 Voltage In Lieu Of Standard 115/60/1
- Stainless Steel Shelves
- Kool Klad Exterior Laminate Decor
- Set of Four (4) 6" Or 4-5/8" High Casters In Lieu of Legs
- 4-1/2" High Stainless Steel Base In Lieu of Legs
- 6" High Stainless Steel Kickplate (for use with standard legs)
- Prison/Correctional Facilities Options
- Remote Applications (see spec sheet TR35837 for details)
- Clear Glass Door(s) In Place Of One Or More Refrigerator Section Door(s)
- Water Cooled Self-Contained Condenser Suitable For Connection To Glycol
- Two Year Service/Labor Warranty Available



Listed by Underwriters Laboratories Inc., to U.S. and Canadian safety standards and Listed by NSF International.

Approval: _____



TRAULSEN
4401 BLUE MOUND RD.
PHONE 1 (800) 825-8220
Website: www.traulsen.com

FT. WORTH, TX 76106
FAX-MKTG. 1 (817) 624-4302

Packaging - Processing
Bid on Equipment
1-847-683-7720
www.bid-on-equipment.com

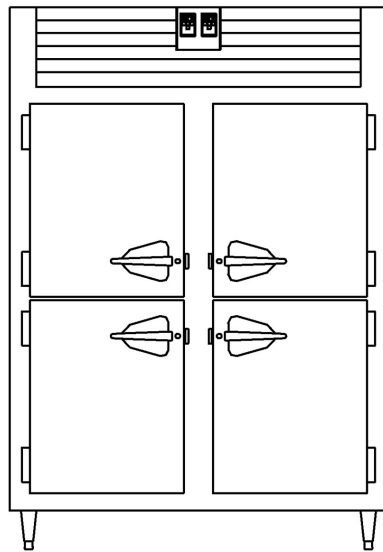

Elevation - R/ADT232NUT

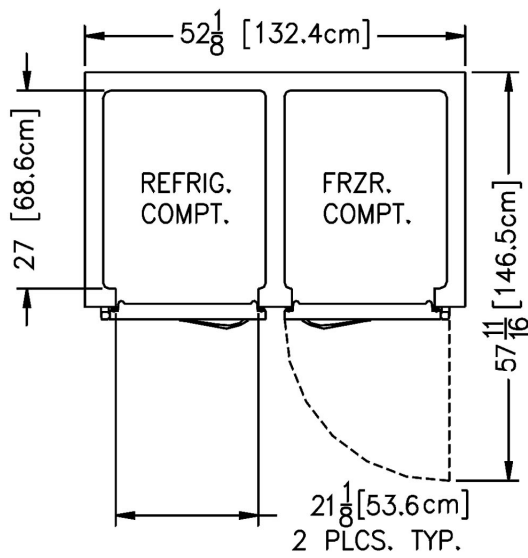

Plan - R/ADT232NUT

TRAULSEN
 4401 BLUE MOUND RD.
 PHONE 1 (800) 825-8220
 Website: www.traulsen.com

FT. WORTH, TX 76106
 FAX-MKTG. 1 (817) 624-4302



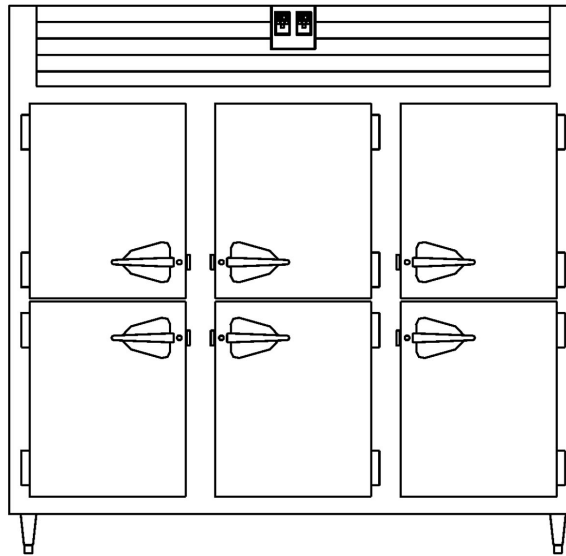

Elevation - R/ADT332NUT

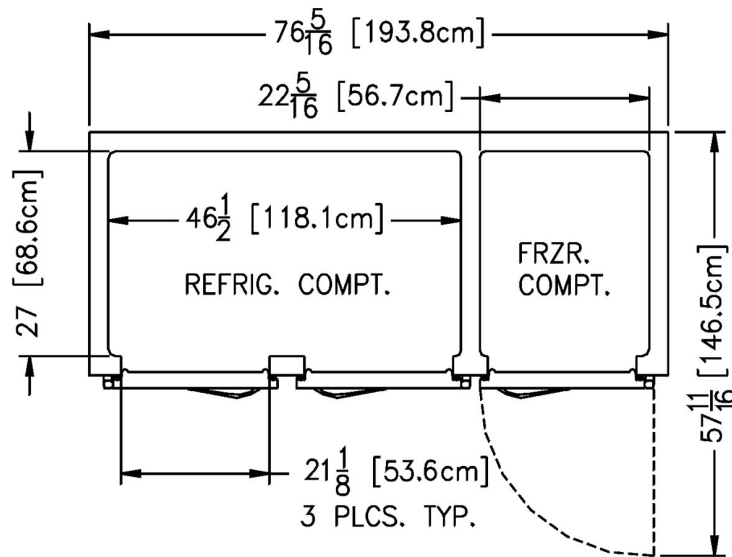

Plan - R/ADT332NUT

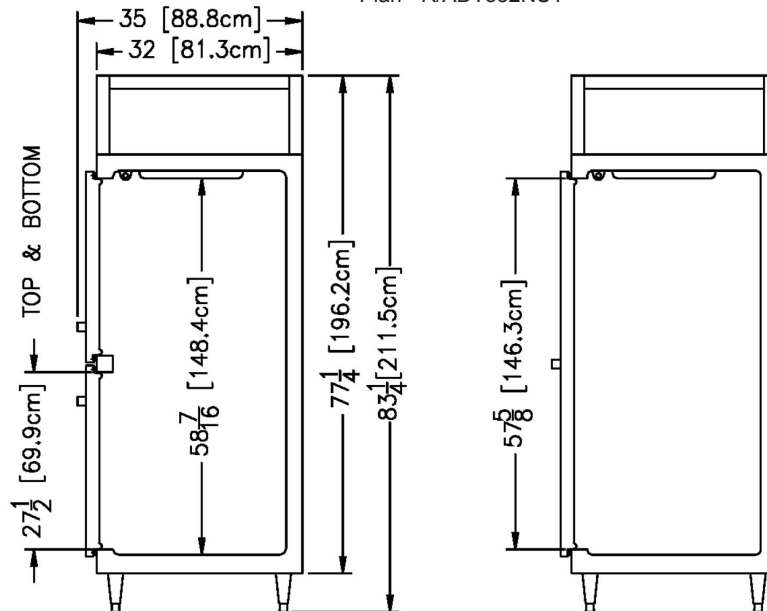

Section -
All Models



TRAUlsen
4401 BLUE MOUND RD.
PHONE 1 (800) 825-8220
Website: www.traulsen.com

FT. WORTH, TX 76106
FAX-MKTG. 1 (817) 624-4302

Packaging - Processing
Bid on Equipment
1-847-683-7720
www.bid-on-equipment.com

Project	Quantity	Item #
Model Specified:		CSI Section 11400

Specifications

Construction, Hardware and Insulation

Cabinet exterior front, one piece sides, louver assembly and doors are constructed of 20 gauge stainless steel with #4 finish. Cabinet interior and door liners are constructed of stainless steel (anodized aluminum in the A-Series). The exterior cabinet top, back and bottom are constructed of heavy gauge aluminized steel. A set of four (4) adjustable 6" high stainless steel legs are included.

Doors are equipped with a gasket protecting metal door pan, removable plug cylinder locks and guaranteed for life cam-lift, gravity action, self-closing metal, glide hinges with stay open feature at 120 degrees. Hinges include a concealed switch to automatically activate the interior incandescent lighting. Guaranteed for life, work flow door handles are mounted horizontally over recess in door which limits protrusion from door face into aisles. Doors have seamless, polished metal corners.

Easily removable for cleaning, vinyl magnetic door gasket assures tight door seal. Anti condensate heaters are located behind each door opening.

Both the cabinet and door(s) are insulated with an average of 2" thick high density, non-CFC, foamed in place polyurethane.

DIMENSIONAL DATA	R/ADT232NUT	R/ADT332NUT
Net capacity total cu. ft.	38.5 (1091 cu l)	60.7 (1720 cu l)
Net capacity refriger. cu. ft.	19.7 (558 cu l)	41.9 (1187 cu l)
Net capacity freezer cu. ft.	18.8 (533 cu l)	18.8 (533 cu l)
Length - overall in.	52 $\frac{1}{8}$ (132.4 cm)	76 $\frac{1}{16}$ (193.8 cm)
Depth - overall in.	35 (88.8 cm)	35 (88.8 cm)
Depth - over body in.	32 (81.3 cm)	32 (81.3 cm)
Depth - door open 90° in.	57 $\frac{1}{16}$ (146.5 cm)	57 $\frac{1}{16}$ (146.5 cm)
Clear door width in.	21 $\frac{1}{8}$ (53.6 cm)	21 $\frac{1}{8}$ (53.6 cm)
Clear half-door height in.	27 $\frac{1}{2}$ (69.9 cm)	27 $\frac{1}{2}$ (69.9 cm)
Clear full-door height in.	57 $\frac{1}{8}$ (146.3 cm)	57 $\frac{1}{8}$ (146.3 cm)
Height - overall on 6" legs	83 $\frac{1}{4}$ (211.5 cm)	83 $\frac{1}{4}$ (211.5 cm)
No. Standard Shelves	6	9
Shelf area total sq. ft. ¹	29.2 (2.71 sq m)	51.9 (4.82 sq m)
Shelf area refriger. sq. ft. ¹	14.6 (1.36 sq m)	34.6 (3.21 sq m)
Shelf area freezer sq. ft. ¹	14.6 (1.36 sq m)	17.3 (1.61 sq m)
RDT Net Wt. lbs.	665 (302 kg)	860 (390 kg)
ADT Net Wt. lbs.	585 (265 kg)	750 (340 kg)
ELECTRICAL DATA		
Voltage	115/60/1	115/60/1
Feed wires with Ground	3	3
Full load amperes	16.0	21.6
REFRIGERATION DATA		
Refrigerant - Refrigerator	R-134a	R-134a
Refrigerant - Freezer	R-404A	R-404A
BTU/HR H.P. - Refrigerator ²	1730 ($\frac{1}{4}$ HP)	4200 ($\frac{1}{2}$ HP)
BTU/HR H.P. - Freezer ²	2170 ($\frac{1}{2}$ HP)	2160 ($\frac{1}{2}$ HP)

NOTES

NOTE: Figures in parentheses reflect metric equivalents.

- 1= Area of standard shelf complement only, does not include storage area of additional shelves or available on cabinet bottom.
- 2= Based on a 90 degree F ambient and 20 degree F evaporator for the refrigerated section and a 90 degree F ambient and -20 degree F evaporator for the freezer section.
- 3= For approximate remote weights deduct 40 lbs. from respective net or gross weight. For other information on remote models, please refer to spec sheet TR35837.

Refrigeration System

A top mounted, self-contained, balanced refrigeration system using R-134a and R-404A refrigerants is conveniently located behind the one piece louver assembly. These models feature an easy to clean front facing condenser, thermostatic expansion valve, air-cooled hermetic compressor, plenum effect blower coil, large, high humidity evaporator coil located outside the food zone and a top mounted non-electric condensate evaporator.

Biased return air duct protects against introduction of warm kitchen air, promoting even temperature maintenance and efficient operation.

A 9' cord and plug is provided standard on two section models. Standard operating temperatures are 34 to 38°F for the refrigerator compartment and 0 to -5°F for the freezer compartment.

Controller

The easy to use water resistant INTELA-TRAUL® microprocessor control system is supplied standard. Unit is NAFEM Data Protocol communication (NDP) ready. Optional hardware required to be NDP compliant. Third party software required for network connection. It includes a 3-Digit LED Display, Fahrenheit or Celsius Temperature Scale Display Capability, and an RS485 data port. In addition it includes audio/visual alarms for: Hi/Lo Cabinet Temperature, Door Open, Clean Condenser, Evaporator Coil and Discharge Line Sensor Failures, and Power Supply Interruption. A separate control is provided for both the refrigerator and freezer compartments.

Interior

Standard interior arrangements include three (3) wire shelves per section, mounted on shelf pins. Shelves are full-width, and do not have any large gaps between them requiring the use of "bridge" or "junior shelves." Recommended load limit per shelf should not exceed 225 lbs. Optional tray slides may be purchased in combination with, or in lieu of these. Both standard and optional interior arrangements are completely installed at the factory.

Warranties

Both a one year parts and labor warranty and a five year compressor warranty (self-contained models only) are provided standard. An optional 2nd year extended parts and labor warranty is also available. In addition the INTELA-TRAUL® controls are warranted by a two year parts and labor warranty.



**Equipped With One NEMA 5-20 P Plug
(2 section models only)**

NOTE: Full load amps and plug style may vary depending on electrical options chosen and condensing unit employed.

REQUIRED CLEARANCES

In order to assure optimum performance, the condensing unit **MUST** have an adequate supply of air for cooling purposes. Therefore, the operating location must either have a minimum of 12" clearance overhead of the condensing unit or allow for unrestricted air flow at the back of the unit. Clearance of at least 12" above is required in order to perform certain maintenance tasks.

NOTE: When ordering please specify: Voltage, Hinging, Door Size, Options and any additional warranties.

Continued product development may necessitate specification changes without notice.
Part No. TR35780 (revised 4/10)

TRAULSEN
4401 BLUE MOUND RD.
PHONE 1 (800) 825-8220
Website: www.traulsen.com

FT. WORTH, TX 76106
FAX-MKTG. 1 (817) 624-4302

Traulsen