

Project

Quantity

Item #

Model Specified:

CSI Section 11400

Mobile Seafood Display Cabinet/ Self-Contained



Model TD078FT

Traulsen's "Seafood Display" cabinet is designed to provide safe, mobile refrigerated storage for various raw and/or frozen cooked products, such as shrimp, salmon, tuna, steaks, etc.

The proprietary refrigeration system provides cold air flow over the product to retard the rate of ice melt while maintaining safe food temps throughout the day without drying or freezing the product.

The cabinet interior is designed to hold ten 18" x 26" sheet pans, providing ample refrigerated storage to allow for more frequent replenishment of product in the display well. Additional products can also be conveniently staged on pans in the cold room and then placed directly onto the pan slides when needed, providing for improved degree of food safety by limiting the number of surfaces and individuals which come into contact with the food product.

The Seafood Display cabinet is also designed to allow for easy cleaning. Once the product, ice, pans, air baffles, and fan blades have been removed, the entire product well can be hosed out with sanitizer to eliminate odors. Note that the cabinet area behind the doors should not be cleaned with a hose under any circumstances.

Built for years of reliable use, the Seafood Display cabinet epitomizes the high quality and performance Traulsen is so well known for, and represents a new standard in refrigerated displays which do not compromise between performance or product visibility/merchandising concerns.



Model TD078FT

Standard Product Features

- Exclusive Refrigeration System Designed For All Day Use And Easy Cleaning of the Product Display Area
- INTELA-TRAUL[®] Microprocessor Control System
- High Quality Stainless Steel Exterior Construction
- Durable Coved Stainless Steel Interior
- Two (2) Self-Closing Stainless Steel Doors Hinged Left/Right
- Magnetic Snap-In Door Gaskets For Tight Door Seal
- Ten (10) Tray Slides for 18" x 26" Sheet Pans (5 per door)
- CFC Free R-404A Refrigerant
- 5" High Heavy Duty Casters (two fixed for mobility)
- NEMA 5-20P Cord & Plug Attached
- Automatic Condensate Removal
- Convenient Valve For Occasional Draining of Ice Melt Off and to Facilitate Cleaning
- One Year Service Labor Warranty
- Two Year Control Parts/Labor Warranty
- Five Year Compressor Warranty

Special Seafood Display Features

- Transport Latch (keeps door closed during movement)
- Front POS Shelf (for signage or merchandising)
- Two Bumper Levels on Front & Sides to Prevent Impact Damage From Shopping Carts
- Holder for the Plastic Bags Used with King Crab Legs
- Removable, Four (4) Piece Clear Canopy For Easy Product Viewing
- Full Set of Special "Display Pans" & Three Plastic Product Dividers



Listed by Underwriters Laboratories Inc. and the NSF International in accordance with ANSI/NSF7.

Approval: _____



TRAULSEN
4401 BLUE MOUND RD.
PHONE 1 (800) 825-8220
Website: www.traulsen.com

FT. WORTH, TX 76106
FAX-MKTG. 1 (817) 624-4302

Packaging - Processing
Bid on Equipment
1-847-683-7720
www.bid-on-equipment.com

Project	Quantity	Item #
Model Specified:		CSI Section 11400

Specifications

CONSTRUCTION, HARDWARE AND INSULATION

Unit exterior top, front, display well and sides are constructed of stainless steel. Cabinet interior is constructed of stainless steel and insulated with 2" insulation throughout.

The refrigerated pan well is designed to accommodate special pans which allow for water run-off (provided by Traulsen). This is covered by a clear 4-piece canopy designed for maximum product visibility and easy removal for cleaning.

Doors are equipped with self-closing hinges and a horizontal metal handle which does not protrude beyond the operator side. Each includes an easily removable for cleaning vinyl magnetic door gasket which assures a tight door seal. A transport latch is also included.

INTERIOR ARRANGEMENTS & SUPPORTS

Unit includes five (5) Tray slides for 18" x 26" pans per door, completely installed at the factory. Cabinet is mounted on a set of 5" high casters.

CONTROLLER

The easy to use water resistant INTELA-TRAUL® microprocessor control system is supplied standard. It includes a 3-Digit LED Display, Fahrenheit or Celsius Temperature Scale Display Capability, and an RS485 data port. In addition it includes audio/visual alarms for: Hi/Lo Cabinet Temperature, Clean Condenser, Evaporator Coil and Discharge Line Sensor Failures.

DIMENSIONAL DATA	TD078FT
Length - Overall in.	77-1/4 ¹
Depth - Overall in.	37.970 ²
Clear Door Width in.	23-5/8
Clear Door Height in.	15-5/8
Door Hinging	Left/Right
Interior Pan Capacity (18" x 26")	10
Operator Surface Height in.	42
Height - Overall in.	59-1/8
ELECTRICAL DATA	
Voltage	115/60/1
Full Load Amperes	16.0
NEMA Plug	5-20P
REFRIGERATION DATA	
Refrigerant	R-404A
BTU/HR ¹	7560
Compressor HP	3/4 HP

NOTES

1= Cabinet only, add 2" to allow for bumper.

2= Less scale and mounting bracket.

Based on a 86 degree F ambient and 20 degree F evaporator.



REFRIGERATION SYSTEM

The self-contained refrigeration system cools the cabinet interior, as well as the raised pan well, through use of an exclusive coil/fan arrangement which also allows for easy cleaning. Ice is necessary only for appearance, and is not required for temperature maintenance. A convenient drain valve is provided to allow for any resulting ice melt-off to be drained away as needed. A cord and plug is supplied standard. Standard interior cabinet operating temperature is 34 to 38°F.

WARRANTIES

Both a one year parts and labor warranty and a five year compressor warranty are provided standard. An optional 2nd year extended parts and labor warranty is also available.

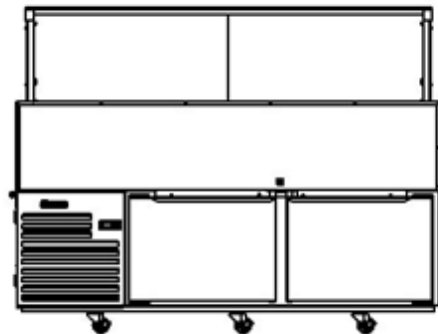

Elevation View

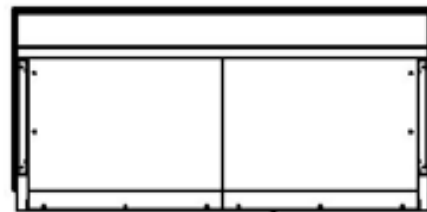

Plan View

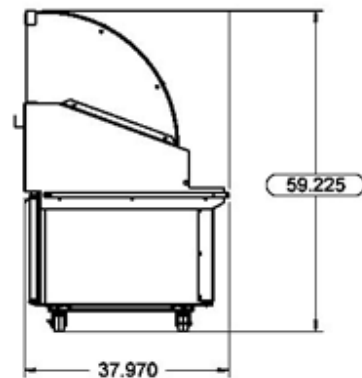

Section View

Continued product development may necessitate specification changes without notice.

Part No. TR99999 (revised 3/10)

TRAULSEN
4401 BLUE MOUND RD.
PHONE 1 (800) 825-8220
Website: www.traulsen.com

FT. WORTH, TX 76106
FAX-MKTG. 1 (817) 624-4302