

Project

Quantity

Item #

Model Specified:

CSI Section 11400

100 lb. Capacity Reach-in Blast Chiller Model/Self-Contained



Model RBC100



Model RBC100
(shown with optional casters)

Like all blast chillers, Traulsen's model RBC100 is designed to quickly cool its respective capacity of hot product through the HACCP danger zone as fast, or faster, than any other equivalent brand on the market (approximately 90-minutes). However, in addition to the outstanding cabinet construction synonymous with Traulsen, what differentiates these models from competition is the operational flexibility and labor savings inherent in their easy-to-use controls, automatic HACCP documentation, and a variety of operator friendly features, such as our exclusive "By-Product" chill mode.

High Quality Standard Features

- Stainless Steel Exterior & Interior Construction
- Communications Capable & NAFEM Data Protocol Compliant
- On-Board Batch Data Printer
- Three (3) Chilling Functions
 - 1) Blast Chill (135° to below 41°F in approx. 90-minutes)
 - 2) Soft Chill (for use with delicate products such as fresh seafood and produce)
 - 3) Freeze (to 0°F)
- Three (3) Chilling Modes For Each Chilling Functions
 - 1) By Temperature
 - 2) By Product
 - 3) By Time
- Automatic Refrigerated Hold Mode After Each Cycle
- Two-Stage Self-Contained Refrigeration System (promotes energy efficient operation and maximizes compressor life)
- Magnetic Door Gasket
- Self-Closing and Stay Open Door Features
- Rehingable Stainless Steel Door (Standard Hinged Left) With Cylinder Lock
- Five (5) Pairs of Tray Slides To Accommodate Either Ten (10) 12" x 20" Steam Table or Five 18" x 26" Sheet Pans
- Horizontal Work Flow Door Handles - Guaranteed for Life
- Set Of Four (4) 6" High Adjustable Stainless Steel Legs
- Automatic Defrost With On-Demand Feature
- Adjustable Product Chill Target Temperatures
- Adjustable Product Holding Temperature
- One Year Parts/Labor Warranty
- Five Year Compressor Warranty

Exclusive Features

- Patented, Easy-to-Use SmartChill® Control System
- One Button EZ-START™ Feature
- Three (3) SmartProbes™ Automatically Register Product Temperatures
- On-Board Label Printer (prints adhesive labels which can be placed directly on to product containers)
- By Product Chill Mode (allows the operator to pre-program into memory the individual chilling requirements of a variety of different food products)

Options & Accessories

- Correctional Facility Package for Blast Chill
- BCACC-60387: SmartChill® PC Communications Software Package
- BCACC-NDPG1: Communications Gateway (required for use within a NAFEM Data Protocol compliant network)
- BCACC-BMCE: 208V Bottom Mounted Electric Condensate Evaporator
- Set Of Four (4) 6" High Locking Casters
- One or Two Day On-Site Blast Chill Training
- Optional Right Hand Hinging
- Water Cooled Self-Contained Condenser Suitable For Connection To Glycol
- Modification For Use With Hobart CE6 & CE10 Combi Oven Racks (for use with other brands please contact factory)
- Two Year Service/Labor Warranty Available



Listed by Underwriters Laboratories Inc. and CSA certified by Underwriters Laboratories Inc. and classified by Underwriters Laboratories in accordance with ANSI/NSF7.

Approval: _____



TRAULSEN
4401 BLUE MOUND RD.
PHONE 1 (800) 825-8220
Website: www.traulsen.com

FT. WORTH, TX 76106
FAX-MKTG. 1 (817) 624-4302

Packaging - Processing
Bid on Equipment
1-847-683-7720
www.bid-on-equipment.com

| | | |
|------------------|----------|-------------------|
| Project | Quantity | Item # |
| Model Specified: | | CSI Section 11400 |

Specifications

Hardware, Insulation and Construction

Exterior sides, front, door, top, rear and interior are constructed of stainless steel. Exterior bottom is constructed of heavy gauge aluminized steel. Door is equipped with a cylinder lock and guaranteed for life cam-lift, self-closing hinges with stay open feature at 120°. Guaranteed for life work-flow, door handle is mounted horizontally over recess in door which limits protrusion from door face into aisle ways. Easily removable for cleaning, vinyl magnetic gasket assures tight door seal. Anti-condensate heater is located behind door opening. Door is hinged left as standard. Both cabinet and door are insulated with high density, non-CFC foamed in place polyurethane.

Refrigeration System

Dual refrigeration systems are utilized in order to prevent short cycling, providing for energy efficient operation and maximizing compressor life. These combine their efforts through a unique air circulation system within the food zone. During Blast Chill cycles both systems are in full operation. At the completion of any chill or freeze cycle, one refrigeration system remains in use to maintain proper refrigerated storage temperatures. Each unit requires provision of a floor drain or optional condensate evaporator for condensate removal.

Interior

Five pairs of tray slides to accommodate two each 12" x 20" x 2 1/2" pans for a total capacity of ten pans is provided standard. These tray slides also have the ability to hold one each 18" x 26" pans, for a total of five pans in place of the 12" x 20" x 2 1/2" pans.

| DIMENSIONAL DATA | RBC100 |
|---|-------------------|
| Net Capacity cu. ft. | 19.72 (557.5 l) |
| Number of Pans 12" x 20" x 2 1/2" | 10 |
| Max. Product Capacity lbs. | 100 (45.4 kg) |
| Length - Overall in. | 34 (86.4 cm) |
| Depth - Overall in. | 41 5/8 (105.7 cm) |
| Depth - Cabinet only in. Over Body in. | 36 (91.4 cm) |
| Depth - with Door Open 90° in. | 74 (188.0 cm) |
| Clear Door Width in. | 22 5/8 (57.5 cm) |
| Clear Door Height in. | 33 1/4 (84.5 cm) |
| Height - Overall on 6" Legs | 80 1/8 (203.5 cm) |
| ELECTRICAL DATA | |
| Voltage | 208-230/115/60/1 |
| Feed Wires with ground - without Plug | 4 |
| Full Load Amperes | 15.1 |
| Circuit Ampacity | 20 amp |
| Wattage 1 1/4 HP Blast Chill Compressor | 1690 |
| Wattage 1/2 HP Holding Compressor | 1165 |
| REFRIGERATION DATA | |
| Refrigerant | R404A |
| BTU/HR 1 1/4 HP Blast Chill Compressor | 5460 |
| BTU/HR 1/2 HP Holding Compressor | 2280 |
| Heat Load (chill compressor) BTU/HR | 12000 |
| Heat Load (holding compressor) BTU/HR | 5800 |

Figures in parentheses reflect metric equivalents

NOTE: Unit requires condensate removal via either a floor drain or optional electric condensate evaporator kit. See form TR35801 for more information.

NOTE: When ordering please specify: Voltage, Hinging, Options and any additional warranties.

Continued product development may necessitate specification changes without notice.
Part No. TR35798 (revised 4/10)

Blast Chill Operation

In Blast Chill mode both refrigeration systems, as well as two blowers are in operation. Cabinet air temperature can be as low as 0°F. The control closely monitors both the air and product temperatures to assure rapid chilling without freezing. The operator is notified upon completion of each chill cycle, and the unit automatically begins to maintain proper refrigerated storage temperatures. All chill cycle data is then stored in memory and can either be printed or downloaded to a PC on demand.

Controller

The patented SmartChill® microprocessor system operates using a familiar "ATM" type interface, providing for ease of training and use. The control allows the chiller to be operated in any one of three different chilling functions, and in any one of three modes. HACCP documentation is facilitated by two on-board printers which record all required product chill cycle information. This same data can also be downloaded to a PC using optional SmartChill® communications software (available from Traulsen) or via optional NAFEM Data Protocol Compliant hardware and software (by others). An instructional DVD is included.

Warranties

The unit is standard with a one year parts & labor warranty on all components and the cabinet, and an additional four year parts only warranty on the 1 1/4 HP Chill Compressor and 1/2 HP Maintenance Compressor. Additional warranties are available at extra cost.

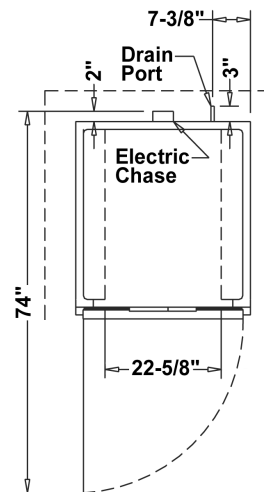
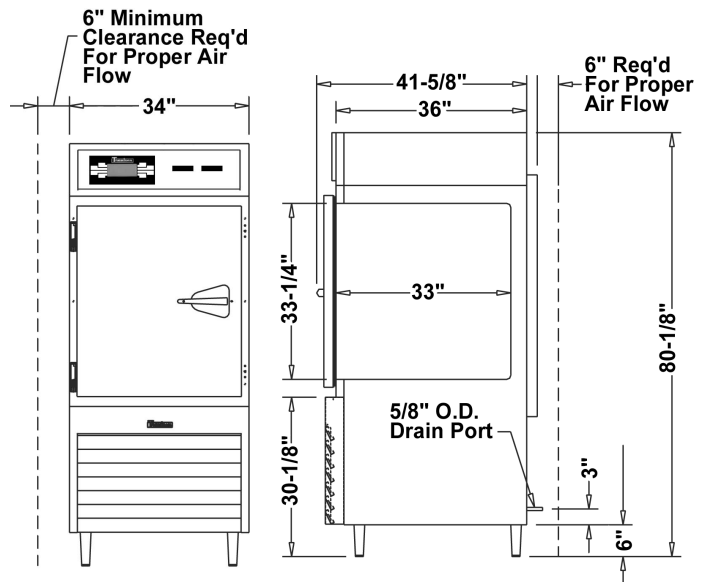

TRAUlsen
4401 BLUE MOUND RD.
PHONE 1 (800) 825-8220
Website: www.traulsen.com

FT. WORTH, TX 76106
FAX-MKTG. 1 (817) 624-4302

