

The Thermo Scientific SX30 combines patented dual frequency Doppler (DFD) technology with digital signal processing to create an industry leading measurement device for fluids that contain particulate. It is immune to higher levels of external noise than other single frequency Doppler devices, enabling the SX30 to operate in a broader range of applications.

## Thermo Scientific SX30

### Portable Dual Frequency Doppler Flowmeter



Thermo Scientific SX30 transducers feature stainless steel shrouds suitable for most pipe materials.



#### Applications

- Slurries
- Primary Sludge
- Dredging
- Activated Sludge

#### Accurate & Reliable

Dual Frequency Doppler (DFD) technology enables the Thermo Scientific SX30 to operate in what were previously considered marginal applications for Doppler flowmeters. Unlike conventional Doppler flowmeters, which operate at a single frequency, the SX30 generates two independent ultrasonic signals at different frequencies. By correlating these frequencies, the instrument identifies and eliminates noise errors from sources such as variable frequency drives.

#### Application Specific

The operation of the SX30 is enhanced by an Expert System which allows the flowmeter to automatically “learn” the application parameters. As a result, the SX30 can be setup in four easy steps and at a fraction of the time necessary to configure competitive flowmeters.

#### Durable & Easy-to-Use

The design features a sealed membrane keypad making the unit fully weatherproof. Large keys make it easy to enter data and navigate the on-screen menu—even with gloved hands.

#### Features & Benefits

- Accuracy to  $\pm 1\%$
- Simple and easy-to-use
- Excellent noise immunity
- IP66 environmental sealing
- Up to 24 hour battery operation
- Powerful 90,000 point data logger
- Serial interface port for data retrieval via HydraScan software
- Universal AC adapter charging socket

## Thermo Scientific SX30

### Performance Specifications

Velocity Range	0.06 m/s to 5.5 m/s (0.2 ft/s to 18 ft/s); volumetric value based on cross-sectional area of pipe
Accuracy	±1% of velocity full scale
Fluids	Liquids containing particulate entrained gas bubbles
Pipe Size	25.4 mm to 5 m (1 in to 200 in)

### Physical Specifications

Transmitter	IP66, waterproof against accidental immersion and splashproof with lid closed
Transducers	Encapsulated dual frequency sensor heads, encased in stainless steel shrouds with integral transducer clamps and BNC connectors 5 m (16 ft) cable - standard; 15 m (50 ft) cable - optional
Weight	Approximately 6.8 kg (15 lbs)

### Functional Specifications

Outputs	4-20 mA (into 750 ohms); 12-bit, 5 kV, opto-isolated, loop or self-powered; RS232 serial interface
Power Supply	Built-in lead acid gel battery 24-hour, continuous operation 90-264 VAC, 50/60 Hz 12-15 VDC auxiliary power port
Charge Period	8 hours
Keypad	21 key with tactile action
Display	Backlit, 240 x 60 dot, high resolution graphics display
Data Logger	90,000 point data logger Programmable in log intervals of 30 seconds or 1, 5, 15, 30 or 60 minutes HydraScan retrieval software for Windows® included as standard Compatible with Microsoft® Excel®, Lotus® 1-2-3 and other similar packages
Temperature Range	Transducers: pipe surface -40°C to +121°C (-40°F to +250°F); ambient air limited to +80°C (+176°F) Electronics: +5°C to +40°C (+41°F to +104°F), CSA approved; -20°C to +60°C (-4°F to +140°F), non-CSA approved
Compliance	Designed to meet CE and NRTL/C (CSA) for non-hazardous areas

### Thermo Scientific SX30 Dimensional Diagram

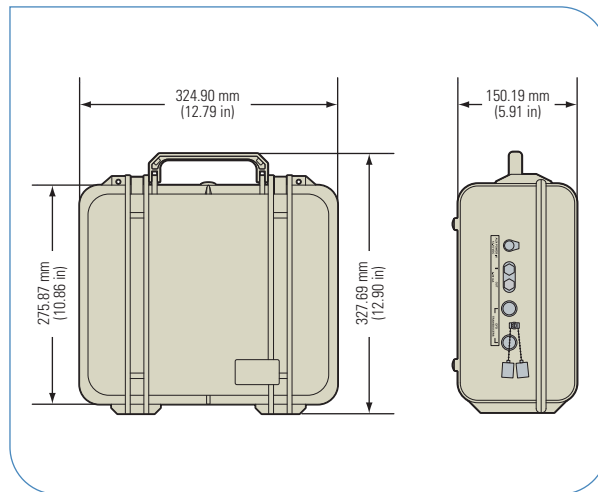

### Ordering Information

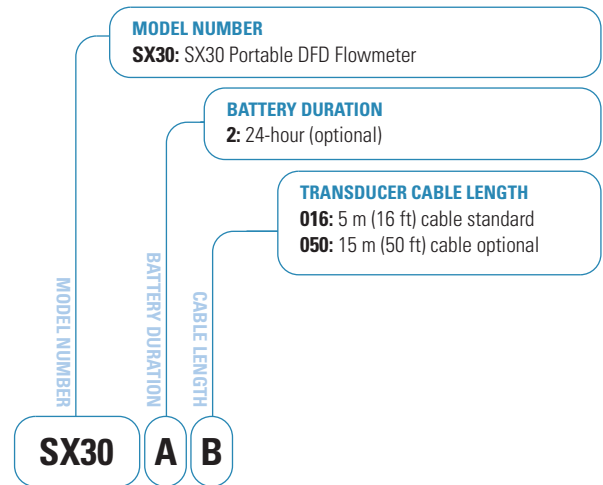

© 2009 Thermo Fisher Scientific Inc. All rights reserved. Lotus is a trademark of International Business Machines Corporation in the United States, other countries or both. Microsoft, Windows and Excel are registered trademarks of Microsoft Corporation in the United States and/or other countries. Results may vary under different operating conditions. Specifications, terms and pricing are subject to change. Not all products are available in all countries. Please consult your local sales representatives for details. Literature Code PL2011.0109

Room 1010 - 1019	+86 (10) 5850-3588
Ping'an Mansion No. 23 Jinrong Street	+86 (10) 6621-0847 fax
Xicheng Dist, Beijing 100032 CHINA	
A-101, ICC Trade Tower, Senapati Bapat Road	+91 (20) 6626 7000
Pune 411016 Maharashtra, INDIA	+91 (20) 6626 7001 fax
Ion Path, Road Three, Winsford	+44 (0) 1606 548700
Cheshire CW7 3GA UNITED KINGDOM	+44 (0) 1606 548711 fax
1410 Gillingham Lane	+1 (800) 437-7979
Sugar Land, TX 77478 USA	+1 (713) 272-0404
	+1 (713) 272-4573 fax