

The advanced Thermo Scientific SGD-O improves consistency, safety and overall performance by accurately monitoring fluid densities during fracturing and cementing. Backed by 30 years of experience with oilfield applications, this compact, rugged device is built to withstand high shock and vibration. It is also easy to install, simple to operate and has remotely-mounted electronics to ensure worker safety.

Thermo Scientific SGD-O

Non-Contacting Density Gauge for Fracturing and Cementing



Features & Benefits

- High pressure compatible detector; withstands 200x drop on concrete from 2 m
- Compact and lightweight
- Easy to install and use
- Resistant to high humidity
- Powered by readily available 12 or 24 volt power supply
- Electronic transmitter can be mounted up to 100 feet away from the gauge to ensure operator safety
- Quick disconnect connectors for cable and transmitters
- Minimal maintenance requirements

Endures High Shock and Vibration

Rapid response and high accuracy make the Thermo Scientific SGD-O the most reliable gauge for monitoring fluid densities, such as PPG, PPA and SGU, in the oilfield on fracturing and cementing sites. This unique gauge is engineered to endure high shock and vibration as well as withstand the extreme moisture and high humidity often found in oilfield environments.

Flexible and Responsive

During fracturing, the SGD-O enables operators to respond immediately to variations in slurry density and proppant concentration. It can be calibrated to allow for upstream and downstream monitoring, application to foam fracturing and the monitoring of any type of material, including sintered bauxite. This flexible gauge quickly converts from fracturing to primary or remedial cementing

applications to monitor cement density during pumping. Regardless of the application, it ensures all pre-programming is followed throughout the operation.

Non-Intrusive and Highly Accurate

Capable of measuring through any pipe thickness, the non-intrusive SGD-O is designed for varying oilfield environments. External materials that come into contact with the gauge will not affect its operation or reliability. To ensure consistency, the detector provides response in three to five seconds and accuracy to ± 0.1 pounds per gallon. The electronic transmitter can be mounted on a truck, control van or external control panel up to 100 feet away from the gauge, providing a safe method for monitoring results. In addition, an easy-to-use digital display and the flexible configuration ensure rapid field installation.

Principle of Operation

The SGD-O consists of three components: a source, a detector, and an electronics unit that incorporates the power supply and the signal handling and readout circuitry. The source is mounted opposite the detector at a convenient measuring point and emits low-energy gamma rays that pass through the pipe. These rays are absorbed by the fluid in the pipe in proportion to the material's density, with the remaining rays producing a signal inversely proportional to the density of the fluid running through the pipe. When the density decreases, the detector's signal increases. Measurement is constant. The continuous signal is relayed to the transmitter which provides a clear readout on a digital display that is preset to English or the metric system. With a response time of two seconds, operators can react quickly to any deviation in the predetermined density.

SGD-O Training

SGD-O operators are encouraged to take part in this hands-on lecture and lab course to gain insight on how to implement the gauge for maximum return on investment. Basic product application, installation procedures, programming, operation, maintenance and troubleshooting are covered in this fast-paced, one-day session. Contact us to learn more or visit www.thermo.com/processtraining for details.

Typical Low Pressure SGD-O Configuration

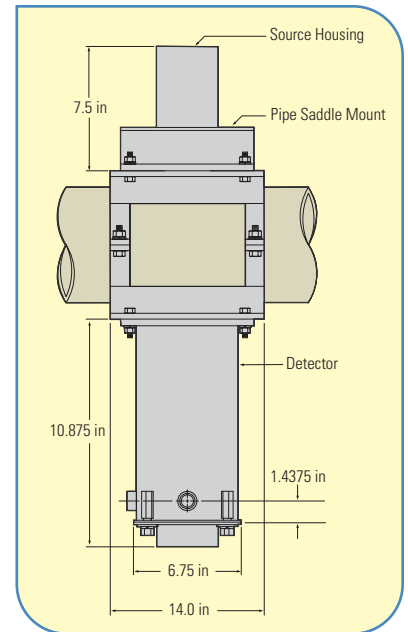

Thermo Scientific SGD-O

Gauge Specifications

Measurement Range	Cement: 0-28 PPG; Slurry: 0.8 to 2.8 SGU; Proppant concentration: 0-30 lb/prop/added/gal
Precision	±0.5 to ±0.1 lb/gal @ 8 lb/gal or ±0.006 - 0.012 kg/l @ 1 kl; dependent on pipe ID, source size and time constant
Accuracy	±0.1 PPG
Pipe Size	Low pressure pipe: 2.5 cm (2 in) to 25 cm (10 in); High pressure pipe: up to 20,000 psi/1,360.9 atm/1,379 bar
Power Requirements	12 to 24 VDC; 4VA
Output	4-20 mA; RS 485; RS 232
Shock/Vibration	Detector withstands shock of 200 drops from 2 m onto concrete; drops consistent with 100 in 1 azimuth followed by 100 drops in perpendicular azimuth
Operating Temperature	-50°C to +60°C (-58°F to +140°F)
Housing	Source head: Model 5190/5192; Detector: stainless steel 316 or carbon steel

Transmitter Specifications

Input	DC power: standard: 12 VDC (9-15V), 15 W; optional: 24 VDC (20-28V), 12 W AC power: optional: 110/220 VAC (100-240V), 50/60 Hz, 25 VA
Output	3.8-20.5 mA DC (adjustable operating range); configurable as: isolated, self-powered or isolated, loop-powered (user supplied 24 VDC loop power input); maximum load: 700 ohms
Serial Communications	RS232; 1 terminal block
Update Rate	4x per second
Connectors	Amphenol quarter turn bayonet style, jupiter or military-style cable available; quick disconnect oilfield rugged connectors
Operating Temperature	-40°C to +60°C (-40°F to +140°F)
Display	4 line, backlit LCD
Keypad	10 keys; external
Housing	Stainless steel 316
Mounting	Transmitter can be mounted 100 ft (30.48 m) from the detector

© 2008 Thermo Fisher Scientific Inc. All rights reserved. Results may vary under different operating conditions. Specifications, terms and pricing are subject to change. Not all products are available in all countries. Please consult your local sales representatives for details. Literature Code PI.2057.0308

14 Gormley Industrial Ave., Unit 4 Gormley Ontario L0H 1G0 CANADA	+1 (905) 888-8808 +1 (905) 888-8828 fax
Room 1010 - 1019 Ping'an Mansion No. 23 Jinrong Street Xicheng Dist, Beijing 100032 CHINA	+86 (10) 5850-3588 +86 (10) 6621-0847 fax
A-101, ICC Trade Tower, Senapati Bapat Road Pune, Maharashtra 411016 INDIA	+91 (20) 6626 7000 +91 (20) 6626 7001 fax
Ion Path, Road Three, Winsford, Cheshire, England CW7 3GA UK	+44 (0) 1606 548700 +44 (0) 1606 548711 fax
1410 Gillingham Lane Sugar Land, TX 77478 USA	+1 (800) 437-7979 +1 (713) 272-0404 +1 (713) 272-4573 fax