

Thermo Scientific Ramsey Model 90.125A Conveyor Weighing of Bulk Materials

The Thermo Scientific Ramsey Model 90.125A offers accurate weighfeeding of industrial materials at moderate feed rates. Its unique cantilevered and formed channel frame design provides a strong and sturdy weigh structure and allows for quick and easy maintenance. These features, along with your choice of several options, work together to augment the performance of your process and improve your bottom line.



Precise feeding of process materials is often critical to maintaining product quality. A feeder that weighs accurately and reliably can reduce material waste, help maintain blend consistency and increase profits.

We have well over 30 years of experience designing and manufacturing weighbelt feeders. Every feeder is designed to meet the specific needs of the application. We work closely with our customers to ensure that each system meets their expectations for performance and dependability.

The Thermo Scientific Ramsey Model 90.125A mid-range weighbelt feeder is designed for industrial weighfeeding applications with moderate feed rates and belt loading requirements. It accommodates flow rates of approximately 0.5 metric tons (0.5 tons) per hour up to 91 metric tons (100 tons) per hour, and belt loadings of 15 kg/m (10 lb/ft) to 170 kg/m (72 lb/ft).

Ramsey Model 90.125A Mid-Range Weighbelt Feeder**Theory of Operation**

Material is fed onto the feeder through an inlet feed section equipped with a manually adjustable vertical slide gate to control material height. The scale carriage/weighbridge assembly measures the gravitational force of the material and converts this force measurement into an electrical output signal proportional to belt loading.

A digital speed sensor continuously monitors the belt speed. The microprocessor-based electronics integrate the two signals to produce and display a true rate and a total weight fed. The electronics also provide an output signal for control and monitoring purposes.

For more information, refer to the separate product specification sheet on the Thermo Scientific Ramsey Micro-Tech 2000 or 3000 series of electronic integrators.

Features and Benefits

The Ramsey™ Model 90.125A mid-range weighbelt feeder incorporates our highly respected Thermo Scientific Ramsey Series 30 single-idler, pivotless weighframe for the accurate measurement of processed materials. Other special features and benefits include:

- **Cantilevered Frame:** This feature permits quick and easy removal of the feeder's vulcanized endless belts for cleaning, maintenance and belt replacement.
- **Formed Channel Frame:** This design feature provides a sturdy and rugged weigh structure for precise weighing.
- **Choice of Belt Widths:** This weighbelt feeder is available in four belt widths, from 457 mm (18 in) to 914 mm (36 in).
- **Various Feeder Lengths:** Customize your feeder length to fit your application, from 1,524 mm (5 ft) to over 4,572 mm (15 ft).
- **Construction Material:** Choose from carbon steel or stainless steel construction.
- **Speed Drives:** Choose from constant speed or variable speed drives.
- **Structure Design:** Choose from open, partially open, or fully enclosed designs.

Ramsey Model 90.125A Mid-Range Weighbelt Feeder — Schematic Diagram

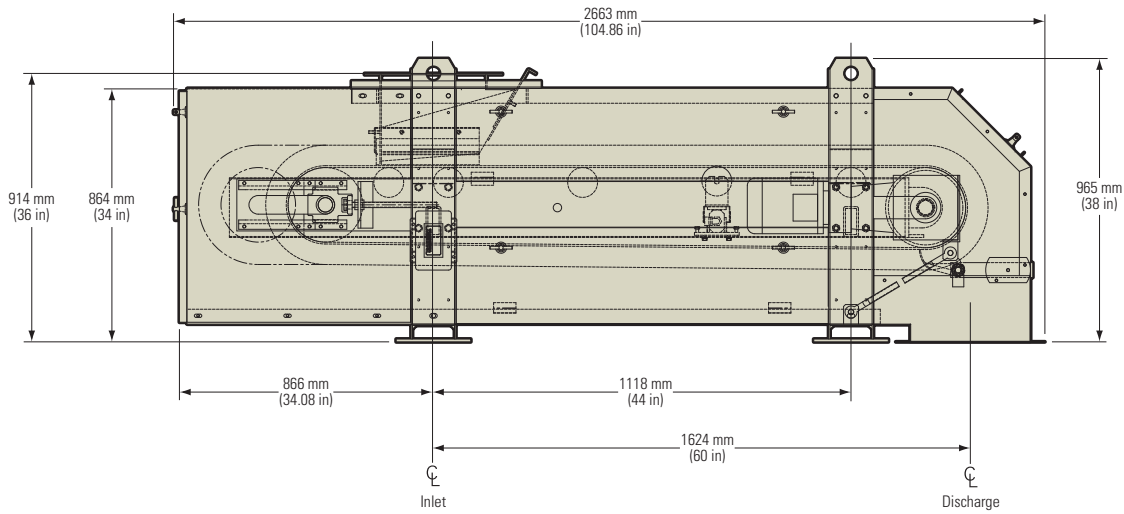

SIDE VIEW

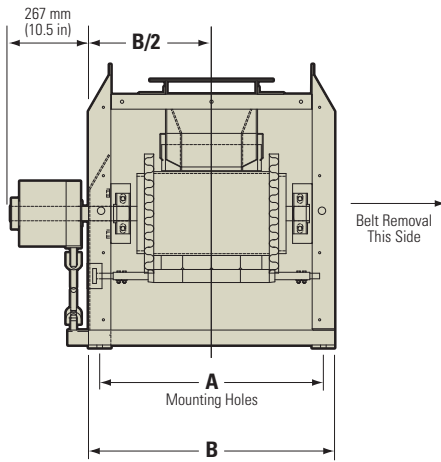

END VIEW

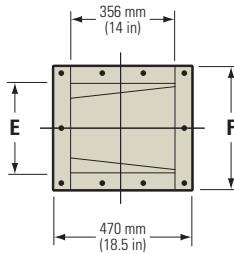

INLET FLANGE DETAIL

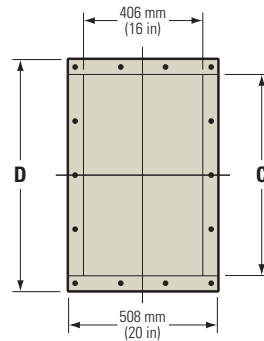

DISCHARGE FLANGE DETAIL

Ramsey Model 90.125A Mid-Range Weighbelt Feeder — Variable Dimensions

BELT WIDTH	LENGTH (mm)					
	A	B	C	D	E	F
457 mm	762	838	686	787	305	419
610 mm	914	991	838	940	406	521
762 mm	1067	1143	991	1092	508	622
914 mm	1219	1295	1143	1245	610	724

BELT WIDTH	LENGTH (in)					
	A	B	C	D	E	F
18 in	30	33	27	31	12	16.5
24 in	36	39	33	37	16	20.5
30 in	42	45	39	43	20	24.5
36 in	48	51	45	49	24	28.5

Thermo Scientific Ramsey Model 90.125A

General Specifications

Accuracy	±0.5% based on approved applications and test requirements
Belt Width	457 mm (18 in), 610 mm (24 in), 762 mm (30 in), 914 mm (36 in)
Feeder Length	1,524 mm (5 ft) to over 4,572 mm (15 ft) centerline of inlet to centerline of discharge
Feed Rate	0.5 metric tons/hr to 91 metric tons/hr at 801 kg/m ³ (0.5 ton/hr to 100 tons/hr at 50 lb/ft ³) material
Belt Load	15 kg/m to 107 kg/m (10 lb/ft to 72 lb/ft)
Weigh Span	457 mm (1.5 ft) typical
Belt	Endless polyester carcass belting with Grade 2 SBR covers suitable for most applications with corrugated sidewalls or 25.4 mm (1 in) vanner edges; Other belts available depending on application
Idlers	102 mm (4 in) diameter idlers rated CEMA C with sealed-for-life bearings; Larger sizes available depending on application
Head Pulley	254 mm (10 in) diameter, rubber lagged
Speed Reducer	Sumitomo or equal shaft mount; Other styles available
Scale Weighbridge	Unitized, single-idler, pivotless full-floating Ramsey Series 30 style platform scale system
Conveyor	Cantilevered frame for easy belt removal; Customer may specify belt removal on either the left or right side
Load Cell	Single platform type strain gauge transducer in compression
Load Cell Excitation	10 VDC recommended, 15 VDC maximum
Nonlinearity	<0.03% full scale
Repeatability	<0.02% full scale
Hysteresis	<0.02% full scale
Temperature Sensitivity	Zero: <0.0027% full scale/°C (<0.0015% full scale/°F) Span: <0.0014% of reading/°C (<0.0008% of reading/°F)

Digital Speed Sensor

Type	Digital, brushless
Mounting	Direct to shaft
Housing	Weather-tight

Options

- Top covers
- Side covers
- Bottom covers
- Scavenger clean-out
- Variable speed drives
- Flow/no-flow switches
- Run-off switches
- Safety pull switches
- Plugged chute switches
- Class 1 and 2 rated units
- Stainless steel construction
- Liners
- High temperature belts
- Shut-off/maintenance gates

© 2008 Thermo Fisher Scientific Inc. All rights reserved. All trademarks are the property of Thermo Fisher Scientific Inc. and its subsidiaries. Results may vary under different operating conditions. Specifications, terms and pricing are subject to change. Not all products are available in all countries. Please consult your local sales representative for details. Literature Code PI.8021.1108

	China	Netherlands	United States
	+86 (0) 21 6865 4588	+31 (0) 76-579-5555	+1 (800) 445-3503
	+86 (0) 21 6445 7830 fax	+31 (0) 76-571-4958 fax	+1 (763) 783-2525 fax
Australia	Germany	South Africa	+1 (763) 783-2500 direct
+61 (0) 8 8208 8200	+49 (0) 208-824930	+27 (0) 11-609-3101	
+61 (0) 8 8234 3772 fax	+49 (0) 208-852310 fax	+27 (0) 11-609-3110 fax	
Canada	India	Spain	
+1 (905) 888-8808	+91 (20) 6626 7000	+34 (0) 91-484-5965	
+1 (905) 888-8828 fax	+91 (20) 6626 7001 fax	+34 (0) 91-484-3597 fax	
Chile	Italy	United Kingdom	www.thermo.com/bulk-handling
+56 (0) 2 378 8050	+39 02-959514-1	+44 (0) 1788-820300	
+56 (0) 2 370 1082 fax	+39 02-953200-15 fax	+44 (0) 1788-820301 fax	