

The InScan X-ray inspection system is a safe, easy-to-use inspection solution for beverage filling lines. The InScan's patented, two-dimensional X-ray imaging software offers highly accurate fill measurement and quality control, ensuring maximum profitability for the user.

## InScan® X-Ray Inspection System

Inline Solution for Fill Level and Quality Inspection



Thermo Electron Corporation's InScan X-ray Inspection System is designed to control and optimize filling processes. The InScan uses non-ionizing, low power, X-ray technology to capture detailed images of the containers. The InScan's X-ray technology is non-irradiating and therefore safe to use.

The system utilizes multiple parameters to simultaneously inspect for product underfills, overfills, and missing or mis-applied closures at speeds up to 2,400 containers per minute with maximum accuracy. False rejects are significantly decreased due to the InScan's unique ability to differentiate between liquid and foam.

### Features

- Compact, cantilevered design for quick and easy installation
- $\pm 0.5$  mm Fill Level Accuracy
- Analysis up to 2,400 cpm
- Automatic Product Change-Over
- Image Provides Multiple Detection:
  - Fill Level/Net Content
  - Simultaneous Under & Over Fill
  - Liquid/Foam Differentiation
  - Pressure Detection
  - Missing or Mis-Aligned Lid/Cap/Crown
- Statistical Management Software Package
- A working environment free from radioactive gamma rays

### Accessories

- Adjustable, stainless steel stand

### Real-time, inline process control has distinct benefits:

- Brand protection by optimizing product quality
- Increased profitability with waste reduction
- Lower production and operation costs
- Improved line efficiencies
- Operator-safe technology
- Improved process control
- Low-cost of ownership

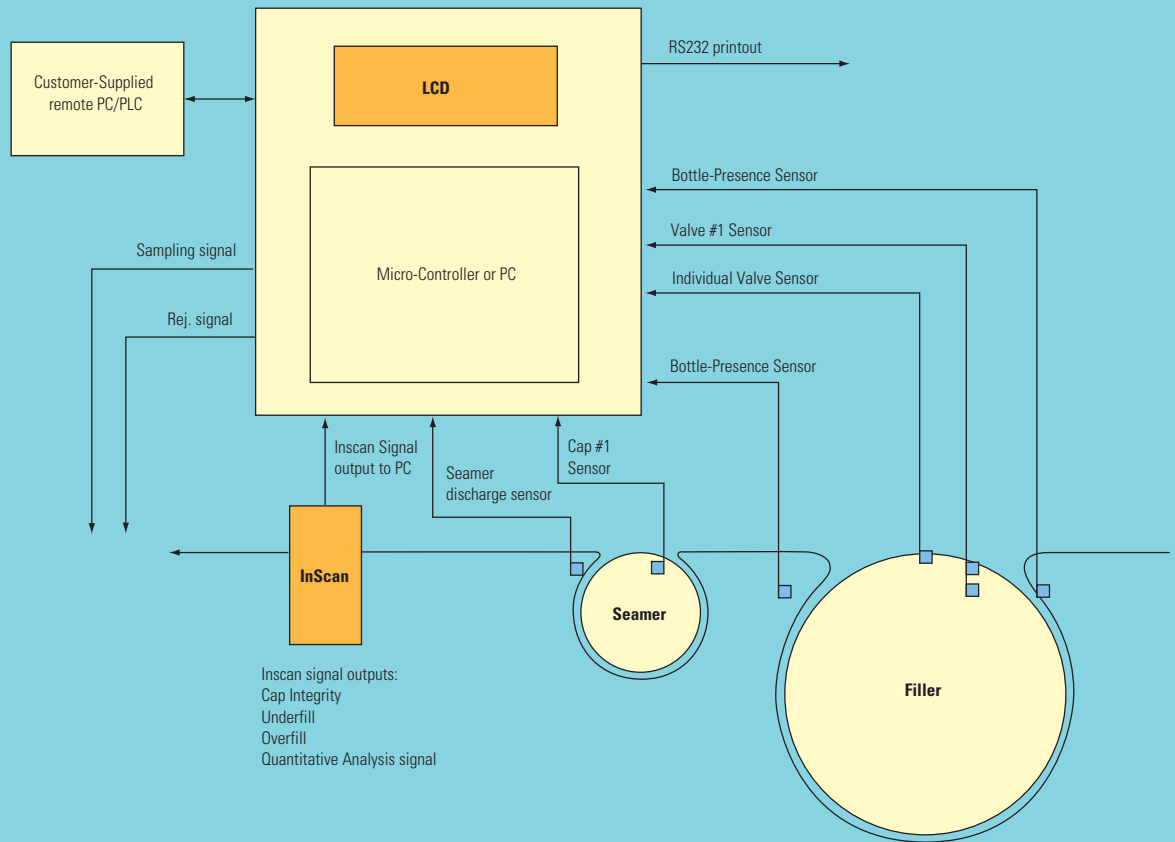

### Filler Valve Monitoring and Tracking System— Extending the Capability of the InScan System

The InScan's Filler Valve Monitoring (FVM) System is a cost-effective option that uses the information captured by the InScan system and synchronizes it to a specific filler valve. The FVM automatically detects potential fill-valve performance issues. This allows the user to achieve maximum production efficiencies and reduce waste by proactively managing the production line.

Using a network of sensors for filler-seamer/filler-capper synchronization and container tracking (see diagram above), the FVM can track containers from the InScan system point-of-inspection back to the specific filling head.

Operators are alerted to trends that could lead to costly shutdown of the filling line, giving them time to address faulty valves. Statistical records that are accessed via an optional color touch-screen allow the operator to monitor production efficiencies.

An automatic sampling feature allows the operator to select and reject containers from valves or seamer/capper heads for offline inspection. Containers are removed from the line at full production speed in order to maintain optimal line efficiency.

### Filler Valve Monitoring System

#### Standard Features

- Industrial microprocessor-based Filler Valve Tracking System
- 6-function key, LCD-graphic display (40 characters x 8 lines of text)
- Data downloading via serial interface
- Manual system-synchronization reset
- Stainless-steel NEMA 4 (IP65) housing

#### Optional Features

- Data Management and visualization via industrial PC with Pentium® MMX processor and Windows NT® Operating System
- 12-in, active TFT color display with touch screen
- External TFT display control panel kit for remote location install
- Container sampling module for selective removal of containers specific to value of seamer head.

### InView System Accessories

#### InView Stainless Steel NEMA 4 (IP65) Enclosure

The enclosure's mount provides pan, tilt, and roll axis motion, making it easy to precisely aim the camera. An opening at the rear of the enclosure allows the pass-through of standard cables without removal of cable connectors. The enclosure accommodates a variety of lenses. A number of accessories are included such as a pressure relief valve to allow air purging and cooling.

#### Camera Back Lighting

Acquiring high-quality images is an essential component of any successful machine vision application. The In-Sight sensors allow the user to choose from an array of high-performance light modules. Each light module provides superior illumination performance across a broad range of applications despite the ambient lighting conditions of your production environment, or the optical characteristics of the parts you are imaging. The light module's compact design allows them to be mounted just about anywhere on the production line. The backlight is housed in a NEMA 4 (IP65) protected housing for harsh environments.

#### In-View 1000 Breakout Box

Connects the camera system, power, I/O relays and serial devices to the InScan system.

### InView Cap Inspection System

The InView Cap Inspection system is an accurate, cost-effective cap inspection solution. The InView system rejects containers with non-conforming closures, avoiding costly stops in down stream production. It also prevents leaking, misaligned caps from reaching the consumer market. The user-friendly software ensures quick, error-free setup with minimal training or application knowledge. A simple graphical user interface is just one of the many advantages of the InView cap inspection system.

### InScan X-Ray Inspection System

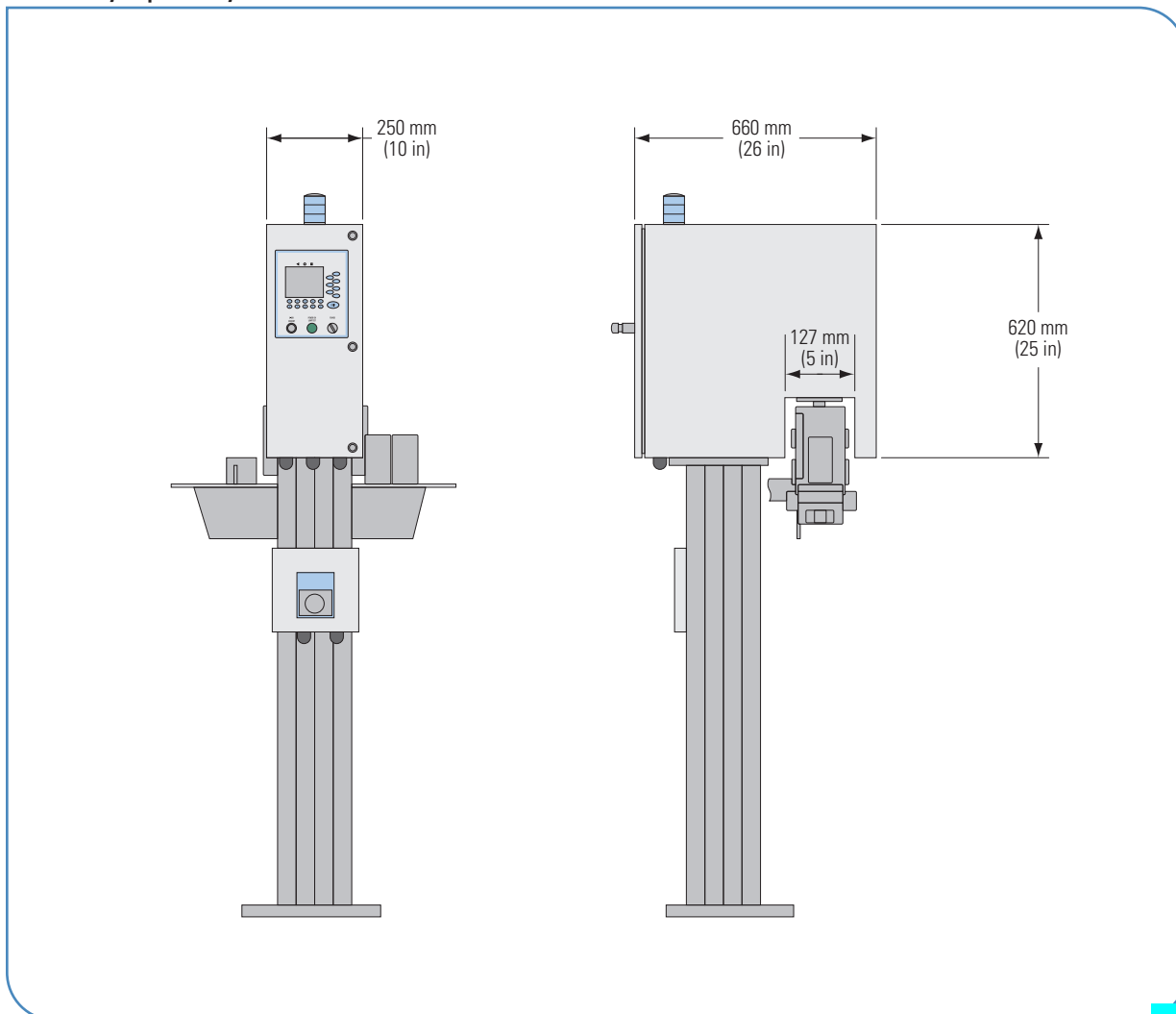

## InScan X-Ray Inspection System

Specification	
<b>InScan X-Ray Fill-Level System</b>	
Source	Low dose X-ray
Inspection Rate	Up to 2,400 containers per minute; 160 m per minute (520 ft per minute)
Container Type	Aluminum; steel; glass; plastic
Fill Volume	±0.5 mm fill level resolution
Pressure	Dud/No Dud
Power	110/220 VAC, 50/60 Hz, 15 Amps
Temperature	5°C to 50°C (41°F to 122°F)
Humidity	0% to 95% non-condensing
Output	RS232C (ModBus); 8 isolated relays including a reject control output
Dimensions	InScan chassis: 620 mm (25 in) high x 250 mm (10 in) wide x 660 mm (26 in) deep
Mounting	Floor mounted
Rejector	Optional ram, upright, and air rejector systems available
Safety	Completely safe for operations and product; Complies with all relevant international electrical, mechanical and radiation safety regulations
Code Compliance	Meets CE and complies with FDA CFR 21 component parts 1000-1005.
<b>Filler Valve Monitoring System</b>	
Source	Low power X-ray tube
Detector	Production array
Inspection Rate	2400 cpm
Power	110/220 VAC 50/60 Hz, 15 A
Temperature	5°C to 50°C (41°F to 122°F)
Humidity	0% to 95% non-condensing
Output	RS232 (Modbus), 24V
Display	Illuminated LCD graphic (optional Color TFT)
Dimensions	InScan chassis: 620 mm (25 in) high x 250 mm (10 in) wide x 660 mm (26 in) deep
Dimensions	InScan: 620 mm (25 in) high x 250 mm (10 in) wide x 660 mm (26 in) deep FVM Enclosure: 250 mm (10 in) high x 410 mm (16 in) wide x 360 mm (14 in) deep
Mounting	InScan: Floor FMV: Floor
Rejectors	Optional ram, upright, and air rejector systems available

©2004 Thermo Electron Corporation. All rights reserved. Specifications, terms and pricing are subject to change. Not all products are available in all countries. Please consult your local sales representatives for details. Pentium is a registered trademark of Intel Corporation. Windows is a registered trademark of Microsoft Corporation. All other trademarks are the property of Thermo Electron Corporation and its subsidiaries.  
Literature Code PL.0020.0804

Argentina +54 (0) 11 4 334 3827 +54 (0) 11 4 334 9159 fax	Germany +49 (0) 208-824930 +49 (0) 208-852310 fax	Poland +48 (0) 22848 3708 +48 (0) 22848 3708 fax
Australia +61 (0) 8 8150-5300 +61 (0) 8 8234-5882 fax	India +91 (0) 20-4011245 +91 (0) 20-26125739 fax	South Africa +27 (0) 11-609-3101 +27 (0) 11-609-3110 fax
Canada +1 (905) 888-8808 +1 (905) 888-8828 fax	Italy +39 0521 78861 +39 0521 272914 fax	Spain +34 91-484-5949 +34 91-661-5572 fax
Chile +56 (0) 2-335-3388 +56 (0) 2-335-1590 fax	Malaysia +60 (0) 3 2300 1626 +60 (0) 3 2300 1636 fax	United Kingdom +44 (0) 1788-820300 +44 (0) 1788-820301 fax
China +86 (0) 21 5465 7588 +86 (0) 21 6445 7830 fax	Mexico +52 (01) 55 5638 0237 +52 (01) 55 5639 2227 fax	United States +1 (877) 290-7422 +1 (763) 783-2525 fax
France +33 (0) 1 60 92 48 00 +33 (0) 1 60 92 49 00 fax	Netherlands +31 (0) 33-454-9000 +31 (0) 33-454-9009 fax	

Process Instruments