

The Thermo Scientific CB Omni online elemental analyzer provides a reliable and accurate means of achieving consistent stockpile and raw mix chemistry to improve kiln efficiency and minimize production costs. This unique system provides minute-by-minute composition analysis of the raw materials used in the cement manufacturing process.

## Thermo Scientific CB Omni

### CrossBelt Online Elemental Analyzer



#### Benefits

- Delivers consistent clinker quality
- Increases kiln throughput
- Reduces kiln upsets
- Reduces energy consumption
- Extends refractory life
- Extends quarry life
- Minimizes use of highest cost, most expensive materials



#### Features

- Modular design for ease of installation
- Modules moveable without need of equipment
- Fits onto existing conveyor truss without needing to cut the conveyor support structure
- Reduced installation costs and requirements
- Belt widths from 0.6 m (23.6 in) to 2.2 m (86.6 in)
- Variable tunnel heights to accommodate process conditions
- Enhanced performance
- Superior, robust accuracy (ABLC)
- State-of-the-art electronics
- Flexible plant connectivity
- Comprehensive user interface

The Thermo Scientific CB Omni is a Prompt Gamma Neutron Activation Analysis (PGNAA) system designed to integrate into either a new or an existing conveyor belt line and analyze, in real time, the composition of raw materials being transported by conveyor belt. The system analyzes the entire material stream and is not subject to errors and costs associated with material sampling.

The CB Omni uniquely combines the best technology from two industry-leading PGNAA instrument suppliers. When Thermo Fisher Scientific (known then as Thermo Electron Corporation) acquired the former ASYS organization in September 2006, the best and most innovative technology from both groups was identified and implemented into the CB Omni. The result is a unique system that provides unparalleled ease of installation, performance and reliability for raw material analysis and control.

The CB Omni takes modular design to the next level making it one of the easiest and most flexible cross-belt analyzers to install. The newly designed modules can be individually transported and moved without the use of equipment. In addition to this, the overall system when fully assembled is smaller than previous versions, enabling installation into locations with limited clearance. The analyzer can also be installed onto the existing conveyor without needing to cut and remove the conveyor line support structure or electrical conduits.

#### Applications

Thermo Scientific cross-belt analyzer systems are typically used in the following applications at cement plants throughout the world:

- Pre-blending stockpile control
- Raw mix proportioning control
- Material sorting

### Pre-Blending Stockpile Applications

One of the most popular uses of cross-belt online analysis systems is controlling stockpile chemistry to meet quality targets, thus ensuring smooth kiln operation and providing flexibility in quarry operations. Whether the stockpile is longitudinal or circular, the CB Omni allows the cement producer to achieve consistent stockpiles, with minimal variations within and between piles.

Using optional software, quality control can be accomplished either automatically or with a person in the loop (manually). In either case, the analyzer tracks the chemistry of the stockpile compared to the target chemistry and determines the preferred proportions of the source raw materials.

### Raw Mix Proportioning Applications

A primary determinant of kiln efficiency is the chemical uniformity of kiln feed. Kiln feed uniformity is in turn derived from the precise control of raw mix. Located downstream of the last raw mix component addition, a CB Omni system provides the precise control needed to minimize raw mix variability while at the same time minimizing raw material costs and satisfying multiple quality control targets.

Using optional software, raw mix proportioning can be accomplished automatically with the system's analysis triggering proportioning changes as frequently as each minute. The optional software accounts for varying time delays from the feeders to the analyzer and can accommodate multiple raw mix sources and

### The CB Omni: The Best of the Best

The combined expertise of Thermo Fisher Scientific (formerly known as Thermo Electron Corporation) and the ASYS product line we acquired brings the most advanced and flexible technologies to your process.

- Revolutionary detector design with improved efficiency and flexibility in number and position
- Easy to install-takes modularity to the next level with no need to cut belt line and components that do not require lifting equipment
- Mounts directly on conveyor line
- Adaptable to all belt sizes and material types
- Superior accuracy owing to calibration methods, spectral analysis process, latest generation electronics and ABLC
- Experienced service organization located throughout the world
- Applications expertise coupled with proven optimization software and highly popular user interface

control parameters. The control algorithm utilizes material cost minimization and allows the user to define priorities among the different control parameters.

### Material Sorting Applications

In many cases, a production plant process may require that its raw materials be sorted based on material composition. The CB Omni is perfectly suited for this type of work and rapidly determines when a material composition changes.

Optional software can automatically send a signal to a flop gate or traveling overhead tripper to place material in a location based on its composition.

### The CB Omni: The Best of the Best

The CB Omni analyzer is designed for peak performance with maximum flexibility and reduced installation costs.

### Easily Integrates into the Conveyor Line

The CB Omni's steel framework sits on and integrates with the conveyor line's existing support structure. In other words, a belt line does not need to be cut to install a CB Omni. This is a significant difference from all previous generation online analysis systems for conveyor belts, and this new design minimizes installation complexity and costs. The CB Omni fits cleanly onto a conveyor belt line with few modifications and existing steelwork and catwalks are generally not adversely affected. Furthermore, clearance requirements between the delivery and return strand of the conveyor are minimized, such that bend pulleys used to clear the lower part of the system may not be required.

### Analysis Zone Configuration—Tunnel Height, Width and Detector Position

- System accommodates all material profiles and processes
- Tunnel width and height optimized per application
- Adjustable detector position allows optimization to specific application
- Multiple detector option allows for optimized performance per application

CB Omni CrossBelt online elemental analyzer



### Automatic Belt Load Compensation (ABLC)

The CB Omni incorporates the unique Automatic Belt Load Compensation feature which ensures analyzer accuracy over a range of changing production rates and belt loading. As the material loading on the belt decreases, the background signal from elements in the conveyor itself grows accordingly. If not accommodated this would cause the analyzer to be inaccurate. The unique ABLC feature ensures that the system stays accurate no matter what loading conditions are encountered.

### Information Exchange and PC Interfaces

Integration of an online analyzer into a cement production line generally requires a communication interface with a plant control network. The CB Omni is extremely flexible in this regard and is compatible with most major communication protocols. The most popular protocol in use today is OPC. The system configures easily as either an OPC Server or an OPC Client.

### Remote Diagnostics and Assistance

All Thermo Scientific online analyzers are equipped with the capability to connect to the system from one of our service centers in order to provide rapid interactive assistance. The connection is made either via the World Wide Web or through a dedicated telephone connection.

### Analyzer Components

The CB Omni analyzer system consists of four major subassemblies:

#### Analyzer Assembly

A unique modular assembly and frame easily mounts onto an existing conveyor belt line without cutting the conveyor structure. The analyzer assembly contains the detection and measurement mechanics of the system.

#### Electronics Module

Advanced, high-speed digital electronics control, process, monitor and exchange information between the Analyzer Assembly and the Operator Console.

#### Operator Console

The Thermo Scientific Operator Console is the user interface for the CB Omni system. The OpCon utilizes the Thermo Scientific standard Base Cement software package that provides analysis data on minute-by-minute, rolling average and interval average basis; product tracking capabilities; extensive graphic functionality; alarms; and the ability to transfer data to control systems over an OPC link or by .csv spreadsheet files. Optionally, the OpCon can be coupled with process control software that allows either automatic or manual control of pre-blending stockpiles or raw mix proportioning circuits. Each OpCon has the capability for remote connection through a telephone connection or through the internet for minor repair and troubleshooting.

#### Reference Standards

Unique modular reference standards are used to qualify and monitor system performance.

### Analysis Capabilities

#### The CB Omni system measures and reports the following

- SiO<sub>2</sub>
- Al<sub>2</sub>O<sub>3</sub>
- Fe<sub>2</sub>O<sub>3</sub>
- CaO
- MgO
- K<sub>2</sub>O
- Na<sub>2</sub>O
- SO<sub>3</sub>
- TiO<sub>2</sub>
- Mn<sub>2</sub>O<sub>3</sub>
- Cl
- Moisture (optional)

#### The CB Omni computes the following

- Lime Saturation Factor
- Silica Ratio
- Alumina—Iron Ratio
- Loss On Ignition
- C3S
- C2S
- C3A
- C4AF
- Total Alkali
- Percent Liquid
- Burnability Index
- Burnability Factor
- Custom Quality Formulas (customer defined)

### CB Omni operational diagram

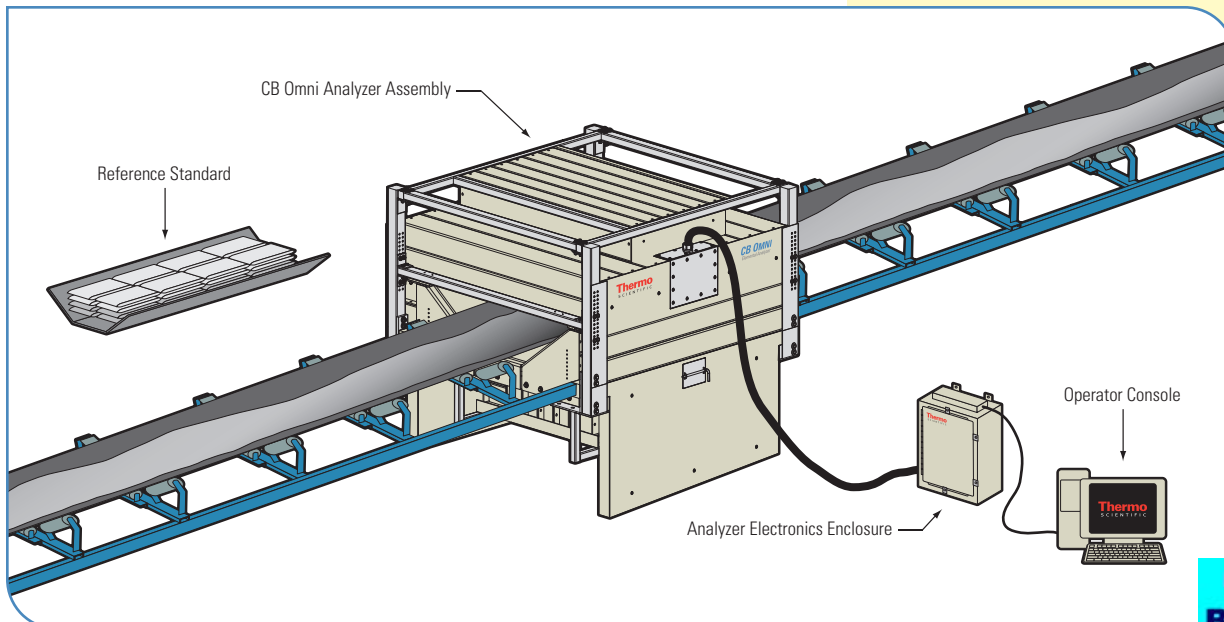

## CB Omni

### Specifications

Belt Size	600 mm (24 in)	800 mm (30 in)	900 mm (36 in)	1000 mm (42 in)	1200 mm (48 in)	1400 mm (54 in)	1800 mm (72 in)
Length of Unit	2103 mm (79 in)	2103 mm (79 in)	2103 mm (79 in)	2103 mm (79 in)	2103 mm (79 in)	2103 mm (79 in)	2103 mm (79 in)
Width	1690 mm (67 in)	1690 mm (67 in)	1975 mm (78 in)	1975 mm (78 in)	1975 mm (78 in)	2133 mm (84 in)	2337 mm (92 in)
Approximate Height	1575 mm (62 in)	1575 mm (62 in)	1689 mm (67 in)	1689 mm (67 in)	1689 mm (67 in)	1905 mm (75 in)	2068 mm (81 in)
Weight	2721 kg (6000 lb)	2721 kg (6000 lb)	2964 kg (6535 lb)	2964 kg (6535 lb)	2964 kg (6535 lb)	3365 kg (7200 lb)	4081 kg (9000 lb)

### Standard Physical Specifications

Troughing Angle	35°
Electronics Enclosure	NEMA 4 enclosure 762 mm tall x 610 mm wide x 305 mm deep (30.00 in tall x 24 in wide x 12.00 in deep)
Electronics Connection to Analyzer	Standard 25-meter or 50-meter cable provided; Configurable on request
Operating Temperature	-30°C to +50°C (-22°F to +122°F)

### Electrical Specifications

Electronics Enclosure	230 VAC 50 or 60 Hz, 7 Amps 3 wire (L1, N, GND)
Operator Console	120 VAC 50 or 60 Hz, 5 Amps 1 Phase or 230 VAC 50 or 60 Hz, 2.5 Amps 1 Phase

### Communications

Electronics Enclosure to Operator Console (Customer Supplied)	Fiber Optic 62.5/125 multimode (minimum of 2 fibers) 2000 meters maximum (longer distances optionally available) or Optional wireless data communication package (Thermo Scientific Wireless Xpert)
Operator Console to Customer	OPC client/server link, major communication protocols, ODBC
Control System (Customer Supplied)	
Offsite (Remote) Communication	One data quality phone line or internet link required
Isotope	Cf-252 Neutron source; Amount defined per application and performance requirements

©2007 Thermo Fisher Scientific Inc. All rights reserved. All trademarks are the property of Thermo Fisher Scientific Inc. and its subsidiaries. Results may vary under different operating conditions. Specifications, terms and pricing are subject to change. Not all products are available in all countries. Please consult your local sales representatives for details. Literature Code PI.0049.0507

Americas  
+1 (800) 488-4399  
+1 (858) 452-9250 fax

Australia  
+61 (0) 2 8844-9500  
+61 (0) 2 8844-9555 fax

Europe  
+49 (0) 6104 923680  
+49 (0) 6104 923682 fax

South Africa  
+27 (0) 11-609-3101  
+27 (0) 11-609-3110 fax

Asia  
+60 (3) 7728 2100  
+60 (3) 7728 2991 fax

China  
+86 (0) 21-6865 4588  
+86 (0) 21-6445 1101 fax

India  
+91 (20) 6626 7000  
+91 (20) 6626 7001 fax

[www.thermo.com/cement](http://www.thermo.com/cement)