



THERMAL CARE
7729 N. Lehigh Ave.
Niles, IL 60714-3491

Phone: (847) 966-2260
Fax: (847) 966-9358

SF Series Screen Filter OWNER'S MANUAL OPERATION AND INSTRUCTION GUIDE

Record in the space below the Serial # of your unit

Serial # _____

The Serial # is located on the top of the outlet flange or pipe.

IMPORTANT

Please make certain that persons who are to use this filter thoroughly read and understand these instructions prior to operation. Should you have any questions regarding the operation of this filter, please call (847) 966-2260 and ask to speak with one of our customer service representatives.

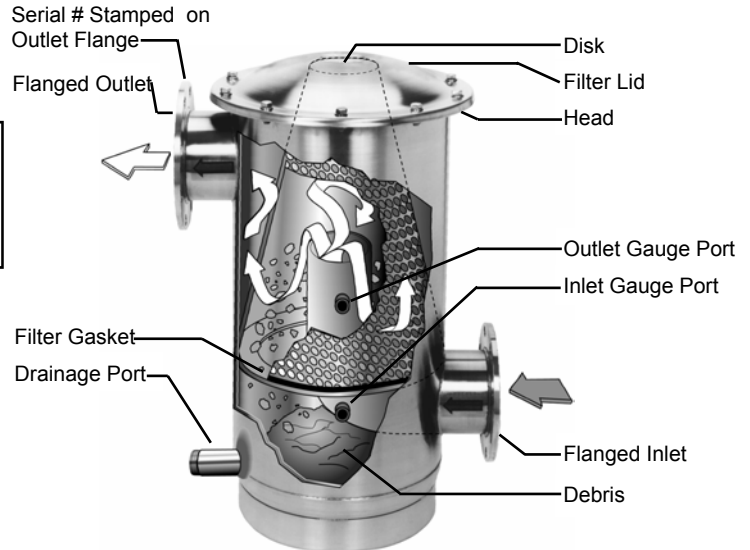

I. SAFETY CONSIDERATIONS

Safety precautions are essential when any filtration equipment is involved. These precautions are necessary when using, storing, and servicing your filter. If safety precautions are overlooked or ignored, personal injury or product damage may occur.

Your filter was designed for specific applications. It **should not** be modified and/or used for any application other than originally specified. If there are any questions regarding its application or installation, contact Thermal Care, Inc.

Always heed the following precautions, as they are essential when using your SF Series Screen Filter.

- 1) Read this manual carefully. Consider the applications, limitations, and the potential hazards specific to your filter.
- 2) (Flanged units only) The filter must be placed on a firm, supporting surface. The filter **should not** be suspended by the inlet and outlet flanges.
- 3) Absolutely under no conditions should the filter lid or pressure gauges be removed while the filter is pressurized. Standard bolted lid models should never exceed 150 PSI; V-Band clamp models should never exceed 125 PSI.
- 4) Units with damaged or missing parts should **never** be operated. Contact our customer service representatives for replacement parts.
- 5) Back-flow prevention devices should be installed upstream of the inlet and downstream of the outlet of the filter as to prevent back flow or vacuum effects which may be damaging to the filter element.
- 6) Pressure relief valves of a sufficient size and volume should be installed upstream of the inlet and downstream of the outlet of the filter. They should be set to relieve pressure at 1.2 times the maximum operating pressure (not to exceed the max. rated pressure). This helps prevent damage to the filter and element if severe stoppage or water hammer occurs.

AT NO TIME SHOULD THE INTERNAL PRESSURE EXCEED THE MAXIMUM RATED PRESSURE FOR YOUR FILTER

II. BEFORE FILTER OPERATION

There are a few tasks that must be accomplished before your SF Series Screen Filter is ready for operation. Please review the following checklist. When all tasks are complete the filter is ready to be used.

1. (Flanged Units Only) Is your SF Series Screen Filter placed on a firm, supporting surface? Failure to do this may cause stress on the weld joints. Thermal Care recommends a concrete pad be poured under the base of the filter.
2. Are the inlet / outlet connections securely fastened to the in-line pipe? The arrows clearly depict flow direction (see above).

3. Have you installed a check valve/back flow prevention device upstream of the inlet and downstream of the outlet of the filter so as to prevent back flow or vacuum effects which may be damaging to the filter element?
4. Have you installed a quick-pressure relief valve upstream of the inlet and downstream of the outlet of the filter; set to relieve pressure at 1.2 times the maximum operating pressure (not exceeding the maximum rated pressure of your filter)? This is to prevent damage to the filter element when and if severe clogging or water hammer occurs. Pressure relief valves are available in various sizes consult your local dealer or valve manufacturer to obtain the proper valve for your application.
5. Have you installed a valve on the drainage port located at the bottom of the filter body (see front cover diagram)? This valve, when opened, will allow debris to escape the filter body.
6. Make sure back-mount pressure gauges are installed in the gauge ports located on the front of the filter body (see front cover diagram). These gauges will allow you to monitor the pressure differential on each side of the screen so as to know when and if the filter element is clogging.
7. Is the SF Series Screen Filter lid securely fastened? Each bolt should be tightened to ensure safety and an adequate seal.

III. TORQUE SPECIFICATIONS

BAND CLAMP MODELS: (SF-2, SF-3, and SF-4C)

The over-center latch clamp is used on the SF-2, SF-3, and SF-4C units and is installed by placing the clamp around the filter, latching the T-bolt with the receiver, and pushing the latch handle towards the filter body until the safety catch engages. The over-center clamp does not require adjustment to be installed and removed. The lock washer is set at the factory for proper clamp compression and normally requires no field adjustment. Minor tightening may be necessary over time. (SEE TABLE BELOW)

NOTE: The SF-4 filter is available with both a bolted lid and clamped lid. These are differentiated by a “B” for the bolted lid and a “C” for the clamped lid model.

BOLTED LID MODELS: (SF-4B, SF-6, SF-8, SF-10)

The bolted lid SF Series Screen Filters require that the attachment bolts be tightened sufficiently to make a complete seal without damaging the bolts or the filter head. Grade 5 Zinc plated bolts, nuts and washers are used to attach the heads to these filters. The size and recommended torque of the bolt is dependent on the filter size. The following table shows the bolt size and torque rating for each filter.

FILTER	BOLT SIZE	RECOMMENDED TORQUE
SF-2 (Clamp)	5/16" - 18	40 – 50 in. lbs.
SF-3 (Clamp)	5/16" - 18	60 –80 in. lbs.
SF-4C (Clamp)	5/16" - 18	75 – 85 in. lbs.
SF-4B	3/8" - 16	15 – 25 ft.lbs
SF-6	1/2" - 13	45 – 55 ft.lbs
SF-8	1/2" - 13	45 – 55 ft. lbs.
SF-10	5/8" - 11	80 – 100 ft. lbs.

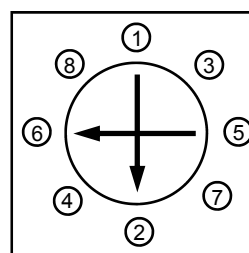

Recommended Torquing Sequence

It is important to follow the torque specifications as over-torquing may result in premature failure of the bolt. Another important procedure when tightening the bolted lid is to follow a star wheel torque pattern (see above right). This is similar to the tightening of an automobile wheel in that the next bolt to be tightened is located opposite to the bolt just tightened. Most likely the filter lid will not seat down completely after one series of torquing, this is especially evident on the larger filters (SF-8 and larger). A second tightening of the bolts should seat the lid securely to the body. On SF-8 and SF-10 models a 1/8 inch lid ring can be seen and should rest flush against the body flange when the head is properly tightened. The SF-4B and SF-6 lids also have this ring but it is hidden by the edge of the head. The SF-4B and SF-6 heads will seat completely after two torquing sequences.

IV. FILTER OPERATION

At this point the SF Series Screen Filter is ready for operation. Periodically (depending on liquid quality) the debris that settles out at the bottom of the filter will need to be flushed out. The drainage port located at the bottom of the filter is what makes this possible. Upon receiving your filter, you must install a valve on the drainage port. It is the user's discretion how often the valve should be opened. It strictly depends on how much debris is being captured by the screen and falling into the filter reservoir. Over time, one should be able to accurately determine how often the valve should be opened. **It is important that you never allow debris to accumulate beyond the capacity of the reservoir.**

Larger series filters (SF-4, SF-6, SF-8, SF-10) are equipped with a flush port extension inside the filter to allow for a nearly complete cleaning of the filter reservoir every time the filter is flushed. The drainage port valve should be opened while the filter is in operation. Flow rate and pressure determine how long the valve should be open to flush the debris from the filter tank. A good rule of thumb is to leave the valve open until the liquid being expelled flows free of debris. This should take from 30 to 60 seconds depending on the flow, pressure, and amount of debris.

Larger filters require higher flushing pressures to achieve complete cleaning: the SF-4 can be flushed as low as 15 - 20 PSI; the SF-6 can be flushed as low as 30 - 35 PSI; and the SF-8 and SF-10 should be flushed at 40 PSI or greater if possible.

(Note: After operation, open the drainage port to allow the water contained in the filter body to drain. If there is corrosive chemical content in the water, it may corrode the filter element. Also, in winter months, the water may freeze and expand putting unnecessary stress on the filter body).

V. FILTER ELEMENT CLEANING

The pressure gauges that you have the option of installing can be used to monitor the pressure differential between the inlet and outlet sides of the filter. When there is a pressure loss of 5-10 PSI between the inlet and outlet side of the SF Series Screen Filter, the filter element may require cleaning.

CAUTION: Make sure that the system is completely shut down when the filter element is to be taken out and cleaned. NO pressure should remain in the system.

Follow these steps when cleaning the SF Series Screen Filter element:

Step 1: (Bolted Lid Models) Remove the top of the SF Series Screen Filter by removing the Grade 5 Zinc plated bolts from the lid.

Step 1: (Band-Clamp Lid Models) Remove the top of the SF Series Screen Filter by taking off the band-clamp assembly.*

Step 2: Lift the filter element (conical screen) out of the filter body.

Step 3: Carefully scrub down the filter element with a rigid nylon brush until all matter is loosened.

Do not use a steel brush.

Step 4: Wash the filter element off with clean water. It is preferred to use a hose with a significant amount of water pressure.

Do not use a pressure washer.

Step 5: Wash all matter from the filter gaskets and clean the inner-ring where the bottom of the filter element rests.

Step 6: Make sure the U-shaped gasket is fitted securely to the bottom of the filter element. Reposition the filter element into the body of the filter.

Step 7: Make sure the filter head gasket is secure on the top of the filter body. On V-Band models, O-rings should be seated completely in the body flange. Reposition the filter lid back on the filter body. *Tighten the lid securely either with the bolts or with the band-clamp.*

* For band-clamp models, opening and closing is achieved without adjusting the lock nut. It is tightened at the factory to the correct compression. (Minor tightening may be necessary if the gasket loses memory over time). To open the clamp, depress the safety latch and pull the over-center lever outward. To close the clamp, make sure the T-Bolt is seated in its receiver and push the over-center lever back toward the filter housing. *Be sure that the safety latch is engaged before putting the unit to use.*

VI. INFORMATION CONCERNING WATER HAMMER

WHAT IS WATER HAMMER?

Water hammer is a phenomenon that can occur in fluid systems with long pipes between the fluid source and the outlet. The term itself refers to the sound made when water hammer occurs which resembles banging a hammer on a long pipe. Water hammer is a rapid change of pressure caused by a rapid change in velocity. When the velocity is changed a pressure wave that travels at the speed of sound is initiated and travels in the upstream direction until it reaches some stationary energy level, like a reservoir. A rarefaction wave (at the pressure of the water source) then travels downstream at the same speed. If the flow has been shut off downstream the pressure wave impacts the blockage and the pressure in the entire system is raised very quickly.

WHAT CAUSES WATER HAMMER?

Any action that can cause a rapid change in the velocity of the flow can set off a water hammer - closing a downstream valve, pipe fracture, pump stoppage, etc. The critical time for which a valve may be closed depends on the length of piping between the valve and the source reservoir. The longer the distance the slower the valve may be shut to cause a water hammer. Typically for short lengths of pipe (below 500 ft) the critical time is less than 1/10 second.

WHAT CAN WATER HAMMER DO?

Pressure spikes from water hammer can raise fluid pressures to very high values (in excess of 1000 PSI depending on the situation). Such pressure spikes can result in mechanical failures such as broken valves, pipes, filters, joints, etc. Water hammer does not have to occur fully to raise the pressure. A partial hammer can occur that raises the pressure to a certain percentage of the theoretical maximum. The SF Series Screen Filter is rated to an absolute maximum pressure of 150 PSI for bolted lid models, 125 PSI for band clamp lid models. A water hammer pressure spike that raises the pressure higher than the maximum rated pressure may result in filter damage.

WHAT CAN I DO TO PREVENT WATER HAMMER?

There are precautions that can be taken to prevent or decrease the effect of water hammer. A pressure relief valve that leads to a surge tank or accumulator may protect other key components from water hammer. A close adherence to operational policies will also help prevent valves or pumps from being accidentally shut off thereby causing a water hammer. A close examination of a system will alert you to the location of potential hazards.

VII. LIMITED WARRANTY

This Warranty gives you specific legal rights and you may also have other rights which vary from state to state.

- 1) **Duration:** Filter Housing: One year from the date of purchase by the original purchaser. Conical Screen: Ninety days from the date of purchase by the original purchaser (other than for purposes of resale).
- 2) **Who gives this warranty (Warrantor):** Thermal Care Incorporated / 7729 N. Lehigh Ave. Niles, IL 60714-3491 (847) 966-2260
- 3) **Who receives this warranty (Purchaser):** The original purchaser (other than for purposes of resale) of the Thermal Care product.
- 4) **What products are covered by this warranty:** Any SF Series Screen Filter housing and conical screen filter elements manufactured by the warrantor.
- 5) **What is covered under this warranty:** Defects on materials and workmanship, which occurs within the duration of the warranty period.
- 6) **What is not covered under this warranty:**
 - A) Implied warranties, including those of merchantability and fitness for a particular purpose, are limited to one year from the date of original purchase. Some states do not allow limitations on how long an implied warranty lasts, so the above limitations may not apply to you.
 - B) Any incidental, indirect, or consequential loss, damage, or expense that may result from any defect, failure, or malfunction of the Thermal Care product. Some states do not allow the exclusion or limitation of incidental or consequential damages, so the above limitation or exclusion may not apply to you.
 - C) Any failure that results from an accident, purchaser's abuse, neglect, or failure to operate the products in accordance with the instructions provided in the owner's manual supplied with the product.
 - D) Items or service that are normally required to maintain the product, i.e. gaskets, bolts, nuts, and washers.
- 7) **Responsibilities of warrantor under this warranty:** Repair or replace, at warrantor's option, products or components which have failed within the duration of the warranty period.
- 8) **Responsibilities of purchaser under this warranty:**
 - A) Deliver or ship the Thermal Care product to the Thermal Care manufacturing facility. Freight costs, if any, must be borne by the purchaser.
 - B) Use reasonable care in the operation and maintenance of the product as described in the owner's manual.
- 9) **When the warrantor will perform repair or replacement under warranty.**
 - A) Repair or replacement will be scheduled and serviced according to the normal workflow at the manufacturing facility, and depending on the availability of replacement parts.
 - B) If the purchaser does not receive satisfactory results from the product repair or replacement, the purchaser shall contact Thermal Care immediately.

NOTE: THIS WARRANTY IS VOID IN THE EVENT THE PURCHASER FAILS TO COMPLY WITH ANY ONE OF THE REQUIREMENTS FOR INSTALLATION AND USE OUTLINED OR SET FORTH IN THIS MANUAL AND THERMAL CARE INCORPORATED ASSUMES NO LIABILITY WHATSOEVER.



THERMAL CARE
7729 N. Lehigh Ave.
Niles, IL 60714-3491
Phone: (847) 966-2260
Fax: (847) 966-9358

The Thompson Filter is a product of Miller-Leaman, Inc. and is protected under patent #5,132,013



THERMAL CARE
7729 N. Lehigh Ave.
Niles, IL 60714-3491

Phone: (847) 966-2260
Fax: (847) 966-9358

OPERATION INSTRUCTIONS

FOR THE SF Series Screen Filter:

- I. AUTOMATIC TIMER FLUSH PACKAGE
- II. GENERAL INFORMATION

I. PRESSURE DIFFERENTIAL ALARM PACKAGE

Description:

The pressure differential alarm package continually monitors and displays the strainer's inlet and outlet differential pressure. When the strainer element (conical strainer basket) becomes significantly clogged, the pressure differential switch-gauge will trigger an audible siren and a visual flashing alarm light. These alarms are intended to alert maintenance personnel that the strainer element must be removed and cleaned (see your *SF Series Owner's Manual* for complete strainer element cleaning instructions).

PRESSURE DIFFERENTIAL ALARM PACKAGE

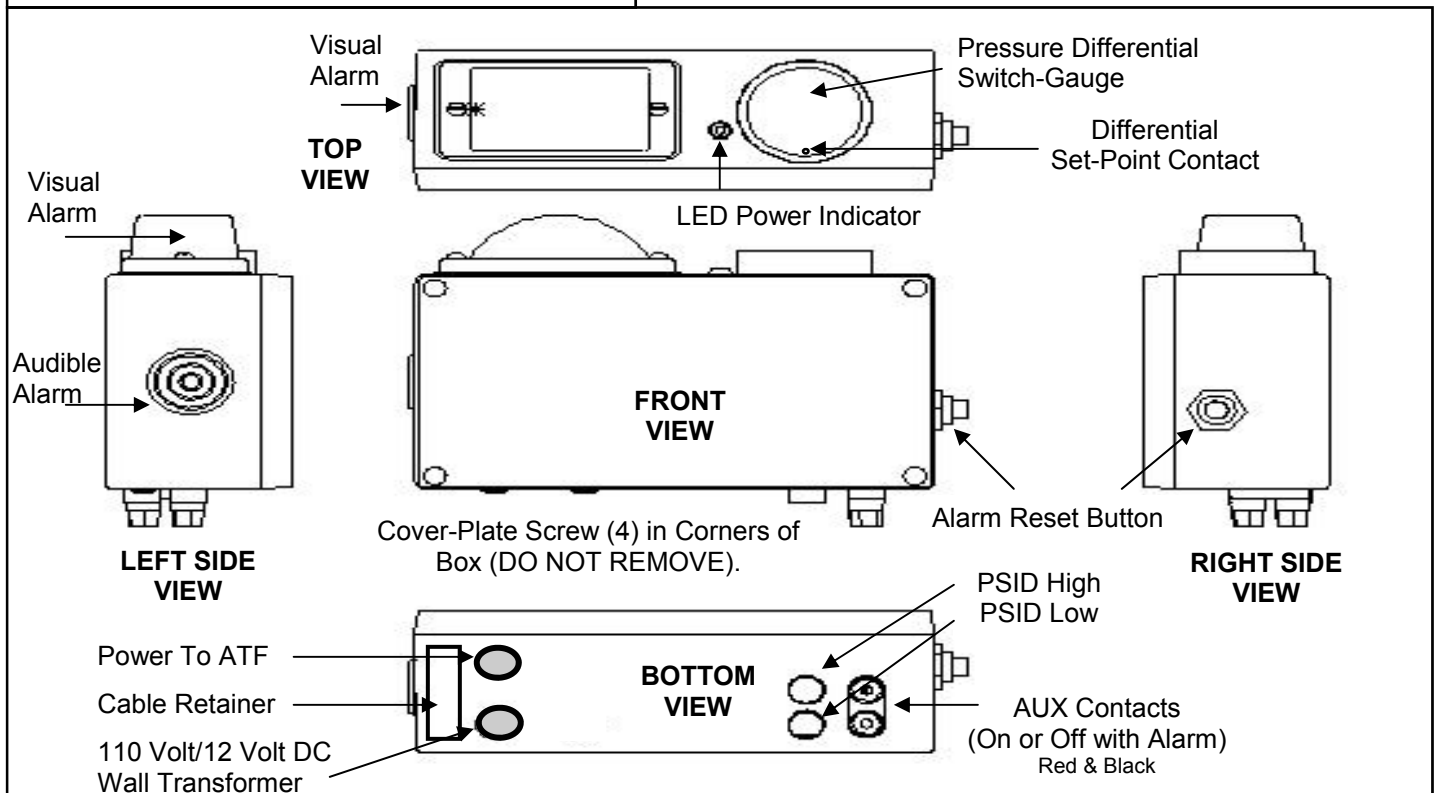

Operation Instructions:

Remove the power supply and insert the connector end into the socket on the bottom of the PDA housing, as indicated in the drawing above. Plug the transformer into the power source. Standard systems are supplied with a 120V power supply converted down to 12 VDC.

The pressure differential switch-gauge is factory set to 7-8 PSI. Since the *SF Series Screen Filters* operates with less than 1 PSI loss during maximum flow when the strainer screen is clean, the differential shown on the switch-gauge will be 1 PSI. Therefore, by the time the differential pressure rises to 7-8 PSI, the strainer element will have become significantly clogged and will require immediate removal and cleaning.

To adjust the pressure differential switch-gauge to a lower setting, simply insert a 1/16" allen wrench and rotate the differential set-point contact (see illustration above) to the desired location.

WE DO NOT RECOMMEND SETTING THE DIFFERENTIAL SWITCH-GAUGE HIGHER THAN 10 PSI. DISABLING THE ALARM OR INCREASING THE ALARM SET POINT COULD RESULT IN DAMAGE TO THE STRAINER ELEMENT AND ALLOW DEBRIS TO PASS INTO THE SYSTEM.

The alarms will engage when the differential set point is reached and will stay engaged until the Alarm-Reset button is pressed. (If the Alarm-Reset button is pressed but the strainer remains beyond the acceptable differential pressure, the alarms will re-engage immediately). The purpose of the alarm package is to alert maintenance personnel that the strainer element requires cleaning. Therefore, if the alarm has sounded, the strainer needs to be taken off-line and the strainer element needs to be cleaned as instructed in the *STRAINER ELEMENT CLEANING* section of the SF Series Screen Filter *Owner's Manual*.

After the strainer is cleaned and put back in service, the differential pressure should be back to 1 PSI. If the switch-gauge indicates a 1 PSI differential but the alarm is still sounding, press the Alarm-Reset button.

If you have any questions about the Pressure Differential Alarm Package, please call our product specialists at (847) 966-2260.

II. General Information

Auxiliary Contacts:

Black & Red Banana Clip Post, see illustration on front page. You have the option of 12 VDC or closed contacts when the alarm activates. See Auxiliary Contact Schematic inside PDA Box, remove the (4) screws on the cover plate and the schematic will be located inside the cover plate. If you have any additional questions please contact Thermal Care at (847) 966-2260.

Water Resistance:

The Pressure Differential Alarm Controller is water-resistant, but not water proof. Do not install below ground level where the box can be submerged in water. DO NOT REMOVE the cover plate from the PDA Controller. Keep the cover tightly sealed on the unit during normal operation.

Thermal Care Return Policy:

Units in need of warranty repair and less than 90-days old, must be returned to Thermal Care accompanied by a Return Material Authorization (RMA) number. To request a RMA number call (847) 966-2260.

Please Follow Environmental Note:

All PDA Controllers sent to Thermal Care for repair must be cleaned and dried from all foreign residue or the shipment will be returned "as is" to the customer. We cannot expose our technicians to the vast variety of chemicals used around our systems. Thank you for your cooperation.

Maintenance:

The Pressure Differential Alarm does not require regularly scheduled or annual maintenance. The PDA alarm should be checked twice a year by contacting the differential set-point (see illustration on first page) so that the audible and visual alarm engages and the alarm-reset button deactivates the alarms.



THERMAL CARE
7729 N. Lehigh Ave.
Niles, IL 60714-3491
Phone: (847) 966-2260
Fax: (847) 966-9358

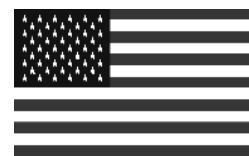

MADE IN THE USA

I. AUTOMATIC TIMER FLUSH PACKAGE

Description:

The **ATF-EA-1.5** valve package insures that the particulate that falls down to the debris reservoir is automatically flushed. The power supply and timer controls for the valve package are housed inside the ATF control box. Depending on the application, the end-user simply dials in the flush frequency and flush duration of the valve (instructions below). Based on the parameters that are programmed, the ball valve quickly opens and closes, minimizing the volume of water that is flushed from the strainer.

System Components: A. Timer Based Valve Controller (see illustration below) sets the flush duration (length of the flush) and the flush interval (time between flushes)
B. Electric Ball Valve: designed for dirty water use. (see illustration below and next page)

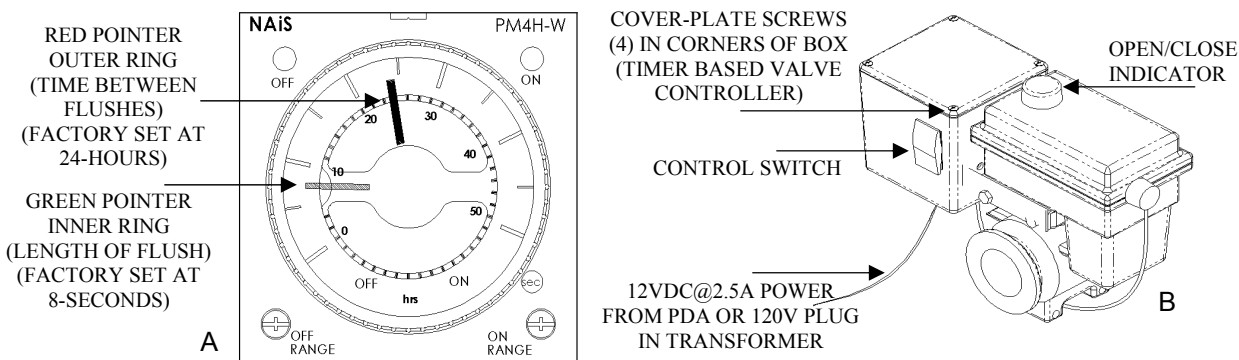

OPERATION INSTRUCTIONS:

FLUSH VALVE MUST BE PLUMBED TO ATMOSPHERE. THE FLUSH LINE SHOULD NOT HAVE ANY ELEVATION AND SHOULD NOT BE PIPED TO A PRESSURIZED LINE.

NOTE: THE AUTOMATIC TIMER FLUSH PACKAGE NEEDS TO BE PROGRAMMED WHEN IT IS RECEIVED BY THE END-USER. The programming is simple and takes only a few moments. However, because every application has different parameters that affect the required frequency between flushes and the duration of the flush, the end-user must choose the controller's settings (please reference your strainer manual).

To program the ATF Controller:

- Plug the transformer into a 120-VAC outlet.
- Insert the 12-VDC plug coming from the transformer into the jack on the underside of the ATF box.
- Test for power by pressing the manual flush side of the control switch (lower switch light should come on and the valve will start to open).
- Adjust the ON TIME (Valve Open) by turning the inner timer ring with the GREEN POINTER clockwise to increase duration. The **ON TIME RANGE** is factory set at fifty seconds. (see illustration above)
- Adjust the OFF TIME (Valve Close) by turning the outer ring with the RED POINTER clockwise to increase duration. The **OFF TIME RANGE** is factory set at fifty hours. (see illustration above)
- Set the control switch to auto flush. The red off light on the timer will come on and the upper light on the switch will come on and stay on. During the flush cycle the on light on the timer and the lower switch light will come on.

Control Switch: (see illustration above)

Control switch flushing is initiated by pressing and holding down the manual control switch located on the front of the controller. The manual flush control switch can also be used to conveniently drain the water out of the strainer before removing the conical screen element from the strainer housing. A yellow indicator arrow on top of the ATF Valve will rotate in sync with the ball valve to show the valve position (open or closed). When the manual flush control switch is released, the valve will automatically close.

SAFETY FIRST!

Keep fingers away from valve opening to avoid getting caught in the moving parts. The electric motor supplies a sufficient amount of power to cause personal injury. Take precaution when handling.

AUTOMATIC TIMER FLUSH ATF-EA-1.5

Valve Specifications

- A.** Water-resistant Polypropylene Motor Case
- B.** High Torque Motors with Permalube Gears
- C.** Open & Close Indicator
- D.** Stainless Steel Ball Valve & Hardware
- E.** Auto Reset Circuit Breaker
- F.** 90 Degree Bi-directional Rotation
- G.** Controller Case
- H.** Easy Programmable Timer

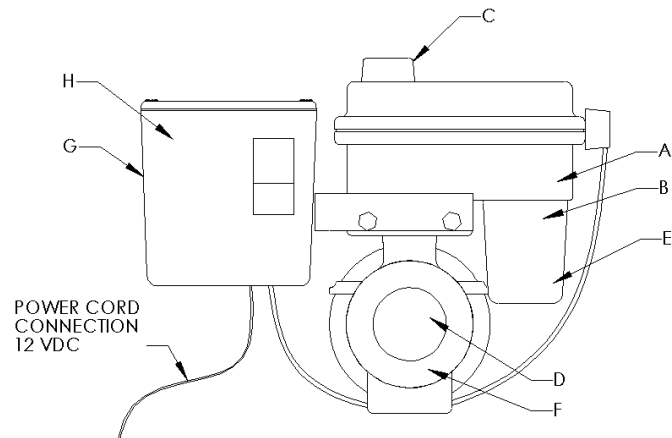

TROUBLESHOOTING: If you require further assistance, please call us at (847)966-2260.

<u>Problem</u>	<u>Possible Cause</u>	<u>Solution</u>
<ul style="list-style-type: none">• Valve is leaking past ball	<ul style="list-style-type: none">• Seals damaged or worn out• Valve is not stopping at proper closed position	<ul style="list-style-type: none">• Install repair kit• Adjust limit switches
<ul style="list-style-type: none">• Valve stem leaks	<ul style="list-style-type: none">• Worn stem seals	<ul style="list-style-type: none">• On metal valves: tighten stem packing nut 1/2 turn. CAUTION! Over tightening stem nut could cause drag on motor and trip internal circuit breaker. May require repair kit or new valve.
<ul style="list-style-type: none">• Valve body leaks	<ul style="list-style-type: none">• Loose body bolts or excessive operating pressure.• Defective seals	<ul style="list-style-type: none">• Check bolts and observe recommended pressure ratings• Install repair kits or new valve
<ul style="list-style-type: none">• Valve hard to turn	<ul style="list-style-type: none">• Swollen seals or product buildup in valve chamber• Valve bolts too tight• Stem nut too tight	<ul style="list-style-type: none">• Check valve for compatibility with product, may require valve cleaning or new valve• Loosen bolts slightly• Loosen stem nut slightly.

GENERAL INFORMATION

Water Resistance:

The Valve and Controller are water-resistant, but not water-proof. Do not install below ground level where the component can be submerged in water. Only remove the cover plate from the Valve Controller when setting or changing the flush settings. Keep the cover tightly sealed on the unit during normal operation.

Please Follow Environmental Note:

All ATF valves sent to Thermal Care for repair must be cleaned and the valve rinsed and dried from all foreign residue or the shipment will be returned "as is" to the customer. We cannot expose our technicians to the vast variety of chemicals used with the valve. Thank you for your cooperation.

Maintenance:

The ATF does not require regularly scheduled or annual maintenance. Valve leakage should be checked twice a year. If leakage is visible consult your troubleshooting chart for possible solutions.



7729 N. Lehigh Ave.
Niles, IL 60714-3491

Phone: (847) 966-2260
Fax: (847) 966-9358

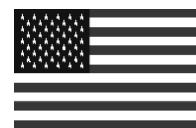

MADE IN THE USA