

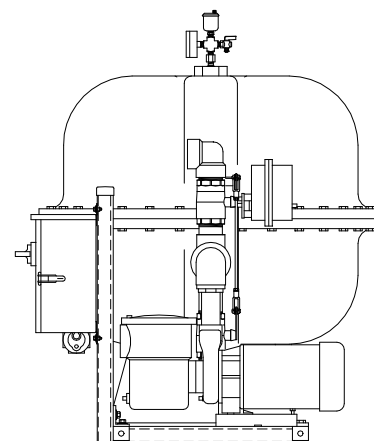

PS Series

Sand Media Filter

Design and Component Specifications

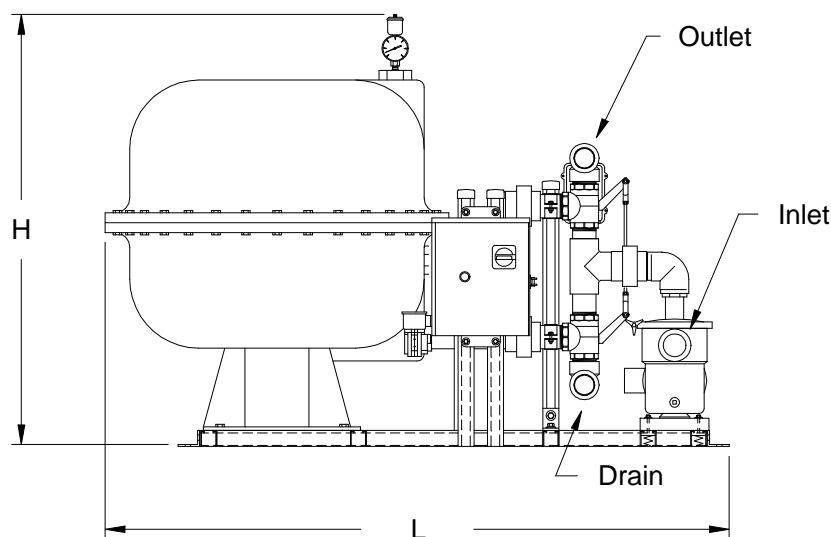
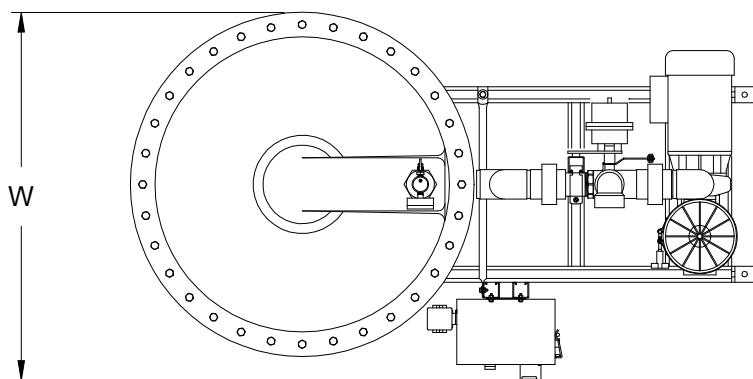

Model	Tower System Tons	Dimensions Inches			Connections Inches			Pump HP	FLA @ 460/3/60	Shipping Weight Lbs.	Operating Weight Lbs.
		L	W	H	Inlet	Outlet	Drain				
PS20F	20 - 400	66	30	54	2	2	2	1	2.4	350	445
PS24F	400 - 600	69	30	54	2	2	2	2	3.0	470	600
PS30F	600 - 1,000	72	35	54	2	2	2	3	4.5	740	995
PS36F	1,000 - 1,400	77	48	65	3	3	3	3	4.5	1,550	2,045
PS42F	1,400 - 1,900	77	48	65	3	3	3	5	7.5	2,265	2,970
PS48F	1,900 - 2,500	83	48	66	3	3	3	5	7.5	3,875	4,995



7720 North Lehigh Avenue
 Niles, Illinois 60714-3491
 Tel: (847) 966-2260
 Toll Free: (888) 828-7387
 Fax: (847) 966-9358

Email: info@thermalcare.com
 Website: www.thermalcare.com

Manufacturer reserves the right to change specifications or design without notice or obligation. Thermal Care is a registered trademark of MFRI, Inc.