



# FT Series

## Fiberglass Cooling Towers

---



---

Installation, Operation and Maintenance Manual

---

# Table of Contents

---

<b>FOREWORD</b> .....	<b>1</b>
<b>INSTALLATION</b> .....	<b>1</b>
Receiving Inspection .....	1
Fan Motor and Blade Assembly (FT8220-8250).....	1
Fan Motor, Fan Blade, and Sprinkler Head Assembly (FT8260-8270).....	1
Fan Motor, Fan Blade, and Sprinkler Head Assembly (FT8280).....	2
Inlet Louver Installation (FT8220).....	3
Inlet Louver Installation (FT8250).....	3
Inlet Louver Installation (FT8260-FT8280).....	3
Rigging, Handling, and Locating Equipment.....	3
Piping.....	4
Electrical Power.....	4
<b>START-UP PROCEDURE</b> .....	<b>4</b>
Pre-Start Cleaning.....	4
Trial Water Circulation.....	4
Trial Fan Operation.....	4
<b>OPERATION AND MAINTENANCE</b> .....	<b>5</b>
Fan Motor.....	5
Water Distribution.....	5
Seasonal Shutdown .....	5
Freeze Protection .....	5
<b>OPTIONS</b> .....	<b>5</b>
Float Valve.....	5
Fan Motor Thermostat.....	5
Basin Heater Package.....	6
Vibration Switch.....	6
Structural Steel Base & Legs .....	6
Equalization Connection.....	6
<b>CALCULATIONS</b> .....	<b>6</b>
Evaporation Loss .....	6
Drift Loss .....	6
Bleed-Off Rate.....	6
Number of Concentrations .....	6
Make-Up Water Required .....	6
<b>DRAWINGS &amp; CHARTS</b> .....	<b>7</b>
Figure 1 – Suggested Rigging Instructions .....	7
Figure 2 – FT8220 Cooling Tower Specification Drawing.....	8
Figure 3 – FT8250 Cooling Tower Specification Drawing.....	9
Figure 4 – FT8260, FT8270, and FT8280 Cooling Tower Specification Drawing.....	10
Figure 5 – FT8220 Structural Steel Base Option Drawing .....	11
Figure 6 – FT8250 Structural Steel Base Option Drawing .....	12
Figure 7 – FT8260, FT8270, and FT8280 Structural Steel Base Option Drawing .....	13
<b>WARRANTY INFORMATION</b> .....	<b>14</b>

## Foreword

---

The intent of this manual is to serve as a guide for placing your cooling tower in service and operating and maintaining it properly. Improper installation can lead to poor equipment performance or severe equipment damage. Failure to follow the installation instructions may result in damage that will not be covered by your warranty. It is extremely important that a qualified installation contractor perform all installation line sizing and piping. Please supply these instructions to your authorized refrigeration contractor.

This manual is supplemented as required to accommodate any special items that may have been provided for a specific application. The written information contained in this manual, as well as various drawings, are intended to be general in nature. The drawings included in this manual are typical only and may not represent the actual unit purchased. Drawings specifically applicable to each unit are included with the equipment and should be referred to for troubleshooting and servicing of the unit. Additional copies of drawings are available upon request. We strive to maintain an accurate record of all equipment during the course of its useful life. While every effort is made to standardize the design features of these chillers, the various options may make it necessary to rearrange some of the components; therefore, some of the general drawings in this manual may differ from your specific unit.

Specific references to current applicable codes, ordinances, and other local laws pertaining to the use and operation of this equipment are avoided due to their ever-changing nature. There is no substitute for common sense and good operating practices when placing any mechanical equipment into operation. We encourage all personnel to familiarize themselves with this manual's contents. Failure to do so may unnecessarily prolong equipment down time.

The cooling tower is designed for outdoor installation only. The use of untreated water in any cooling tower may cause serious health hazards, including the creation of conditions conducive to the development of Legionella bacteria, which is known to cause Legionnaire's disease. A water treatment program to stop biological contamination must be used for all cooling tower installations in order to reduce such hazards. Do not operate this equipment without a proper water treatment program. Failure to follow these instructions could result in a hazardous condition.

We recommend following good piping practices and the use of information in this manual. We cannot be held responsible for liabilities created by substandard piping methods and installation practices external to the chiller. We trust your equipment will have a long and useful life. If you should have any questions, please contact our

Customer Service Department specifying the serial number and model number of the unit as indicated on the nameplate.

## Installation

---

### Receiving Inspection

The cooling tower is skid mounted prior to shipment. Before accepting delivery, check the overall equipment condition for any visible damage. If damage is evident, it should be properly documented on the delivery receipt. Shipping damage is the responsibility of the carrier. In order to expedite payment for damages, it is important that proper procedures are followed and records kept. Photographs of damaged equipment are excellent documentation for your records.

Once the packing is removed, the unit should be inspected for hidden damage. Check for broken lines, damaged controls, or any other major component torn loose from its mounting point.

Any sign of damage should be recorded and a claim filed immediately with the shipping company. Our Customer Service Department will provide assistance in preparation and filing of your claims, including arranging for an estimate and quotation on repairs; however, filing the claim is the responsibility of the receiving party.

### Fan Motor and Blade Assembly (FT8220-8250)

In order to prevent possible shipping damage, the fan motor and fan blades ship uninstalled. The fan blade has been assembled and the fan pitch set at the factory. Use the following steps for installing the fan blade and motor:

1. Verify the fan pitch is set so the "0" on the fan blade lines up with the "0" on the fan hub.
2. Remove motor support frame from top of tower.
3. Set the motor frame up off the ground (use saw horses or some other means of support).
4. Place the motor with the shaft pointing down onto the motor frame and bolt the motor to the frame using the bolts provided.
5. Attach the fan blade to the motor shaft.
6. Remount the entire fan motor and fan assembly back on top of the cooling tower with the fan located down inside the tower.

### Fan Motor, Fan Blade, and Sprinkler Head Assembly (FT8260-8270)

In order to prevent possible shipping damage, the fan motor, fan blade, and sprinkler head assembly ship uninstalled. Use the following steps for installing the fan blade, fan motor, and sprinkler head assembly:

1. Remove motor support frame from top of tower.

2. Place a piece of plywood on top of the fill in the tower to prevent damage during installation.
3. Position sprinkler arms with studs in end of pipe positioned at 12 o'clock when viewed from outside of tower facing center.
4. With the sprinkler arm correctly positioned, tighten the retaining bolt on the sprinkler head until snug.  
**Note: Do not over tighten, as this will crack the sprinkler arm.**
5. Install "TEE" shaped tension wire support post on the top of the sprinkler head.
6. Loosen the turnbuckles to open them up all the way.
7. Hang the turnbuckle from the "TEE" shaped tension wire support post on top of the sprinkler head.
8. In the other end of the turnbuckle, tightly wrap one end of the wire; wrap the opposite end of the wire around stud and under flat washer. Tighten nut at the end of the sprinkler pipe.

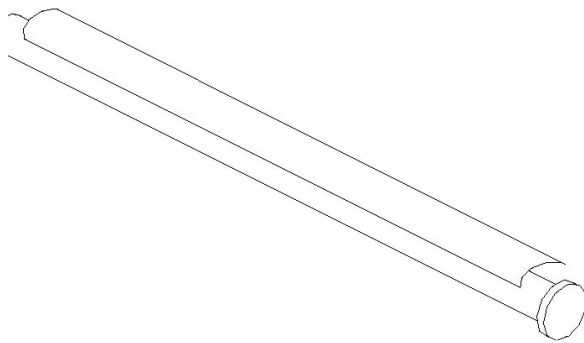
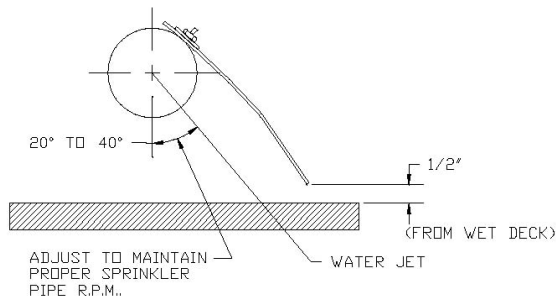

9. Tighten the turnbuckle until wire is tight and sprinkler pipe is level.
10. Place the fan motor on the ground with shaft up and fasten the motor frame with the provided 1/2" bolts.
11. Align key way and slide the fan hub onto the fan motor shaft with "U" bolts facing downward. Tighten fan hub onto motor shaft.
12. Install fan blades in their numerical order with corresponding number on fan hub making sure the "0" on the fan blade lines up with the "0" on the fan hub.
13. Make sure ALL blades are set to the same pitch.
14. Tightly secure the fan blades to the fan hub by progressively tightening the U-Bolt nuts. If the U-Bolt does not allow for a tight joint, replace and repeat the process until properly secured.

15. Recheck the pitch of each blade to ensure it did not change while tightening the nuts.
16. Remount the entire fan motor assembly on top of the tower with fan down inside the tower and bolt it back down.
17. Reinstall the fan guards.

### Fan Motor, Fan Blade, and Sprinkler Head Assembly (FT8280)

In order to prevent possible shipping damage, the fan motor, fan blade, and sprinkler head assembly ship uninstalled. Use the following steps for installing the fan blade, fan motor, and sprinkler head assembly:

1. Remove motor support frame from top of tower.
2. Place a piece of plywood on top of the fill in the tower to prevent damage during installation.
3. Position sprinkler arms with studs in end of pipe positioned at 12 o'clock when viewed from outside of tower facing center.
4. With the sprinkler arm correctly positioned, tighten the retaining bolt on the sprinkler head until snug.  
**Note: Do not over tighten, as this will crack the sprinkler arm.**
5. Install "TEE" shaped tension wire support post on the top of the sprinkler head.
6. Loosen the turnbuckles to open them up all the way.
7. Hang the turnbuckle from the "TEE" shaped tension wire support post on top of the sprinkler head.
8. In the other end of the turnbuckle, tightly wrap one end of the wire; wrap the opposite end of the wire around stud and under flat washer. Tighten nut at the end of the sprinkler pipe.

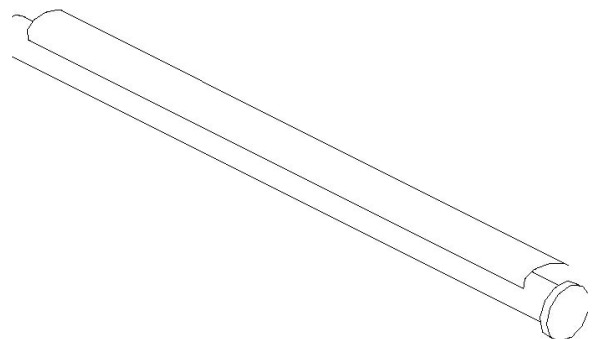
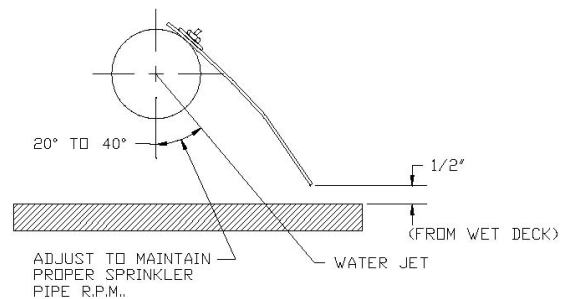

9. Tighten the turnbuckle until wire is tight and sprinkler pipe is level.
10. Set the motor frame up off the ground (use saw horses or some other means of support).
11. Place the motor with the shaft pointing down onto the motor frame and bolt the motor to the frame using the 1/2" bolts provided.
12. Grease the shaft with Anti-seize or some other type of grease. Slide the split tapered bushing onto the motor shaft with the shoulder of the bushing facing towards the motor. The bottom of the bushing should be flush with the end of the motor shaft.
13. Slide the tower fan (the top of the fan has the aluminum spool attached to it) over the split-tapered bushing.
14. Line up the non-threaded holes of the fan spool with the threaded holes in the split tapered bushing.
15. From the underside of the fan, insert the 1/4" x 4" bolts with lock washers provided through the non-threaded holes in the fan and screw them into the split-tapered bushing. The bushing should still be flush with the end of the motor shaft.
16. Tighten up the bolts in a uniform pattern until the fan locks onto the fan bushing. Once the bolts are tight, the fan bushing should still be flush with the end of the motor shaft.
17. Lift the entire fan motor and frame as one assembly, place it onto the top of the tower with the fan blade inside the tower and bolt it back down.
18. Reinstall the fan guards.

### **Inlet Louver Installation (FT8220)**

In order to prevent possible shipping damage, the inlet louvers ship uninstalled. Depending on the size of the cooling tower, you may have either PVC or galvanized steel casing supports. The casing supports are located between the basin and the main casing of the cooling tower. Align inlet louvers between the casing supports matching edge of inlet louver with holes in casing support. Only one hole is used to fasten louver. Mark and drill 5/16" holes in the inlet louvers and use provided nylon pushpins to secure the inlet louvers to the casing support. The pushpins should snap in place.

### **Inlet Louver Installation (FT8250)**

In order to prevent possible shipping damage, the inlet louvers ship uninstalled. Depending on the size of the cooling tower, you may have either PVC or galvanized steel casing supports. The casing supports are located between the basin and the main casing of the cooling tower.

1. Position the center of the louver over the casing support. Each end of the louver has a tab on the top of the louver that tucks under and behind the upper casing lip. Before drilling any holes and installing the mounting bolts, proceed to step two.

2. Position the second louver over the casing support in the same manner as in step one. At this point, the louvers will overlap one another. The tab on the louver should be tucked under and behind the upper casing lip the same as in step one for the first louver.
3. Install the remaining four louvers in the same manner until all louvers are in place.
4. All of the louvers should now be overlapping one another. Before drilling any holes, you may need to spread the louvers apart or overlap more to ensure proper fit.
5. Once the louvers are evenly spaced, drill a 5/16" hole all the way through the upper casing lip and louver tabs. Fasten the louver tab to the casing with a 1/4" bolt, two washers, one lock washer, and one nut, which are provided. One washer on the bolt head side and one washer and lock washer on the nut side. For more rigidity bolt the overlapping louvers together in the same fashion as above, but in a vertical pattern.

### **Inlet Louver Installation (FT8260-FT8280)**

In order to prevent possible shipping damage, the inlet louvers ship uninstalled. Depending on the size of the cooling tower, you may have either PVC or galvanized steel casing supports. The casing supports are located between the basin and the main casing of the cooling tower.

1. Position the center of the louver over the casing support as shown. Each end of the louver has a tab on the top of the louver that tucks under and behind the upper casing lip. Before drilling any holes and installing the mounting bolts, proceed to step two.
2. Position the second louver over the casing support in the same manner as in step one. At this point, the louvers will overlap one another. The tab on the louver should be tucked under and behind the upper casing lip the same as in step one for the first louver.
3. Install the remaining louvers in the same manner until all louvers are in place.
4. The louvers should now be overlapping one another. Before drilling any holes, you may need to spread the louvers apart or overlap them slightly to ensure a proper fit.
5. Once the louvers are evenly spaced, drill a hole all the way through the upper casing lip and louver tabs. Fasten the louvers with the bolts provided. For more rigidity, bolt the louvers together at the bottom, but not to the basin lip.

### **Rigging, Handling, and Locating Equipment**

Proper rigging methods must be followed to prevent damage to components. Avoid impact loading caused by sudden jerking when lifting or lowering the chiller. Use pads where abrasive surface contact is anticipated. It is highly recommended that spreader bars be used. Keep

rigging clear of inlet piping. Do not use the motor support for lifting the cooling tower.

The location of the cooling tower must be outdoors and depends on such considerations as space, proximity to walls and other equipment, accessibility, and serviceability. Above all, it is important that air intake is not hindered or affected by heat and/or humidity producing devices. The discharge air must be allowed to flow upwards without obstruction.

The cooling tower uses support piers or support frames for support. Prefabricated steel support frames are an available option. Please refer to the drawings at the back of this manual for support frame details.

### Piping

The tower is equipped with PVC piping and the connections are not designed to support the weight of the external piping. Inspect water spray nozzles when installing connecting piping to the tower inlet lines. This inspection should be done through the access door on the side and through the top of the cooling tower. All spray nozzles must be oriented in a fully vertical position to ensure proper water distribution through the tower. These should be adjusted before final connections are made to the tower. The cooling tower is supplied with PVC pipe stub connections. Optional inlet and outlet flanges are available. Inlet butterfly valves are recommended. Where climates reach freezing temperatures, be sure the supply line to the tower is able to drain when the pump shuts off.

### Electrical Power

All wiring must comply with local codes and the National Electric Code. Minimum Circuit Ampacities (MCA) and other unit electrical data are on the unit nameplate. The cooling tower was designed and sold to operate with a specific voltage and frequency and can operate with voltages  $\pm 10\%$  of that design with a supply frequency of  $\pm 5\%$  and with a maximum voltage imbalance between the legs of 2%. Using a supply voltage/frequency at or beyond these range limits will cause a unit fault.

Voltage imbalance is determined using the following calculations:

$$\% \text{Imbalance} = (V_a - V_x) \times 100 / V_a$$

$$V_a = (V_1 + V_2 + V_3) / 3$$

$V_x$  = phase with greatest difference from  $V_a$

For example, if the three measured voltages are 442, 460, and 454 volts, the average would be:

$$(442 + 460 + 454) / 3 = 452$$

The percentage of imbalance is then:

$$(452 - 442) \times 100 / 452 = 2.2 \%$$

This exceeds the maximum allowable of 2%.

If the measured voltage on any leg is not within the specified range, notify the supplier and correct before operating the unit.

## Start-Up Procedure

---

### Pre-Start Cleaning

Once the tower has been completely assembled and placed, make sure all disconnects are locked out. Remove one of the inlet louver sections. Open the drain and flush the basin with water to remove any remaining dirt and debris from basin. Check all fasteners to make sure there are no loose components.

**Note: A wood support is under the standpipe collar in order to prevent shipping damage and movement of the fill supports during shipment. Remove this wood support prior to operation.**

### Trial Water Circulation

Fill the circulation system with water. If the basin of the cooling tower is fitted with a make-up, fill the system until the make-up valve is closed. Check tower basin and connections for leaks. Close discharge valves of pumps completely. Check rotation of tower pumps by starting them momentarily. Once proper pump rotation is established, slowly open each pump discharge valve to 1/4 open and run the pumps for about five minutes to make sure all air has been removed from the system. Stop pumps and check tower outlet to make sure it is still clean and free from debris. Check water level in the system again to make sure system is still full. Start pumps again. While pumps are running, set the flow to the tower by adjusting the discharge valves of the pumps. After steady water flow is established, adjust tower inlet valves so the sprinkler head is rotation at 5 to 8 RPM. This typically requires about 5 psi of inlet pressure to the tower. Stop the pumps and lock out disconnects until ready to start system.

### Trial Fan Operation

Lock out all disconnects before servicing any portion of the tower. Check for smooth operation and clearance between blades and tower by manually turning the fan blade. Clear the air intake and discharge areas of any foreign material. Check the power supply for correct voltage, frequency, and phase. Turn on fan motor for a moment to check fan rotation to confirm fan will properly discharge air out of top of tower. If the fan is rotating in the wrong direction, turn off fan motor, wait for fan to stop, and lock out disconnect. Rewire fan

motor, by switching any two power leads. Once proper rotation has been established, operate the fan motor and check the amp draw to verify that it falls within the nameplate rating. If amp draw is in excess of the nameplate amps, call the Customer Service Department for assistance. Continue to operate the fan motor for two or three hours. If abnormal vibration or sound develops, disconnect power and contact the Customer Service Department for assistance. Stop fan motor and lock out disconnects until ready to start the system. Check all fan bolts to assure they are tight.

## Operation and Maintenance

---

### Fan Motor

The motor should bring the fan up to full speed in less than five seconds. If it does not, check connections, fuses, overloads, and voltage at the motor terminals. If everything does not properly check out, call the Customer Service Department for assistance.



**CAUTION:** Do not cycle a motor on and off more than necessary. Frequent cycling may cause the windings to burn out. Generally, the total of the starting times should not exceed 12 starts per hour. When changing fan direction, allow a minimum of two minutes before reenergizing the motor.

### In Case of Vibration

If vibration occurs, the fan must be shut off immediately. Check the motor mounting and make sure all fasteners are tight. If everything is tight remove fan blade assembly from motor and start without the fan blade. If the motor vibrates, contact the Customer Service Department for instructions. If the vibration is not in the motor, check the alignment of motor with mechanical equipment and the balance of the fan blade. Make sure all fan blades are secure and complete. If source of vibration cannot be isolated, contact the Care Customer Service Department for assistance. A vibration switch can be installed to protect the tower from potential damage caused by vibration.

### Water Distribution

Under normal operating conditions the sprinkler head is designed to rotate between 5 and 8 RPM. Scale or sludge buildup will impede the proper operation of the sprinkler head assembly. If the sprinkler head rotation drops below 5 RPM or stops entirely, check the inlet water pressure to make sure it is correct. If it is not correct, dismantle and clean the sprinkler head and pipes with a plastic bottlebrush and cleaning solution. Do not soak nozzle in cleaning solution. Only use a cleaning solution with a pH of 3.0 or greater. Refer to the Installation section of this manual for instructions on sprinkler head installation.

### Seasonal Shutdown

If the tower will be shutdown during the winter, it is recommended that the motor be run for three hours a month to keep the bearings lubricated and the windings dry. Be sure to inspect motor before bringing it back into full operation. Check basin for debris, clean if required. Inspect fill for contamination, change fill if needed.

### Freeze Protection

When cooling towers are subjected to intermittent shutdown (nights, weekends, etc.) during cold weather, or when operating against minimum loads, the opportunity for freezing of the water contained in the water basin and internal piping within the tower exists. Maintain freedom of fan rotation. Do not operate if snow, ice, or other obstructions will interfere with fan rotation.

An indoor auxiliary sump is the best means of avoiding tower freeze-up. With a properly piped remote sump system the water within the tower basin and internal piping of the tower is allowed to drain to the indoor sump whenever the recirculation water pump is stopped.

Where a remote sump is impractical because of tower location or space limitation, heat must be supplied to the water in the tower basin through the use of electric immersion heaters. Basin heater packages are available.

## Options

---

### Float Valve

This option includes float valve bulkhead fitting, plugged drain connection, and overflow fitting. The float valve threads into the bulkhead fitting in the basin of the cooling tower. The bulkhead fitting is not installed unless the float valve option is ordered. To install, hand tighten the valve with the discharge pointing down. Establish basin water level by loosening wing nut at the pivot point, adjust float arm and retighten until the water level rises 2 inches below the overflow.

**Note:** If water supply pressure is above 50 PSI, the float may not be able to shut off the make-up valve. This requires installation of a pressure reducing valve in the water supply line.

### Fan Motor Thermostat

This option includes a ship loose thermostat to be mounted in the field piping for the purpose of cycling the cooling tower fan and/or pump to maintain the cooling tower return water temperature during changing load or ambient temperature conditions. See the suggested electrical wiring diagram at the back of this manual for reference.

## Basin Heater Package

For applications in climates subjected to occasional freezing temperatures, basin heaters can prevent water in the tower basin from freezing. The basin heater package includes two heaters, thermostat and low level cutoff switch. See the suggested electrical wiring diagram at the back of this manual for reference.

*Note: Electric basin heaters WILL NOT protect exposed supply and return water piping. Such piping, as well as the exposed make-up water line, must be separately heat traced and insulated. It is not normally necessary to protect horizontal piping at the top of the tower since it is usually self-draining into the tower. Risers above the level of the cold water basin can be protected by simply installing a small bypass line from the riser to the cold water basin to permit back draining.*

## Vibration Switch

This option includes a ship loose vibration switch which is designed to protect the tower by shutting off the fan if excessive vibration develops.

## Structural Steel Base & Legs

The structural steel base is designed to elevate the tower with four steel legs. The legs weld directly to the steel base and include cross bracing as required for structural stability. Tower legs are available up to 20 feet in length. Refer to the drawings at the back of this manual for specifications and dimensions of base and legs.

## Equalization Connection

When more than one tower is used on an installation, without a remote sump, the overflow point of all towers should be at the same level to prevent a tower from flooding. In addition, an equalization connection connects the basins together to assure a consistent operating level.

## Calculations

---

### Evaporation Loss

If exact evaporation losses are not known, an approximation can be obtained by using the following formula (see ASHRAE Equipment 1992, 39.11):

$$\text{Evaporative Loss (GPM)} = \text{Range} \times \text{GPM} \times .0008$$

*Range = water in (°F) less water out (°F)*  
*GPM = gallons of water per minute through the tower*

### Drift Loss

Drift loss can be approximated from the equation below which assumes a loss of .02% of the water flowing through the tower.

$$\text{Drift Loss (GPM)} = \text{GPM} \times .0002$$

## Bleed-Off Rate

The bleed-off rate required is dependent on the condition of the makeup water and the number of concentrations desired. The bleed-off rate should therefore be calculated by the company providing the water treatment equipment.

## Number of Concentrations

The number of concentrations present in the system is the measure of how concentrated the level of dissolved solids in the water.

$$\text{Number of Concentrations} = \frac{\text{Evaporation} + \text{Drift} + \text{Bleed-Off}}{\text{Drift} + \text{Bleed-Off}}$$

## Make-Up Water Required

The amount of make-up water required is dependent on a number of factors

$$\text{Make-up water required (GPM)} = E + D + B$$

*E = Evaporative Loss in Gallons per Minute*

*D = Drift Loss in Gallons per Minute*

*B = Bleed-Off Rate in Gallons per Minute*

# Drawings & Charts

Figure 1 – Suggested Rigging Instructions

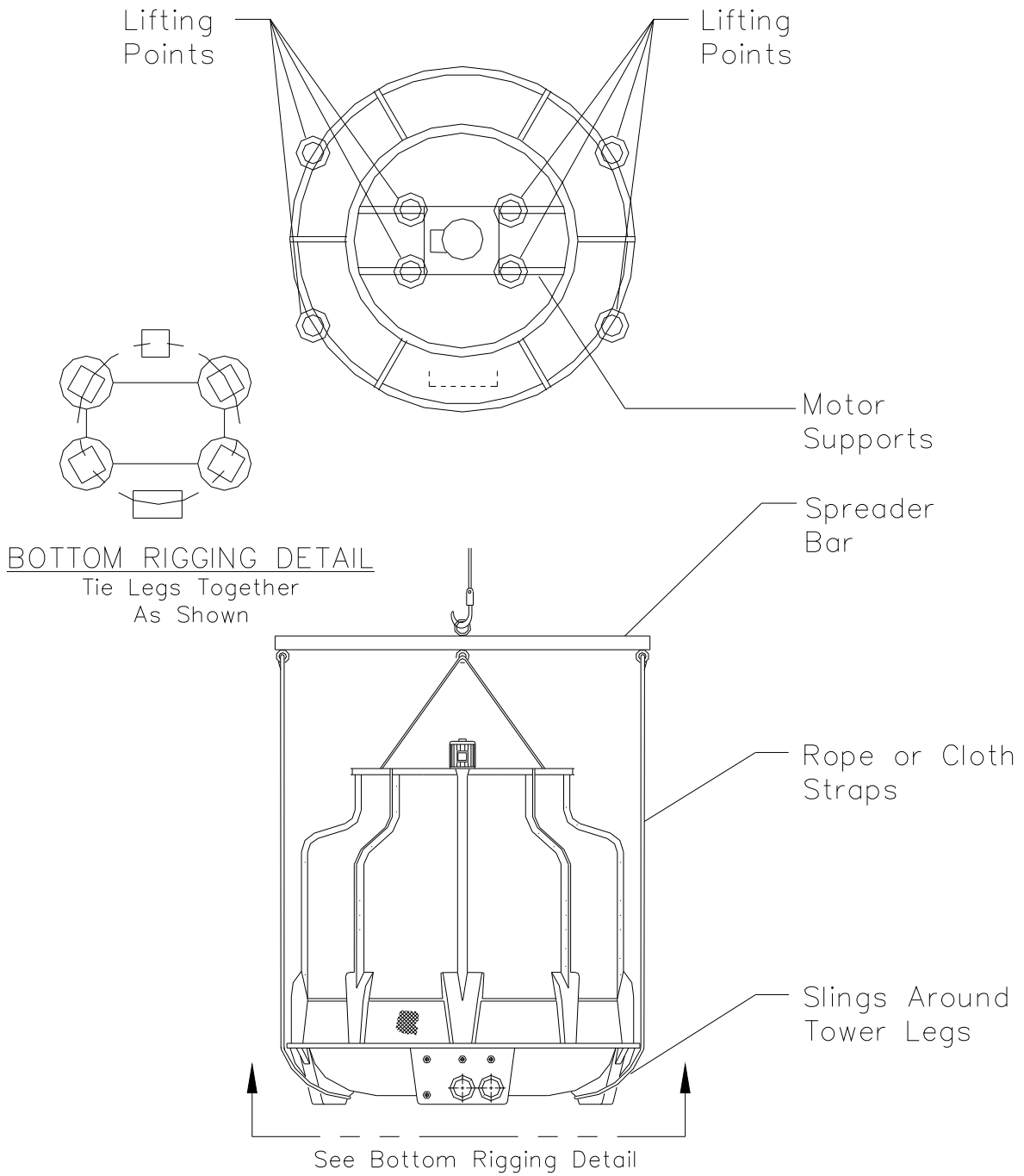
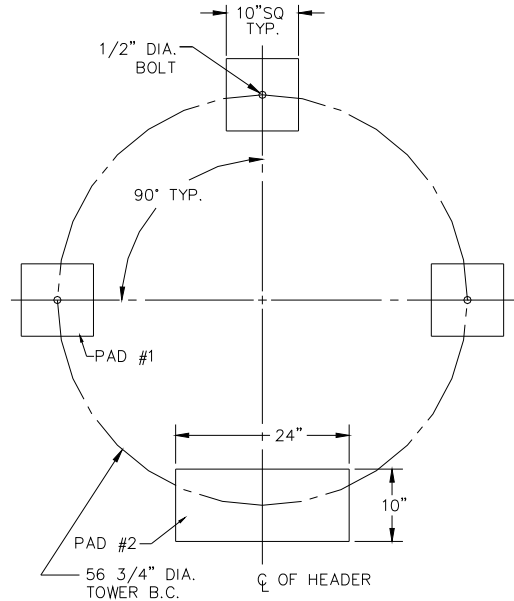
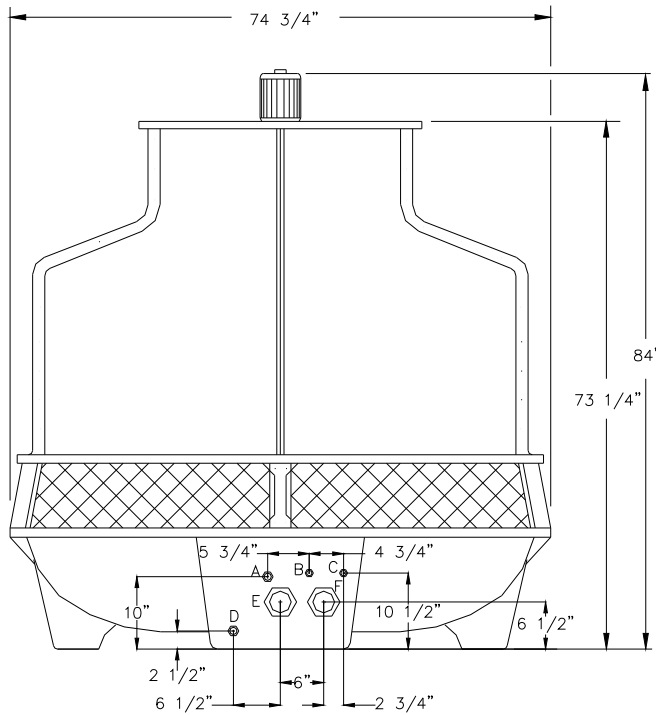

Figure 2 – FT8220 Cooling Tower Specification Drawing

## SPECIFICATION FOR MODEL FT8220

MODEL NO.	FAN HP	FAN MOTOR FLA (208–230/460V)	MINIMUM FLOW (GPM)	MAXIMUM FLOW (GPM)	PUMP HEAD (FT)	SHIPPING WEIGHT (LBS)	OPERATING WEIGHT (LBS)	PAD LOADING WITH 125 MPH WIND LOAD (LBS)		
								PAD #1	PAD #2	PAD #3
FT8220	2	7.2–6.4/3.2	60	200	7.0	600	1475	780	470	N/A



GENERAL PAD LAYOUT

NPT PIPE CONNECTION (INCH)					
A	B	C	D	E	F
OVER FLOW	QUICK FILLER	MAKEUP	DRAIN	INLET	OUTLET
1	3/4	3/4	2	3	3

(NOTE: MINIMUM 1/2 TOWER DIAMETER CLEARANCE REQUIRED)  
 SPECIFICATIONS SUBJECT TO CHANGE  
 CONSULT FACTORY FOR LATEST DATA  
 NOT TO SCALE

Figure 3 – FT8250 Cooling Tower Specification Drawing

SPECIFICATION FOR MODEL FT8250

MODEL NO.	FAN HP	FAN MOTOR FLA (208-230/460)	MINIMUM FLOW (GPM)	MAXIMUM FLOW (GPM)	PUMP HEAD (FT)	SHIPPING WEIGHT (LBS)	OPERATING WEIGHT (LBS)	PAD LOADING WITH 125 MPH WIND LOAD (LBS)		
								PAD #1	PAD #2	PAD #3
FT8250	2	9.4-8.5/4.3	90	340	9.8	750	2100	590	355	460

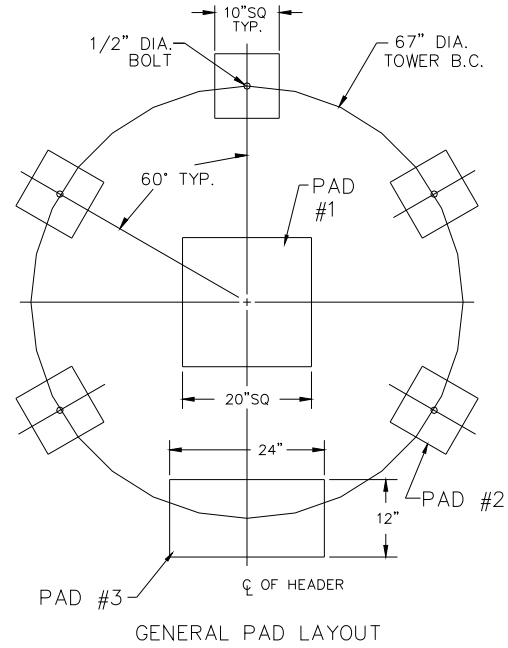
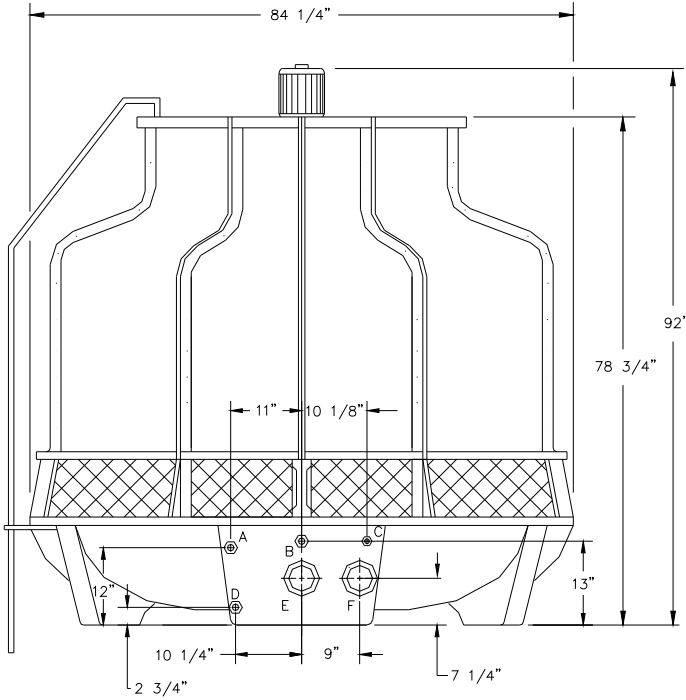

NPT PIPE CONNECTION (INCH)				FLANGED	
A	B	C	D	E	F
OVER FLOW 1	QUICK FILLER 1	MAKEUP 3/4	DRAIN 2	INLET 4	OUTLET 4

(NOTE: MINIMUM 1/2 TOWER DIAMETER CLEARANCE REQUIRED)  
 SPECIFICATIONS SUBJECT TO CHANGE  
 CONSULT FACTORY FOR LATEST DATA  
 NOT TO SCALE

Figure 4 – FT8260, FT8270, and FT8280 Cooling Tower Specification Drawing

SPECIFICATION FOR MODELS FT8260, FT8270 & FT8280

PART NUMBER	MODEL NO.	FAN HP	FAN MOTOR FLA (208-230/460)	MINIMUM FLOW (GPM)	MAXIMUM FLOW (GPM)	PUMP HEAD (FT)	SHIPPING WEIGHT (LBS)	OPERATING WEIGHT (LBS)	PAD LOADING WITH 125 MPH WIND LOAD (LBS)			DIM. "H"
									PAD #1	PAD #2	PAD #3	
9602710	FT8260	3	11.5-10.3/5.2	180	500	9.8	1250	2780	660	490	580	109"
9602711	FT8270	3	11.5-10.3/5.2	180	500	10.5	1300	2890	695	510	605	109"
9603641	FT8280	5	16.4-15.4/7.7	180	500	11.7	1400	3050	710	540	630	115"

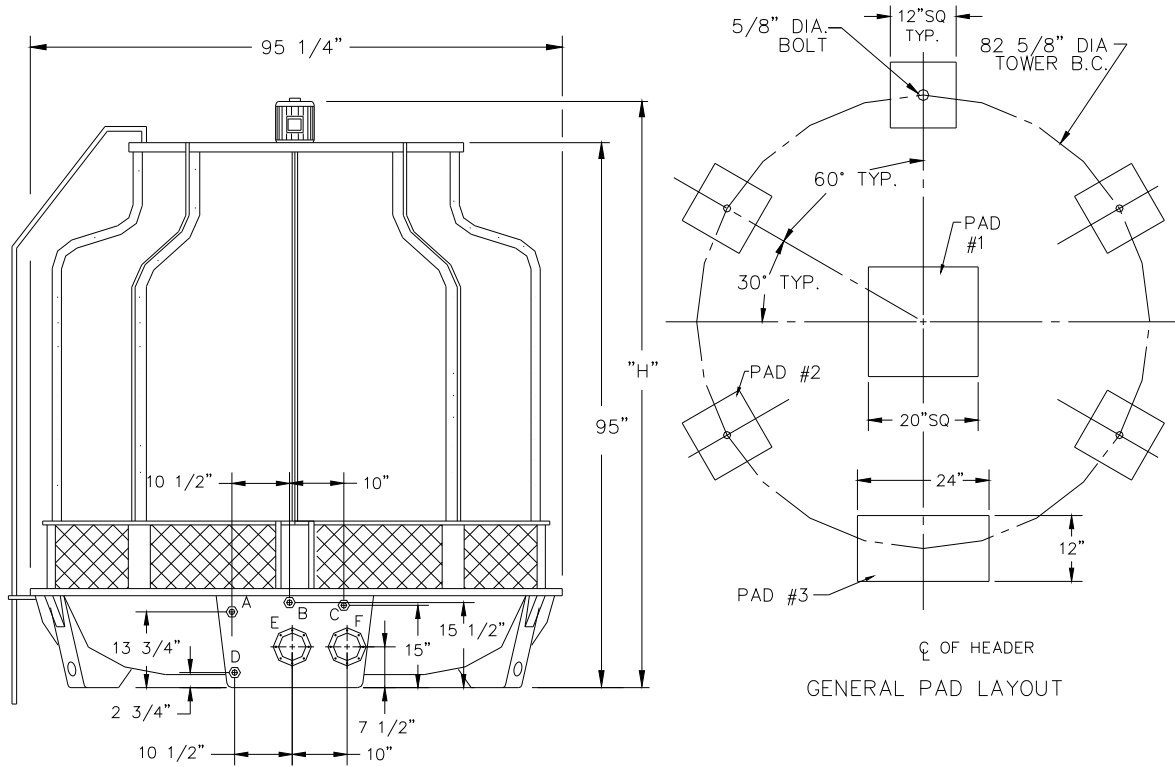

NPT PIPE CONNECTION (INCH)				FLANGED	
A	B	C	D	E	F
OVER FLOW	QUICK FILLER	MAKEUP	DRAIN	INLET	OUTLET
1	1	1	2	5	5

(NOTE: MINIMUM 1/2 TOWER DIAMETER CLEARANCE REQUIRED)  
 SPECIFICATIONS SUBJECT TO CHANGE  
 CONSULT FACTORY FOR LATEST DATA  
 NOT TO SCALE



Figure 6 – FT8250 Structural Steel Base Option Drawing

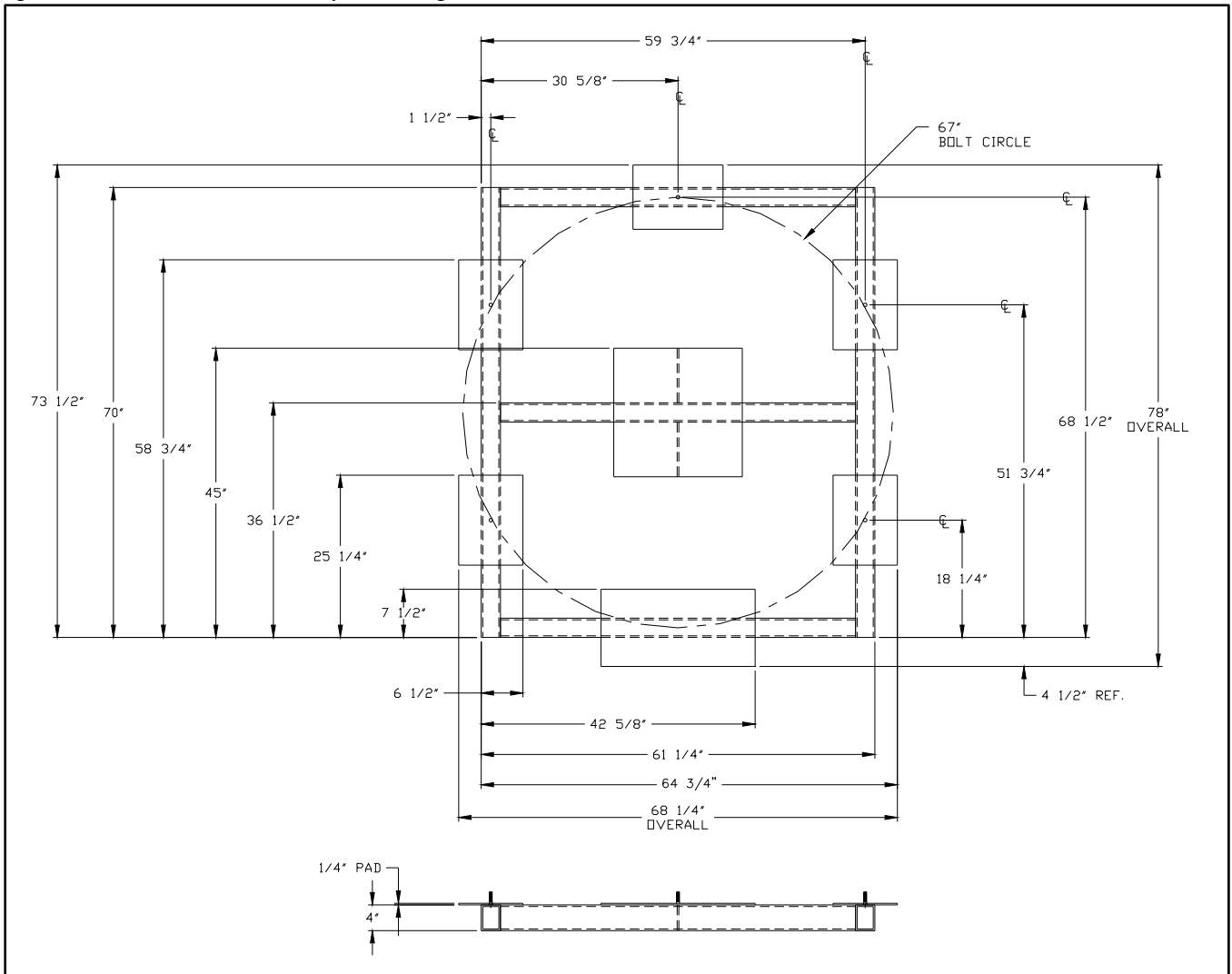

Figure 7 – FT8260, FT8270, and FT8280 Structural Steel Base Option Drawing

