



# C903

## Frozen Beverage Freezer

Two Flavor

### Features

Vary your menu by offering frozen smoothies, fruit drinks, cocktails, coffees, cappuccino and tea slush beverages, all served at the desired thickness.

### Totally Automatic

Fully integrated system serves high profit frozen beverages with minimal labor requirements. Just replace the bag-in-box syrup container when empty.

### Programmable Control

Microprocessor touch controls are embedded in durable tempered glass panel. Controls are password protected to minimize tampering in self-service applications. Automatic defrost cycles can be programmed during slow periods. Specially designed consistency control maintains superior product quality.

### Food Safety

Owner/operator defines cleaning frequency dependent on the product used (always follow your local health codes). Control notifies the operator when cleaning is required, and automatically lowers the product level to reduce waste. Water connection aids in rinsing and sanitizing operations. Equipment locks out if cleaning is not performed to assure food safety.

### Visual Self-Merchandiser

Lighted, colorful graphics on front and both sides, with backlit flavor cards (sold separately), and illuminated product in two, 10 quart (9.5 liter) removable clear bowls draw customer attention. Frozen product continuously moves in the unique bullet shaped bowl to self-merchandise the product.

### Automatic Fill

Peristaltic pumps automatically keep the bowls full for maximum capacity. With the water supply connected to the rear, set the control for the proper syrup to water ratio: from 4:1 to Ready to Use (RTU) or pre-mixed products.

### Refrigerated Mix Cabinet

Lower refrigerated cabinet holds two, 3 gallon (11.4 liter) bag-in-box syrups or mix tanks for any pre-mixed recipe. Refrigerated to maintain mix below 41°F (5°C). Prechilled mix improves capacity.

### Smart Technology

Tracks maintenance and cleaning compliance. Electronically monitors and reports product usage by bowl and daypart.



C903



Standard 6 & 18



SA2650



Selected 50 Hz. Models

Rockton, Illinois 61072  
800-255-0626  
Phone 815-624-8333 Fax 815-624-8000  
[www.taylor-company.com](http://www.taylor-company.com)  
e-mail: [info@taylor-company.com](mailto:info@taylor-company.com)

International Office  
Taylor Company S.r.l.  
Roma, Italy  
Tel: +39-06-420-12002 Fax: +39-06-420-12034  
e-mail: [romeoff@taylor-company.com](mailto:romeoff@taylor-company.com)

Packaging - Processing  
**Bid on Equipment**  
1-847-683-7720  
[www.bid-on-equipment.com](http://www.bid-on-equipment.com)

# C903 Frozen Beverage Freezer

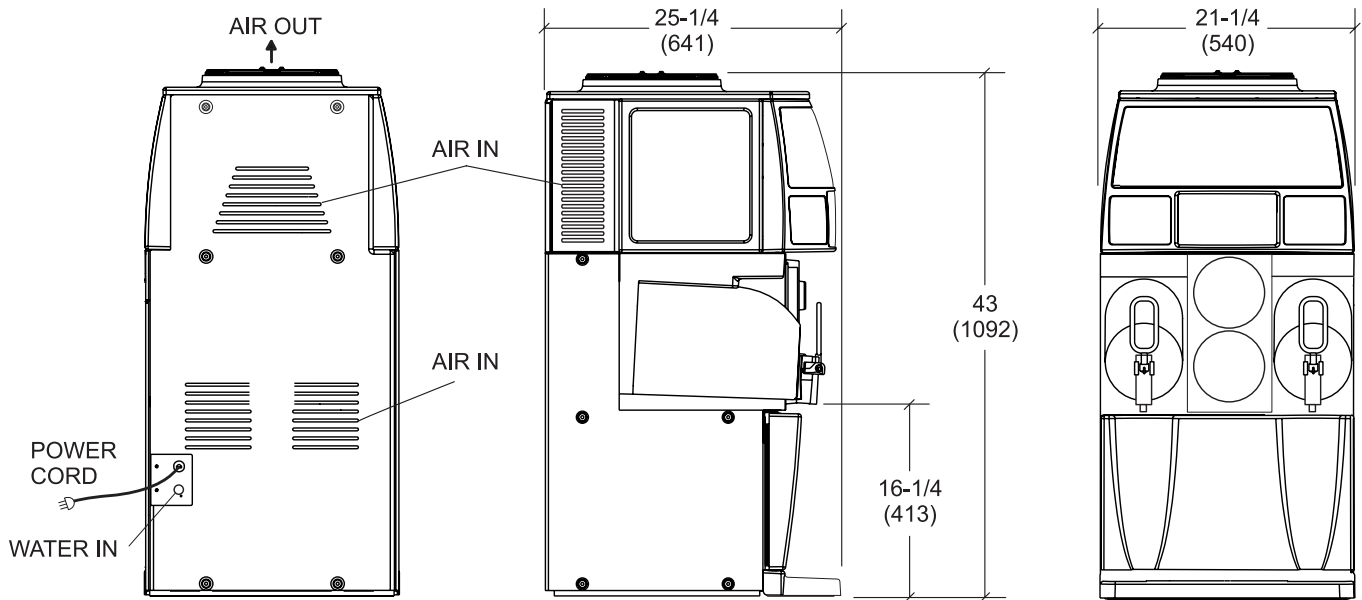

NOTE: FIGURES IN PARENTHESES INDICATE MILLIMETERS.

Weights	lbs.	kgs.
Net	245	111.1
Crated	300	136.1
	cu. ft.	cu. m.
Volume	29.4	0.83

Dimensions	in.	mm.
Width	21-1/4	540
Depth	25-1/4	641
Height	43	1092
Counter Clearance	----	----

Designed to rest on a plastic pad directly on counter top.

Electrical	Total Amps	Supplied with NEMA Cord
115/60/1 Air	12.0	5-15P
220-240/50/1 Air	4.0	----

This unit may be manufactured in other electrical characteristics. Refer to the local Taylor Distributor for availability.  
(For exact electrical information, always refer to the data label of the unit.)

## Bidding Specs

Electrical: Volt \_\_\_\_\_ Hz \_\_\_\_\_ ph \_\_\_\_\_  
Neutral:  Yes  No Cooling:  Air  Water  NA

Options: \_\_\_\_\_

## Specifications

### Electrical

One dedicated electrical connection is required. See the Electrical chart for the proper electrical requirements. Manufactured to be cord connected.

### Potable Water

One, 1/4 MFL connection at rear of unit for rinsing and automatic brining capabilities. Minimum 25 PSI for proper operation.

### Refrigeration System

One, approximately 4,000 BTU/hr compressor. R404A. (BTUs may vary depending on compressor used.)

### Beater Motor

Two, 1/8 HP, magnetic drive.

### Air Cooled

Minimum Clearance: 3" (76 mm) at rear and 12" (305 mm) on top. (No clearance required on either side.) Minimum air clearances must be met to assure adequate air flow for optimum performance.

### Refrigerated Cabinet

Interior dimensions of cabinet are:  
Width: 17" (432 mm)  
Depth: 12-3/8" (314 mm)  
Height: 11-1/4" (286 mm)

## Options

- Merchandising Graphic Translites
- Radio Frequency Identification (RFID) capability (Contact your mix supplier for availability in your area)

Continuing research results in steady improvements; therefore, these specifications are subject to change without notice.



**Taylor Company,**  
A Division of Carrier Commercial Refrigeration, Inc.  
Rockton, Illinois 61072  
815-624-8333 800-255-0626 Fax 815-624-8000  
www.taylor-company.com

**Packaging - Processing**  
**Bid on Equipment**  
1-847-683-7720  
www.bid-on-equipment.com