



TOTALLY DIFFERENT.



C606

Heat Treatment Combination Shake and Soft Serve Freezer

Features

The Heat Treatment system provides a daily heating and cooling cycle to safely maintain dairy products up to two weeks before a complete disassembly and cleaning is required. Heat Treatment freezers address food safety, product waste, maintenance and repair cost concerns.

Shake Dispensing

Offer four separate shake flavors: chocolate, vanilla, strawberry and an optional flavor. Place the cup on the cup holder below the door spout and press the proper flavor button. Frozen shake mix and syrup are automatically blended and dispensed into the cup. When the cup is properly filled, the portion control shuts the syrup off just before the dispensing door closes to assure no carry over of flavor or color.

Shake Syrup System

Syrup delivery system allows syrups to be dispensed from the original packaging, located in the lower front compartment. Syrups may contain small, soft particulates, such as pulp and seeds, to serve premium quality shakes. Peristaltic pumps deliver the proper amount of syrup for the best flavor and consistency. For each new syrup container, the microprocessor control calibrates the proper syrup flow accurately the first time, without additional adjustments.

Soft Serve Dispensing

Ergonomic draw handle with hidden adjustment screw allows the operator to set the proper draw rate. Star design pattern is integrated into the dispensing door, reducing operator replacement parts.

Programmable Control

Microprocessor touch controls are embedded in durable tempered glass panel. Multiple languages are selectable: English, Danish, French, German, Japanese, Spanish, and Swedish. Viscosity is continually measured to serve consistent quality shake and soft serve. LED displays the number of days to brush cleaning. Temperatures in the hoppers or freezing cylinders may be displayed at any point of operation. History of temperatures and times during the last 366 heat cycles may be viewed from the fluorescent display.

Syrup Rail

Four compartment syrup rail for sundae toppings; two heated with syrup pumps and two room temperature with lids and ladles.

Indicator Lights and Audible Alarms

Mix Low light and operator enabled audible alarm alert the operator to add mix. When the Mix Out light flashes, the unit automatically goes into Standby mode to prevent damage.

Freezing Cylinder

Shake side, 7 quart (6.6 liter). Soft Serve side, 3.4 quart (3.2 liter).

Mix Hopper

Two, 20 quart (18.9 liter). Refrigerated to maintain mix below 41°F (5°C). Air/mix pumps deliver the precise amount of air and mix to the freezing cylinder.



Standard 6



SA2650



Selected 50 Hz. Models

Rockton, Illinois 61072
800-255-0626
Phone 815-624-8333 Fax 815-624-8000
www.taylor-company.com
e-mail: info@taylor-company.com

International Office
Taylor Company S.r.l.
Roma, Italy
Tel: +39-06-420-12002 Fax: +39-06-420-12034
e-mail: romeoff@taylor-company.com

Packaging - Processing
Bid on Equipment
1-847-683-7720
www.bid-on-equipment.com

C606

C606 Heat Treatment Combination Shake and Soft Serve Freezer

Showing Optional Cup & Cone Dispenser X59489

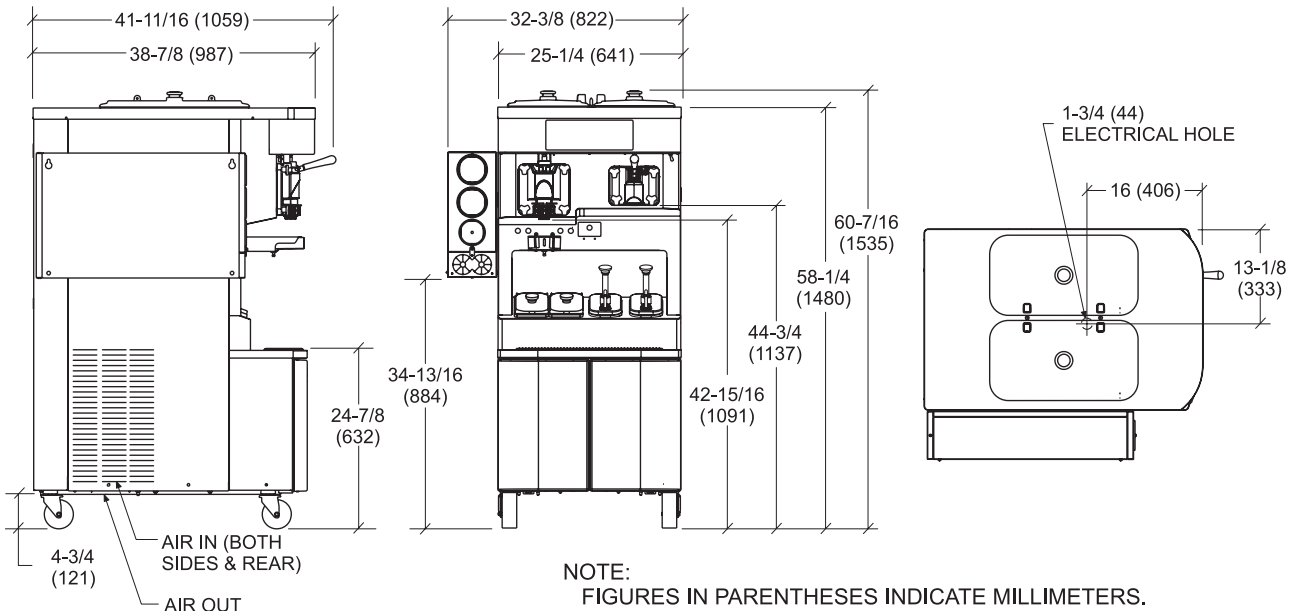

TOP VIEW - OPERATOR END
ALL CONNECTIONS LOCATED UNDERSIDE OF BASE

Weights	lbs.	kgs.
Net	815	369.7
Crated	1046	474.5
	cu. ft.	cu. m.
Volume	66.5	1.88

Dimensions	in.	mm.
Width	25-1/4	641
Depth	38-7/8	987
Height	60-7/16	1535
Floor Clearance	4-3/4	121

Mounted on standard casters

Electrical	Maximum Fuse Size	Minimum Circuit Ampacity	Poles (P) Wires (W)
208-230/60/1 Air	60	50	2P 3W
208-230/60/3 Air	45	35	3P 4W
208-230/60/3 Water	45	35	3P 4W
220-240/50/3 Air	45	35	3P 4W
380-415/50/3N~ Air	35	31	4P 5W
380-415/50/3N~ Water	35	31	4P 5W

Other electrical characteristics may be available.
(For exact electrical information, always refer to the data label of the unit.)

Bidding Specs

Electrical: Volt _____ Hz _____ ph _____
Neutral: Yes No Cooling: Air Water NA

Options: _____

Specifications

Electrical

One dedicated electrical connection is required. See the Electrical chart for the proper electrical requirements. Manufactured to be permanently connected. Consult your local Taylor distributor for cord & receptacle specifications as local codes allow.

Beater Motor

Shake, 1.0 HP; Soft Serve, 1.5 HP

Refrigeration System

Shake, 11,000 BTU/hr.; Soft Serve, 9,500 BTU/hr. R404A (BTUs may vary depending on compressor used.)

Air Cooled

Minimum 3" (76 mm) around all sides. Install the deflector provided to prevent recirculation of warm air. Minimum air clearances must be met to assure adequate air flow for optimum performance.

Options

- Cup & Cone Dispenser
- Hopper Locks
- Syrup Tanks

Continuing research results in steady improvements; therefore, these specifications are subject to change without notice.



Taylor Company,
A Division of Carrier Commercial Refrigeration, Inc.
Rockton, Illinois 61072
815-624-8333 800-255-0626 Fax 815-624-8000
www.taylor-company.com

Packaging - Processing
Bid on Equipment
1-847-683-7720
www.bid-on-equipment.com