

794

Soft Serve Freezer

Twin Twist

Features

Offer all the popular soft serve variations from low or non-fat ice creams to custards, yogurt and sorbet. Serve two separate soft serve flavors, or an equal combination of both in a twist.

Freezing Cylinder

Two, 3.4 quart (3.2 liter).

Mix Hopper

Two, 14 quart (13.2 liter). Separate hopper refrigeration (SHR) maintains mix below 41°F (5°C) during Auto and Standby modes.

Indicator Lights

Mix Low light alerts operator to add mix.

Electronic Controls

Softech™ is our exclusive microprocessor based master control that regulates refrigeration by measuring product viscosity to maintain consistent quality.

Standby

During long no-use periods, the standby feature maintains safe product temperatures in the mix hopper and freezing cylinder.

Drain Assembly

A drain assembly, less funnel, is provided to simplify the cleaning process. A drain line, connected under the drip tray connects to a 1 FPT coupling in the base pan to drain rinse water directly into the floor drain.



Standard 6



SA2650



Selected 50 Hz. Models

794 Soft Serve Freezer

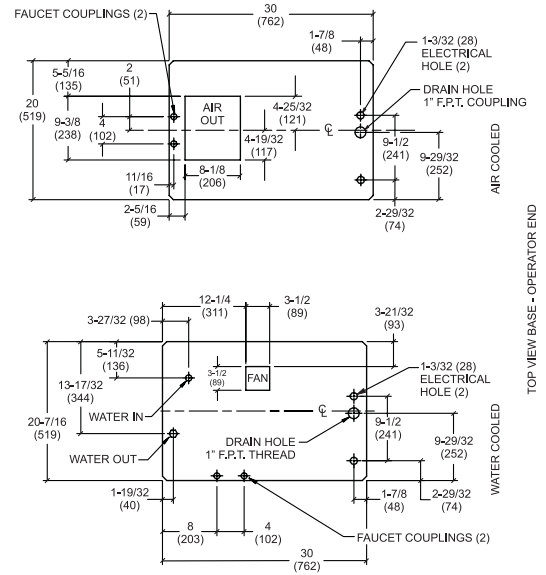
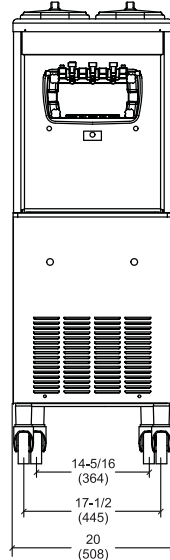
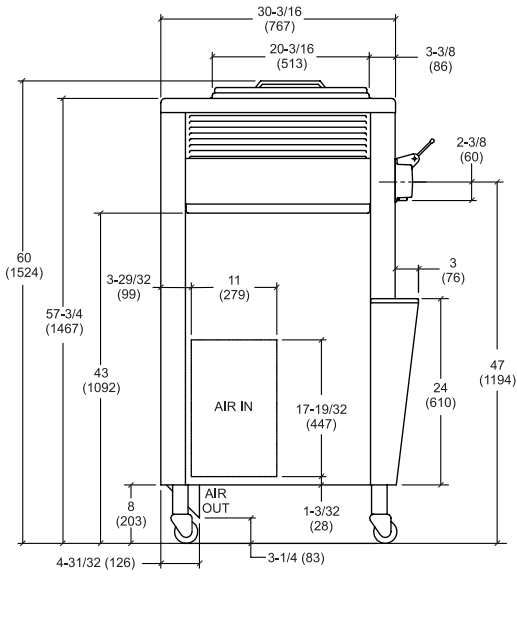

FIGURES IN PARENTHESES INDICATE MILLIMETERS.

Weights	lbs.	kgs.
Net	610	276.7
Crated	675	306.2
	cu. ft.	cu. m.
Volume	47.5	1.34

Dimensions	in.	mm.
Width	20	508
Depth	30-3/16	767
Height	60	1524
Floor Clearance	8	203

*Mounted on standard casters

Electrical	Maximum Fuse Size		Minimum Circuit Ampacity		Poles (P) Wires (W)
	Left	Right	Left	Right	
208-230/60/1 Air	35	35	27	23	2P 3W
208-230/60/1 Water	35	35	25	23	2P 3W
208-230/60/3 Air	25	20	19	15	3P 4W
208-230/60/3 Water	20	20	17	15	3P 4W
220-240/50/1 Air	30	25	23	19	2P 3W
380-415/50/3N~ Air	12	10	12	8	4P 5W

This unit may be manufactured in other electrical characteristics. Refer to the local Taylor Distributor for availability.
(For exact electrical information, always refer to the data label of the unit.)

Bidding Specs

Electrical: Volt _____ Hz _____ ph _____
Neutral: Yes No Cooling: Air Water NA

Options: _____

Specifications

Electrical

Two dedicated electrical connections are required. See the Electrical chart for the proper electrical requirements. Manufactured to be permanently connected. Consult your local Taylor distributor for cord & receptacle specifications as local codes allow.

Beater Motor

Two, 1.5 HP.

Refrigeration System

Two, 9,500 BTU/hr. R404A.

Separate Hopper Refrigeration (SHR), One, 400 BTU/hr. R134a.
(BTUs may vary depending on compressor used.)

Air Cooled

Minimum 3" (76 mm) around all sides. Install the deflector provided to prevent recirculation of warm air. Minimum air clearances must be met to assure adequate air flow for optimum performance.

Water Cooled

Water inlet and drain connections under side of base 1/2" FPT.

Options

- Cone Dispenser
- Drain Funnel
- Draw Valve Lock Kit
- Faucet
- Mix Low Chime
- Sneeze Guard
- Syrup Rail Kit (side mount)

Continuing research results in steady improvements; therefore, these specifications are subject to change without notice.



Taylor Company,
A Division of Carrier Commercial Refrigeration, Inc.
Rockton, Illinois 61072
815-624-8333 800-255-0626 Fax 815-624-8000
www.taylor-company.com

Packaging - Processing
Bid on Equipment
1-847-683-7720
www.bid-on-equipment.com