

342

Frozen Uncarbonated Beverage (FUB) Freezer

Two Flavor

Features

Vary your menu by offering smoothies or frozen cocktails, fruit juices, coffees, cappuccino and tea slush beverages, all served at the desired thickness.

Freezing Cylinder

Two, 7 quart (6.6 liter).

Mix Hopper

Two, 20 quart (18.9 liter). Optional refrigerated hopper approved for dairy products.

Indicator Light

Add Mix light alerts the operator to add mix.

Automatic Consistency Control

A specially designed viscosity control automatically maintains superior product quality. Adjustable control allows the operator to serve a wide variety of frozen beverages at the desired thickness.



Rockton, Illinois 61072
800-255-0626
Phone 815-624-8333 Fax 815-624-8000
www.taylor-company.com
e-mail: info@taylor-company.com

International Office
Taylor Company S.r.l.
Roma, Italy
Tel: **+39-06-420-12002** Fax: +39-06-420-12034
e-mail: romeoff@taylor-company.com

Packaging - Processing
Bid on Equipment
1-847-683-7720
www.bid-on-equipment.com

342 Frozen Uncarbonated Beverage (FUB) Freezer

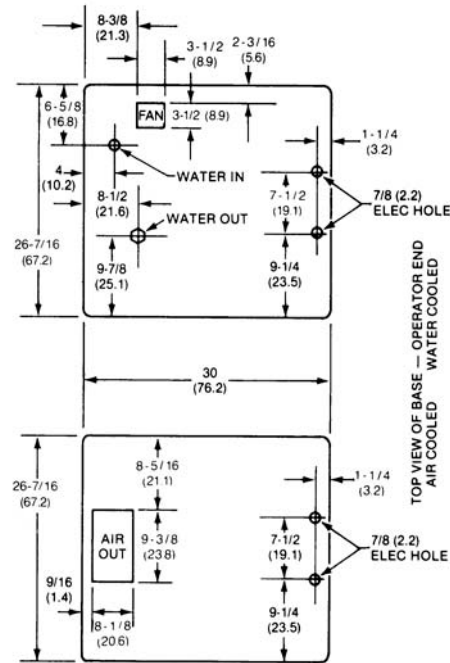
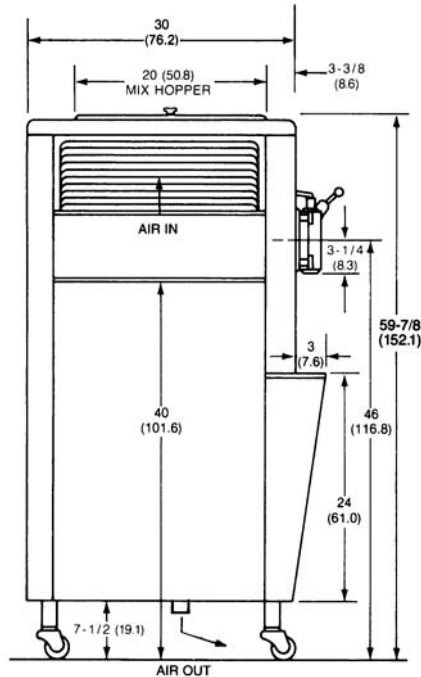

Weights	lbs.	kgs.
Net	519	235.4
Crated	609	276.2
	cu. ft.	cu. m.
Volume	48.1	1.3

Dimensions	in.	mm.
Width	26-7/16	672
Depth	33	838
Height	59-7/8	1521
Counter Clearance	7-1/2	191

*Mounted on standard casters

Electrical	Maximum Fuse Size		Minimum Circuit Ampacity		Poles (P) Wires (W)
	Left	Right	Left	Right	
115/60/1 Air	40	30	29	21	2P 3W
208-230/60/1 Air	20	20	16	13	2P 3W
208-230/60/1 Water	20	20	14	13	2P 3W
208-230/60/3 Air	15	15	13	9	3P 4W
220-240/50/1 Air	15	15	14	10	2P 3W
380-415/50/3N~ Air	10	7	9	6	4P 5W

This unit may be manufactured in other electrical characteristics. Refer to the local Taylor Distributor for availability. (For exact electrical information, always refer to the data label of the unit.)

Bidding Specs

Electrical: Volt _____ Hz _____ ph _____
 Neutral: Yes No Cooling: Air Water NA

Options: _____

Specifications

Electrical

Two dedicated electrical connections are required. See the Electrical chart for the proper electrical requirements. Manufactured to be permanently connected. Consult your local Taylor distributor for cord & receptacle specifications as local codes allow.

Beater Motor

Two, 1/4 HP

Refrigeration System

Two, 7,500 BTU/hr. R404A. (BTUs may vary depending on compressor used.)

Air Cooled

Minimum 3" (76 mm) around all sides. Install the deflector provided to prevent recirculation of warm air. Minimum air clearances must be met to assure adequate air flow for optimum performance.

Water Cooled

Water inlet and drain connections under side of base 1/2" FPT.

Options

- Available as Model 342D, with Refrigerated Hopper, 1/2 HP Beater Motor, Beater Cycle Timer. Maintains mix below 41°F (5°C). Approved for dairy and non-dairy products.
- Remote Auto Fill System
- Syrup Jars and Brackets

Continuing research results in steady improvements; therefore, these specifications are subject to change without notice.



Taylor Company,
 A Division of Carrier Commercial Refrigeration, Inc.
 Rockton, Illinois 61072
 815-624-8333 800-255-0626 Fax 815-624-8000
 www.taylor-company.com

Packaging - Processing
Bid on Equipment
 1-847-683-7720
 www.bid-on-equipment.com