

SWECO® PAPER COATINGS RECTANGULAR SEPARATOR

IMPROVES COATING QUALITY

The Sweco Paper Coating Rectangular Separator can filter slurried coating ingredients, blended virgin coatings, and return coatings containing fiber contaminants. With the ability to remove grit and fiber, the Sweco Paper Coating Separator reduces the chances of scratches and other defects in your coated papers. Our CIP design with 360 degree spray clusters provides automated cleaning of screen mesh and internal surfaces to prevent screen blinding and accumulation of hard coating.

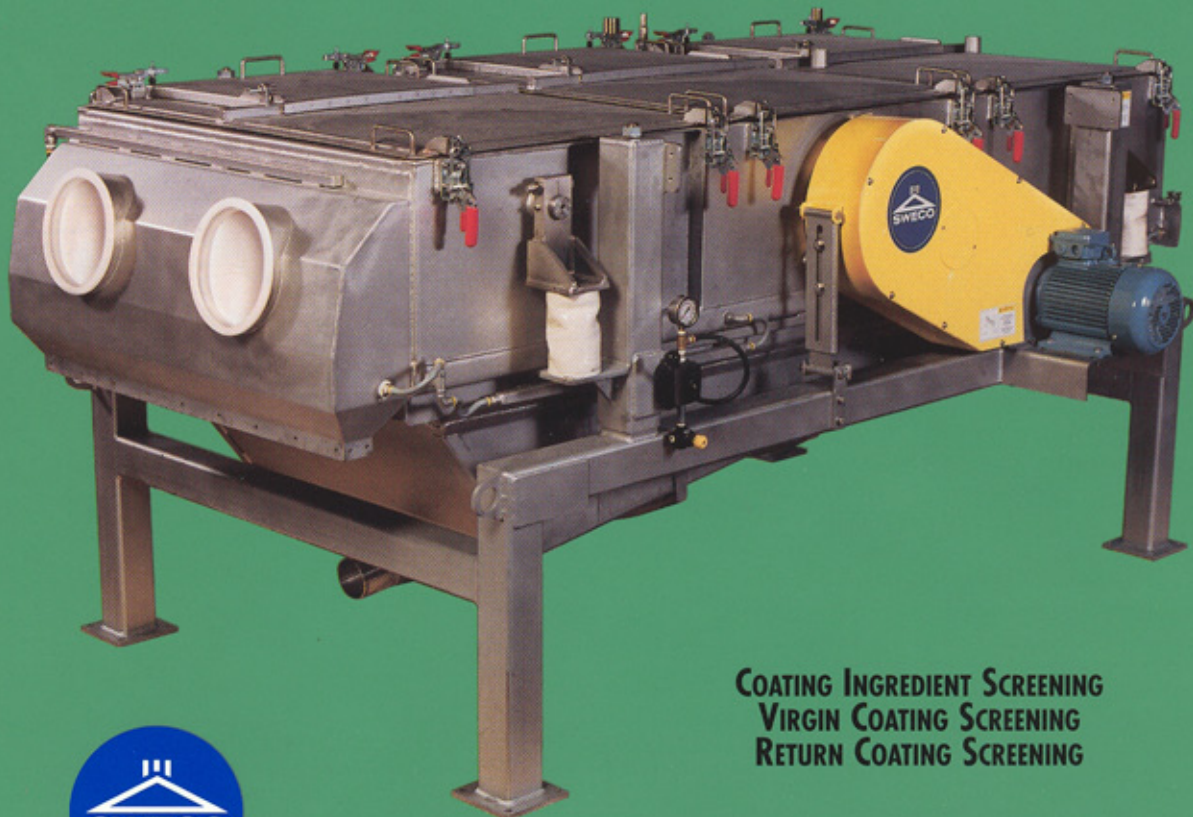

COATING INGREDIENT SCREENING
VIRGIN COATING SCREENING
RETURN COATING SCREENING



We Put Technology In Motion™

www.sweco.com

Packaging - Processing
Bid on Equipment

1-847-854-8577

www.bid-on-equipment.com

TOTALLY ENCLOSED AUTOMATIC INTERNAL WASHING

Packaging - Processing

Bid on Equipment

1-847-854-8577

www.bid-on-equipment.com

STANDARD FEATURES:

- PATENTED PNEUMATIC SCREEN SEALING SYSTEM
- NO TOOLS SCREEN CHANGE
- FULLY ENCLOSED, SPLASH TIGHT CONSTRUCTION
- CIP INTERNAL WASH SYSTEM
- ALL PRODUCT CONTACT SURFACES RA ≤ 1.0 MICRON FINISH
- INTEGRAL REJECT OVERFLOW DAM
- STEAM INJECTION PORTS

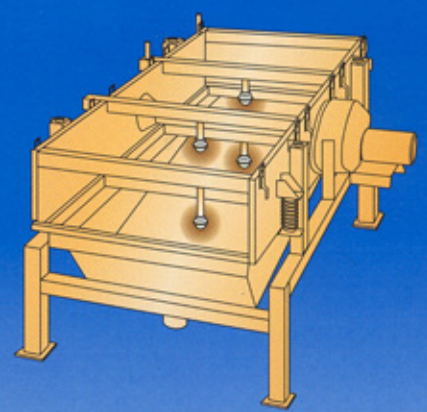

- **Prevents coating from drying** - The controlled environment maintains humidity preventing coating from drying on the screen or walls of the separator. This gives greater throughput, minimizes potential for dried coating contamination and improves screen life. Further, the external environment is kept clean of coating.
- **Maximizes capacity** - The integral overflow dam allows flooding of the screen with coating. The full screen surface can be used for screening while not losing good coating to the reject stream. This effectively increases throughput of the separator allowing maximum amount of coating to be screened.
- **Improved product quality** - The patented pneumatic sealing allows zero-bypass of oversized particles and fibers. In addition our Supertaut[®] Plus screens give exacting grit specifications keeping your coating quality consistent.
- **Reduced costs** - Our screening system allows for a single operator to change screens quickly without the need of any tools. This means less downtime and lower operational costs.
- **Automated cleaning** - The integral CIP wash system allows for cleaning of all machine surfaces between batches. The high polish finish facilitates cleanup. This minimizes the potential for bacteria contamination.

CIP WASH SYSTEM:

- FOUR 360 DEGREE WASH CLUSTERS EACH WITH 12 NOZZLES
- EIGHT POINT SEAL TRACK WASH
- THREE POINT REJECTS CHUTE WASH
- SINGLE INLET CONNECTION FOR ALL NOZZLES, SEAL TRACK AND REJECT CHUTE WASHERS
- FIVE POINT REJECT WASH-OFF SPRAY
- FOUR POINT SCREEN MIST SPRAY

Overall Dimensions: Width 1910mm/75", Length 3170mm/125", Height 1450mm/57" Approx. shipping weight 1300kg/3000lbs.



We Put Technology In Motion™
• e-mail: info@sweco.com