

# Universal Machine UM 60 E

- Size Reduction
- Mixing
- Emulsifying



## Typical Applications:

- Mayonnaise
- Ketchup
- Dressings, Dips
- Baby Food
- Chocolate fillings
- Fish Plates

## Advantages:

- Stable emulsions
- Short batch times
- Homogeneous mixing
- Constant product quality
- User-friendly
- Easy to clean

## Options:

- Bowl with double jacket
- Soft touch keyboard with timer
- Vacuum unit
- Additional working tools

**Dimensions UM 60 E:**

overall height with lid open: 1600 mm

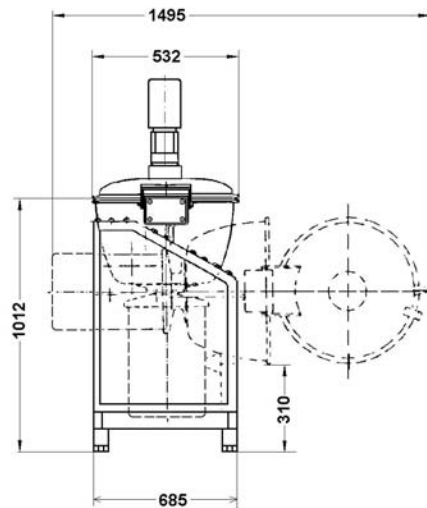
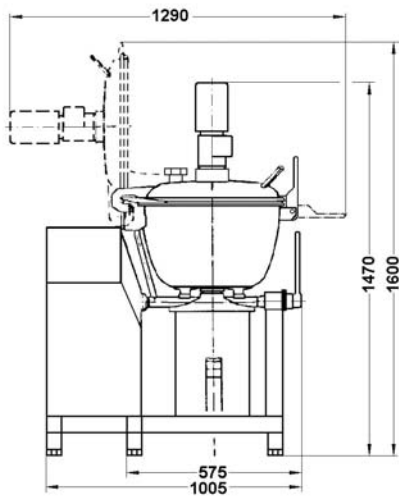

**Machine Data:**

Bowl capacity	(l) approx.	60
Batch size depending on product	l	40
Weight of the machine net	kg	250
Max. permissible operating temperature bowl	°C (°F)	95/203
Max permissible operating excess pressure bowl	bar (PSI)	0.0/0.0
Control voltage	V	24 DC
Fuse protection 400V	A (time-lag fuse)	35

**Energy requirement:**

Main motor n = 1500/3000 rpm	kW	5.5/7.5
Supply voltage/frequency	V/Hz	400/50