

NEW Continuum™



Continuous Motion Shrink Wrapper

Standard Knapp
Standard Knapp

an EMPLOYEE owned company

StandardKnapp
StandardKnapp
an EMPLOYEE owned company

Continuum™ Shrink Wrapper

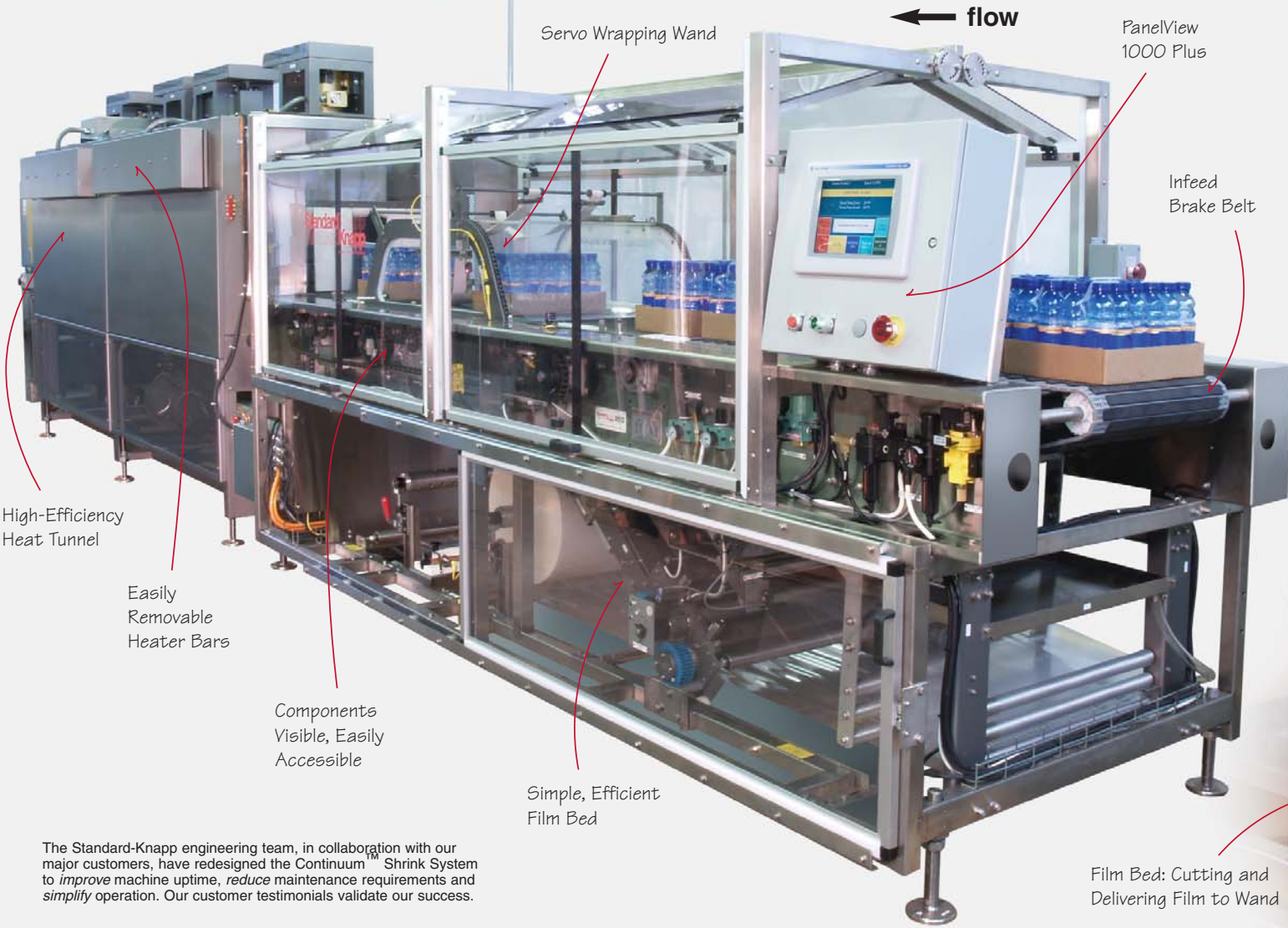

Continuum™ Benefits

- **High reliability** – designed for 24/7 operation
- **Simple operation** and intuitive operator interface
- **Easy walk-by maintenance** – all components are visible and accessible
- Positive infeed metering system
- **Smart innovation** including an “on demand” servo wrapping wand
- **Flexible and adaptable** to future applications
- **Quality fit and finish** – robust construction

The Standard-Knapp engineering team, in collaboration with our major customers, have redesigned the Continuum™ Shrink System to *improve* machine uptime, *reduce* maintenance requirements and *simplify* operation. Our customer testimonials validate our success.

Film Bed: Cutting and Delivering Film to Wand

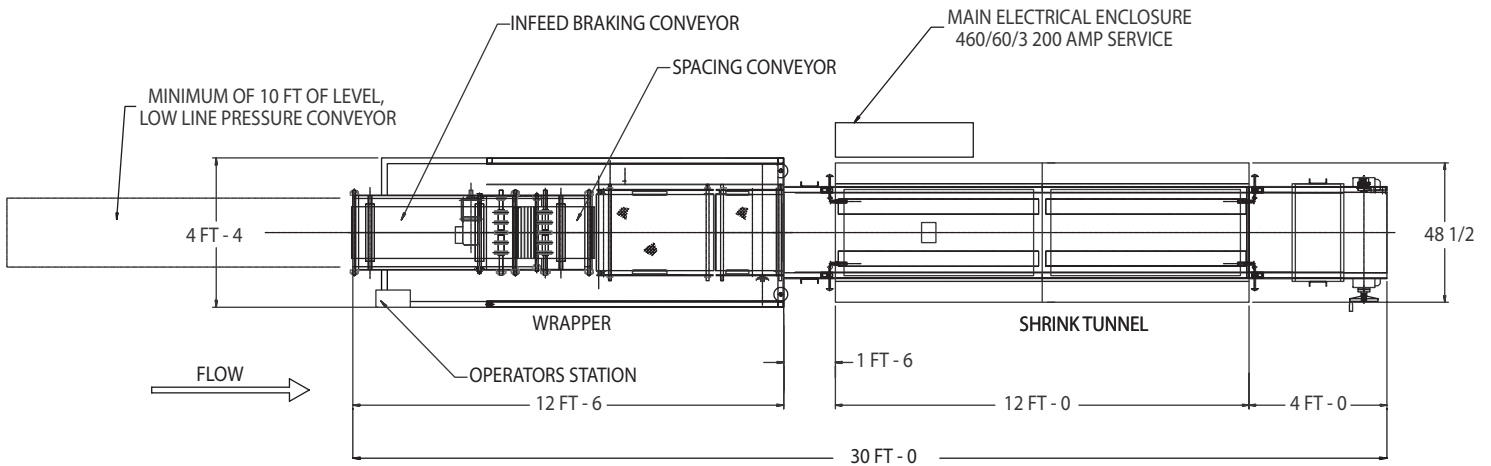

Continuum™ Floor Plan

Specifications*

Model: 596s
Speeds: 60, 80 TPM
Controls: Allen-Bradley ControlLogix
Servo Drives: Ultra 3000 or Kinetics
Interface (HMI): PanelView 1000 Plus
Electrical Supply: 200 AMP drop
Air Supply: 80 psi with 1/2 NPT

Motors:
Main drive: 2 HP
Tunnel: 2 HP
Wrapper: Servo
Film Feed: Servo
Infeed Metering: Powerflex 40 VFD

* Standard-Knapp is committed to continuous product improvement. Specifications are subject to change without notice.



STANDARD-KNAPP, INC.

63 Pickering Street, Portland, CT 06480 U.S.A.

SALES PHONE: (860) 342-1100, ext. 239

SALES FAX: (860) 342-1557

EMAIL: info@standard-knapp.com

WEB SITE: www.standard-knapp.com