

# SEALSTAR<sup>T.M.</sup>

**THE COMPACT  
AND ECONOMICAL  
NEW HOT MELT  
CASE SEALING  
SYSTEM.**

**457F-HM  
457B-HM**

STANDARD  
KNAPP

SEALSTAR

**Packaging - Processing  
Bid on Equipment**

**1-847-854-8577**

**[www.bid-on-equipment.com](http://www.bid-on-equipment.com)**

## **2 LOW-COST, STANDARD MACHINES THAT LEAD THE FIELD IN SPACE-SAVING AND PERFORMANCE.**

### **TOP AND BOTTOM FLAPS 457F-HM**

Cases are conveyed by flight bar at speeds from 20-40 cpm.

### **TOP FLAPS ONLY. 457B-HM**

A belt delivery machine that seals top flaps at speeds of 20 to 50 cpm.

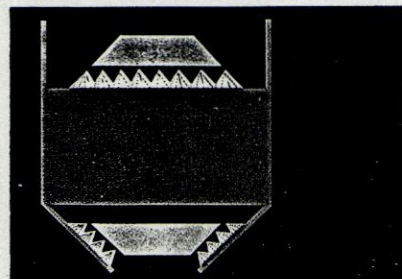

The new Sealstar line was developed to meet industry demand for a standard, low-priced machine that would handle a wide range of case sizes, economically.

We believe that Sealstar is the most space-efficient, hot melt sealer on the market today. And because we designed it specifically as a standard machine, to handle only your most frequently encountered case sealing applications, we are able to build it without the myriad of accessories and options that bring cost up — in initial purchase, operation, and maintenance.

Best of all, because it's a standard machine, it's in-stock, assuring fast shipment, off-the-shelf, and rapid spare parts replacement.

It's the industry's #1 sealer buy.

### **THE ADVANTAGES OF HOT MELT**

The new Sealstar is designed to give packers of RSC cases of all types the inherent advantages of hot melt application.

- It's fast: 1-2 second set increases production speed over cold systems. Shortened compression cycle saves floor space.
- Overcomes board imperfections — spreads out, filling voids.
- Penetration-seals coated materials.
- Cuts dollar loss in glue handling, shipping and storage.
- It's unaffected by environmental conditions such as temperature and humidity.

# FEATURES

## NEW REDUCED LENGTH

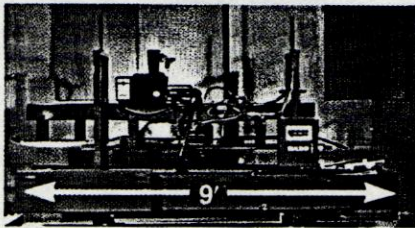

Sealstar's new short profile puts it into tight production areas where other machines won't go. Maximum length is 9' in top-seal-only model; 11'3" in top-and-bottom-seal unit.

## MINIMUM FLAP OPENING & CLOSING SHORTENS CYCLE

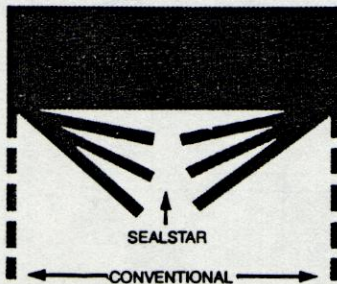

Sealstar's unique "tent" flap position means that flaps are swung open a shorter distance to receive glue application. And travel less distance to close and seal.

## PRECISION GLUE APPLICATION

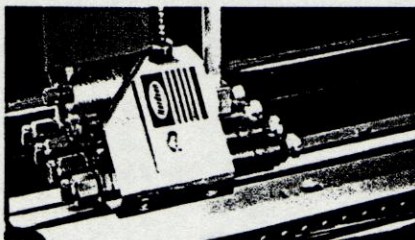

New low-profile glue head offers a precise glue bead distribution pattern to the flaps. Adjustable to the specific case design. Unique design reduces product-damage and contamination from glue.

At top of case, inner flaps receive glue pattern; At case bottom, outer flaps receive glue pattern.

## NUMBER-CODED PARTS

Stamped number on each machine part makes replacement easier, faster.

## FAST, POSITIVE CASE FEED

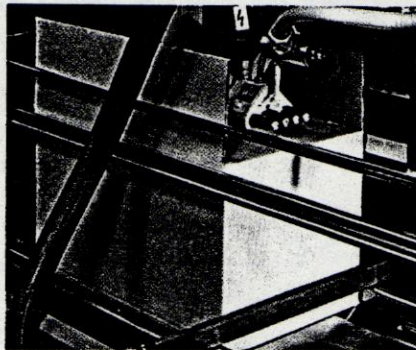

Sealstar is available with one of two types of case transfer system. Top-only models have high-traction belt drive, while top-and-bottom-sealing models utilize positive-control flight bar.

## WIDE RANGE OF CASE SIZES

Sealstar takes a broad combination of case heights, widths, and lengths from 8"-23" long, 7"-18" wide and 4"-20" high. Easily adjustable.

## OPERATOR-ADJUSTABLE FROM LEFT OR RIGHT



Conveniently located operator's station with L or R option puts complete control and case size adjustment in one place. All adjusting screws are nickel plated for rust-free operation.

## 24" BUILT-IN COMPRESSION UNIT



Short compression unit is integral part of Sealstar — not an "add-on", tightly seals case without adding to overall length. Foam compression shoe conforms to any board surface irregularity. Holds, seals flaps tightly. Teflon coating reduces friction, preventing product scuffing, marring.

## SIMPLIFIED MACHINE LEVELING

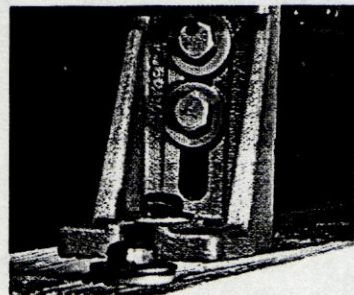

Adjustable feet permit quick leveling of machine to handle uneven floor conditions.

## LINE JAM SAFETY

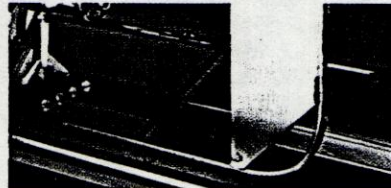

Pressure-sensitive switch detects jam and shuts down machine, protecting product from damage.

## AUTOMATIC CASE SPACING

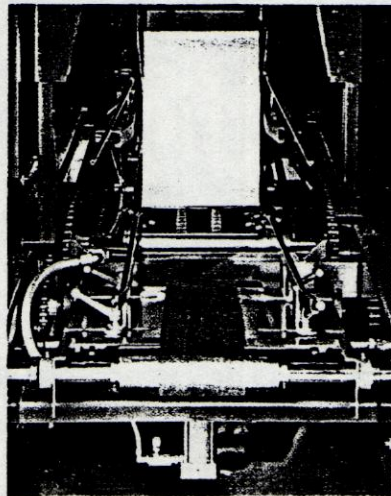

Lift-type timer engages full width of case, preventing product damage while feeding cases into carrier bar to insure proper case spacing.

## NICKEL PLATING PROTECTS PRODUCTS

Bright nickel interior stays clean, rust-free, prevents product damage.

Packaging - Processing  
**Bid on Equipment**

1-847-854-8577

[www.bid-on-equipment.com](http://www.bid-on-equipment.com)

# SEALSTAR

T.M.

## SPECIFICATIONS

### 457F-HM

**SEALING MODE:** Top and Bottom flaps  
**MOTOR:** ¼ HP. 25:1 gearbox  
**VOLTAGE:** 220/440 — 60-3  
**AIR:** 1.3 CFM at 40-45 psi at 15 CPM  
**POWER:** 4750 Watts  
**WEIGHT:** 1950 lbs.  
**HOT MELT UNIT:** Nordson V  
**CASE SIZE RANGE**

	MIN	MAX
Length	8"	23"
Width	7"	18"
Height	4"	20"

**FOR OPTIONAL EQUIPMENT, SEE PRICE LIST**

**NOTE:** Floor plan to ¼ scale for convenient template use.

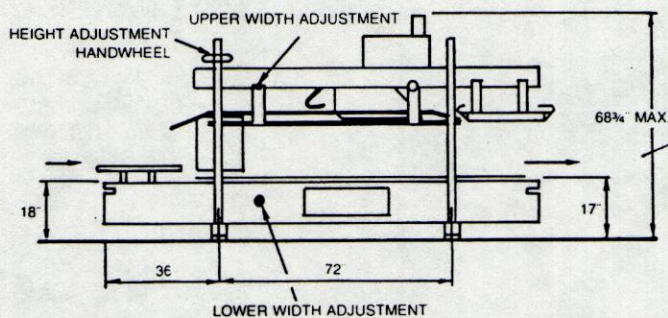
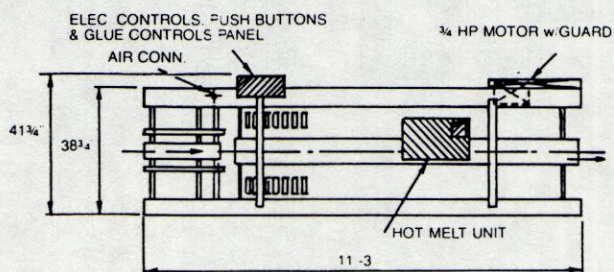

### 457B-HM

**SEALING MODE:** Top flaps  
**MOTOR:** ¼ HP. 25:1 gearbox  
**VOLTAGE:** 220/440 — 60-3  
**AIR:** 1.3 CFM at 40-45 psi at 15 CPM  
**POWER:** 4750 Watts  
**WEIGHT:** 1750 lbs.  
**HOT MELT UNIT:** Nordson V  
**CASE SIZE RANGE**

	MIN	MAX
Length	8"	23"
Width	7"	18"
Height	4"	20"

**FOR OPTIONAL EQUIPMENT, SEE PRICE LIST**

**NOTE:** Floor plan to ¼ scale for convenient template use.

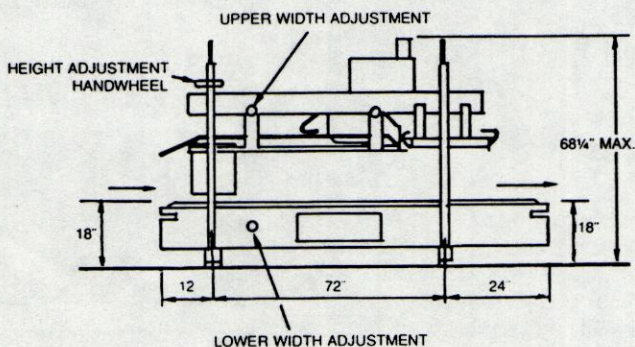
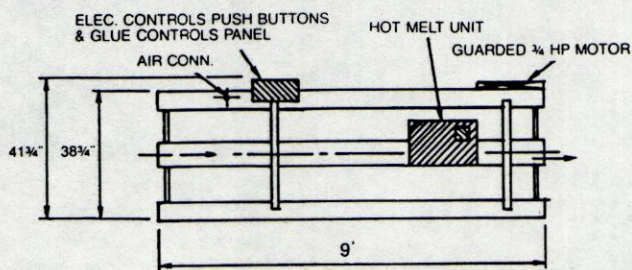

# STANDARD KNAPP



STANDARD-KNAPP DIVISION, EMHART CORPORATION

SALES SERVICE: CALIFORNIA: Los Altos, Los Angeles; COLORADO: Denver, Rosemont; MASSACHUSETTS: Worcester; MINNESOTA: St. Paul; NEW YORK: Englewood Cliffs; NORTH CAROLINA: Greensboro; TEXAS: Houston; WASHINGTON: Seattle;

Packaging - Processing  
**Bid on Equipment**

1-847-854-8577

[www.bid-on-equipment.com](http://www.bid-on-equipment.com)