



**Waukesha  
Cherry-Burrell**  
A Unit of SPX Process Equipment

## Operation and Maintenance Manual

*Votator*<sup>®</sup>  
CR MIXER



**Read and understand this manual  
prior to installing, operating or servicing this equipment**

---

# VOTATOR CR MIXER

## TABLE OF CONTENTS

Page No.		
2	Section I	Receiving and Handling
3-4	Section II	Design Features and Specifications
5	Section III	Installation
6-7	Section IV	Process
8	Section V	Operation
9	Section VI	Disassembly and Assembly
10	Section VII	Care of Votator CR Mixer
10	Section VIII	General Maintenance
11-12		Troubleshooting

---

## SECTION I

# Receiving and Handling

1. Carefully inspect the equipment for damage immediately upon receipt.
2. It is your responsibility to file a damage claim with the carrier immediately.
3. Cover and store in a safe, clean, dry place if the equipment is not to be installed immediately.
4. During all movement, protect the equipment from sudden jars, shocks, dropping, etc.

## SECTION II

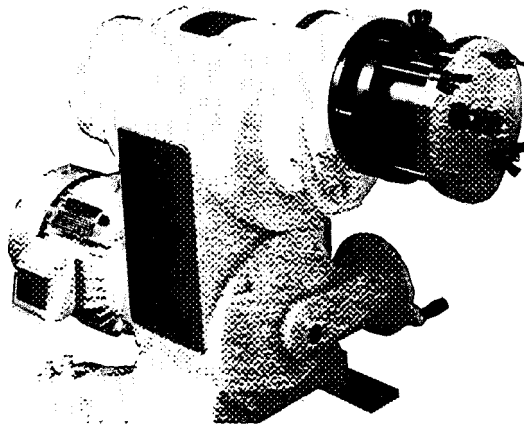

### DESIGN FEATURES OF 6" VOTATOR CR MIXER WHIPPER-EMULSIFIER WITH OR WITHOUT JACKETING

- CONSTRUCTION:** 316 Stainless Intermeshing Pins machined into heads and rotor.
2. **OPERATING PRODUCT PRESSURE:** Up to 300 psig unjacketed. 250 psig jacketed.
  3. **ROTOR DRIVE:** Standard is 5 HP TEFC. 230/440 volts. 60 cycle. 3 phase. variable RPM range to suit. CR rotor directly coupled to drive Other drive arrangements are available
  4. **PRODUCT SHAFT SEAL:** Rotary seal. Water flushed and cooled.
  5. **PRODUCT CONNECTIONS:** 1" Cherry-Burrell S-clamp. Other types of fittings and multiple inlets for individual metering of components can be provided.
  6. **AIR OR GAS INJECTION:** Available as a complete system package including product pump(s), back pressure valve, injection controls and with or without Votator Scraped Surface Heat Exchanger. Mixer unit with pump, valves. injection controls on common stand also available at extra cost.
  7. **SANITARY FEATURES:** Designed for quick disassembly; cylindrical rotor housing sealed between heads containing removable o-ring seals.
  8. **WHIPPING-MIXING PINS:** Stationary pins in each head intermesh with moving pins in two rotor plates sandwiching the rotor impellers.
  9. **OVERALL DIMENSIONS:** See prints for dimensions.
  10. **UNIT WEIGHT:** 425 pounds; Crated: 475 pounds
  11. **PRODUCT VOLUME:** 65 cubic inches.
  12. **JACKETED HOUSING:** Designed for 2 to 3 GPM of Coolant @ 50 psig maximum.

95-03071

## SECTION II

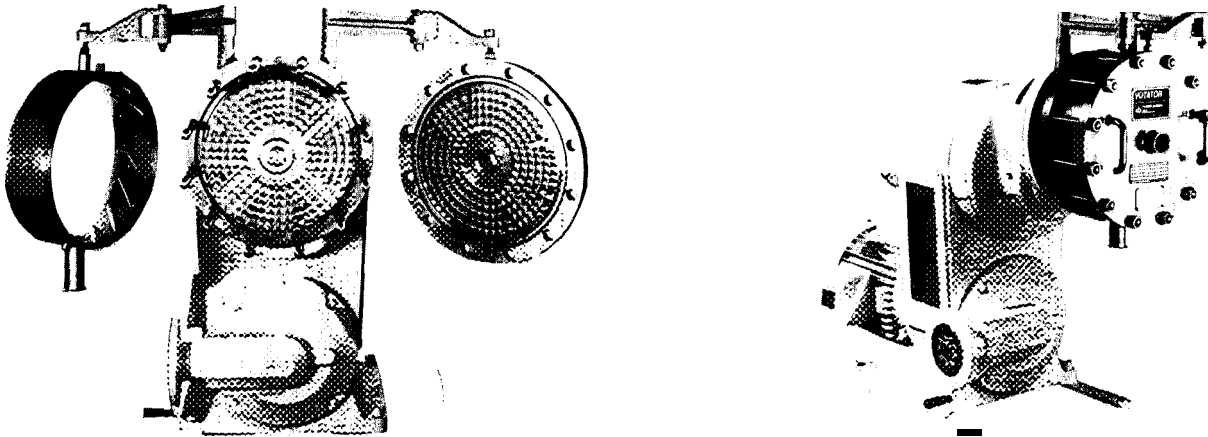

### DESIGN FEATURES OF THE JACKETED 16" VOTATOR CR MIXER WHIPPER-EMULSIFIER

**CONSTRUCTION:** 316 Stainless. Intermeshing Pins machined into heads and rotor.

2. **OPERATING PRODUCT PRESSURE:** 250 psi @ 100°F, 200 psi @ 300°F for jacketed mixer. For unjacketed mixer 300 psi @ 300° F.
3. **ROTOR DRIVES:** Standard is 10 to 50 HP, TEFC, variable RPM for 230/460 volts, 3 phase, 60 cycle. Other drive arrangements are available.
4. **PRODUCT SHAFT SEAL:** Rotary seal, water flushed and cooled.
5. **PRODUCT CONNECTIONS:** 2" Cherry-Burrell S-clamp; Multiple inlets for individual metering can be provided.
6. **AIR OR GAS INJECTION:** Available as a complete system package including product pump(s), back pressure valve, injection controls, and with or without Votator Scraped Surface Heat Exchanger. Mixer unit with pump, valves, injection controls on common stand also available at extra cost
7. **SANITARY FEATURES:** Front heads and rifled cylindrical housing, double-hinged for complete swing-out for cleaning and maintenance. Housing sealed between heads with removable o-rings
8. **WHIPPING-MIXING PINS:** 240 in each head intermeshing with pins in two rotor plates sandwiching the rotor impellers.
9. **UNIT WEIGHT:** 1300 to 2500 pounds, Crated. 1400 to 2600 pounds.
10. **VOLUME:** 716 cubic inches.
11. **JACKETED HOUSING:** Designed for 5 GPM coolant flow at 50 psig maximum.
12. **OVER-ALL DIMENSIONS:** See prints for dimensions.

4

95-03071

## SECTION III

# Installation

### A. Location

1. **Space Requirement:** The floor space requirement for the equipment in its operating position is shown on the drawings. Provide sufficient clearance around and above the unit for access and maintenance work.
2. **Other Equipment:** Carefully plan location of Votator equipment in relationship to complementary equipment so as to arrive at the optimum processing arrangement.
3. **Utility Requirements:**
  - a. **Current Characteristics:**  
\_\_\_\_\_ Volts                      Phase  
\_\_\_\_\_ Cycles      Total HP      \_
  - b. **Seal Lubrication:** City water is usually sufficient at approximately 1/4 GPM.
  - c. **Compressed Air or Nitrogen:** For pneumatic back pressure valve (if applicable) and product aeration as required.
4. **Ambient Conditions:** It is not desirable to locate the equipment in a corrosive or extremely dusty atmosphere. If outdoor installation is contemplated, protection from the elements and from freezing conditions must be considered.

### B. Foundation

A concrete pad or substantial steel structure is advised. Anchor bolt or foot locations are shown on the drawings where applicable.

### C. Electrical Power Connections

(See Wiring Diagram)

Provide the following items in the branch electrical circuit from the line to the drive motor(s):

1. **Motor Controller** properly sized to protect the motor against overload.
2. **Safety Switch** ahead of the motor controller to disconnect the equipment from the line while it is being maintained.
3. **Fuses or Circuit Breaker** to protect the branch against short circuits or grounds which may result in an overcurrent far in excess of the motor rating.
4. **Start-Stop Switch** installed in the control circuit for easy operational control of the motor(s).
5. **Direction of Rotation** is stamped on the front of the unit.

### D. Product Piping

1. Refer to drawings for size and location of piping.
2. Support **ALL** piping independently.
3. Provide for line expansion and contraction.
4. A safety valve should be properly located and installed in the system to protect the equipment and personnel. (See operating pressure rating of equipment.)
5. Keep piping as short and as free of directional changes as possible.
6. Do not install any positive shut off valves downstream of Votator unit.

7 Provide temperature indicators on both sides of Votator unit Provide a pressure gauge on the discharge side of the pump

2 Choose flushing medium compatible with product.

**NOTE**

City water at 1/4 to 1/2 GPM is usually sufficient for flushing a seal. However, more or less water and possibly hot water or some other medium may be required to keep the seal clean.

**E. Seal Flushing**

1. The connection size is indicated on assembly drawing

## SECTION IV

# Process

### 1. Design of the CR Mixer

This simple but unique device achieves its purpose of continuous mixing, blending, dispersing and whipping by applying some known characteristics of the centrifugal pump. Therefore, unlike other known types of in-line continuous mixers, a primary feature of the VOTATOR CR Mixer is its ability to cause the materials in process to pass through the zone of intermeshing pins, not once, but many times during their "residence" within the mixer.

The mixer's rotor is a multi-vaned impeller sandwiched between two discs. The disc facing the mixer outlet head is solid. The disc facing the vari-drive motor has openings adjacent to the rotor drive shaft. The discs are provided with pins which mesh closely with fixed sets of pins placed into the heads. These two heads plus a cylindrical housing contain this rotor assembly.

Materials enter the mixer through the cylindrical housing inlet. They are pulled through the forest of pins into the inner disc openings. The impeller blades exposed by the inner disc openings pick up and centrifugally "sling" product to rotor periphery. Here the materials are redirected to the inner suction at rotor shaft.

This redirection is accomplished in two ways. First, by sweeper vanes installed in the cylindrical housing. Second, by making the resistance to flow at the mixer's outlet greater than the resistance between the periphery of the rotor impellers and the inner disc openings. Although imposing a back pressure at the mixer outlet will increase the pressure within the whole mixer, a characteristic pressure differential always exists between the impeller discharge at the periphery and the intake at rotor center. Thus, regardless of the net flow of the product through the system, the material in process is made to circulate and recirculate through the primary zone, past rotor vanes out to periphery and back through the primary zone. The number of cycles can be controlled while the mixer is in operation and does not alter the net flow of product from supply tank to discharge opening. This recirculation or recycling is further controlled by changing the speed of the rotor. As the rotor speed (RPM) is increased, so is the rotor suction and the mechanical action.

All of the above assumes a constant flow of material from a supply tank by means of a positive displacement pump whose flow must not be affected by altering either of the variables discussed above.

In summary, one way of expressing action within this mixer is that each particle can be made to turn back to the primary mixing zone a multiplicity of times in order to increase its subjection to mixing or beating action.

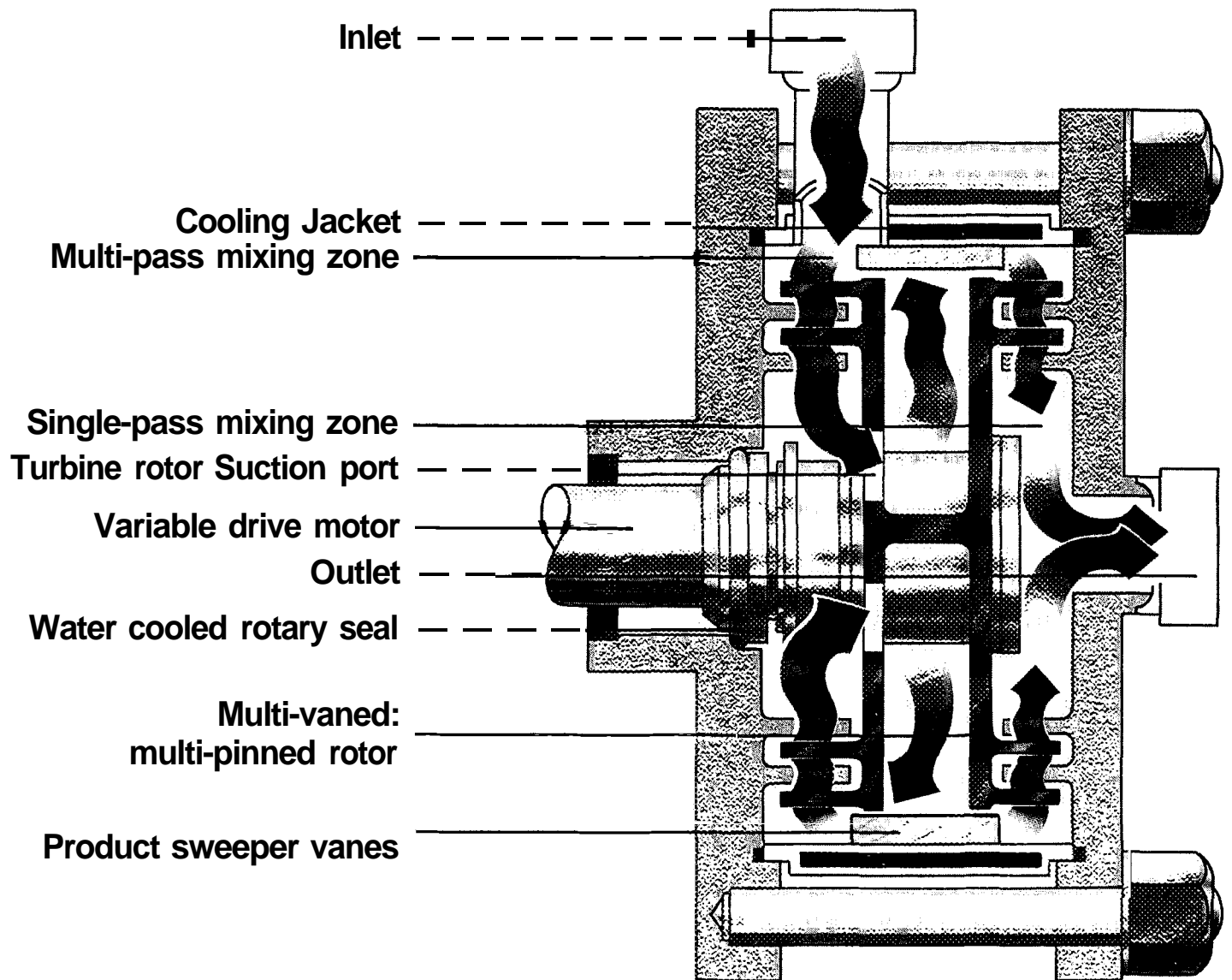

## 1. Potential Applications

The following is a partial enumeration of products and processes which are possible applications of the VOTATOR CR Mixer. These may or may not need accompanying heat transfer before or after mixing or whipping. This is not a complete list. It is a suggestive aid to help recognize similar applications.

### A. Confections

1. Marshmallow
  - a. Grain
  - b. Nongrain
  - c. Low moisture egg albumin and/or gelatin marshmallow type products.
2. Nougats
3. Aerated Chocolate
4. Fondant and Fondant Blending
5. Coloring

### B. Bakery Items

1. Marshmallow
  - a. Depositing type
  - b. Cupcake enrobing, etc.
2. Icings, frostings, fillings
3. Cake batters
4. Wafer batters
5. Preblending

### C. Other Items

1. Mayonnaise
2. Salad Dressing
3. Whipped Butter
4. Whipped Cream
5. Egg Whites
6. Etc.

### D. General

1. Emulsification
2. Homogenization
3. Pigment Dispersion
4. Foaming
5. Pre-blending
6. Suspension

## SECTION V

# Operation

### A. General

Before initial operation, equipment should be dismantled and thoroughly cleaned (See Section VII )

Satisfactory life and performance depends not only on the proper application of the equipment, but also on the proper use of the equipment by the operator. Operation above the unit's rated capacity and on other than its rated product can cause damage to the unit and adversely affect performance.

Never turn shaft with the motor unless water or product is flowing through unit and water flush is on the seal or the seal will be damaged.

### B. Operating Instructions

These instructions are general in nature and should be superseded by DAILY START AND STOP PROCEDURES written to conform to actual in-plant processing conditions.

#### 1. Start Up

- a. Turn seal water on. Generally, 1/4 to 1/2 GPM will suffice.
- b. Start product pump and adjust to desired rate.
- c. After system flow is established, start CR Mixer at minimum RPM.
- d. Apply back pressure and gas flow for aeration.
- e. Adjust variables (product pressure, mixer speed, and amount of gas, etc.) for the desired product.
- f. Divert product to usage point or container.

## 2. Shut Down

Shut down procedure is normally the reverse of start up procedure; however, before turning

power off, run speed control on drive motor to the minimum RPM setting.

## Section VI

# Disassembly and Assembly

For disassembly and assembly, refer to the appropriate drawing, Number 44928, for the 6 inch mixer and Number 402158 for the 16 inch mixer.

### A. Disassembly

1. Safety first: Disconnect the electrical or other drive source.
2. Disconnect product piping connections and seal flushing connections.
3. Remove or open front head.
4. Remove tube assembly.
5. Remove hex head capscrew in rotor shaft and retaining washer.
6. Remove turbine disc and turbine from drive shaft.
7. Remove key and seal assembly.
8. To remove the rear turbine head, remove the four bolts on the drive frame. (Not usually necessary during cleaning.)
9. Check pins for damage and seal surfaces and "O"-Rings for wear. Clean all parts before reassembly.

### B. Assembly

1. Carefully place rear turbine head, if it was removed, on motor after being sure that the seals and "O"-Rings are in place.

#### NOTE

Lubricate all "O"-Rings before installation.

2. Secure head.

3. Check seal insert for correct installation.
4. (a) 6 inch mixer - place fiberglass gasket on shaft and install seal assembly with "O"-Ring, carefully placing seal body against the seal ring followed by the spring and then the sleeve.

#### NOTE

Be sure that drive pin on sleeve (Number 23952-B) is lined up with the slot in the seal body (Number 18747-G).

- (b) 16 inch mixer - place seal body with "O"-Ring against seal insert, carefully lining up the slot with the pin on the drive shaft. Install seal backing ring followed by the wavy washers.

5. Install key.
6. Install turbine and turbine internal head
7. Install retaining washer and lock bolt in drive shaft. Be sure both "O"-Rings are in the retaining washer.
8. Check for proper installation of "O"-Rings on the front and rear heads. Install tube placing the sanitary inlet connection over the sanitary pins on the rear turbine head.
9. Close or install front head and tighten the appropriate bolts.
10. Connect product piping and seal flushing.
11. Connect electrical or other drive source.

## SECTION VII

# Care of Votator CR Mixer

### A. Cleaning and Sanitizing

Please do not construe the following as anything but SUGGESTIONS, RECOMMENDATIONS, and GUIDES regarding the CLEANING and SANITIZING of all types of VOTATOR EQUIPMENT used in the food industry.

The cleaning procedure should comply with the existing sanitation codes. In addition, it should be designed for a specific product and process.

Prior to determining a daily cleaning procedure and the detergent, it must be stated and understood that:

1. Areas such as "O"-Ring grooves, capillary clearances between running parts, etc., are best cleaned by disassembly and manual scrubbing.
2. The cleaning procedure and the detergent efficiency depend on the following factors:
  - a. Time allotted for cleaning solutions to do the job.

b. Temperature of cleaning solutions while doing the job.

c. Detergent Concentration and Composition: This is dictated by nature of the soil to be removed and the surface from which the soil must be removed. In short, the detergent or detergents must remove the soil without impairing the equipment.

d. Water Composition: This is one item frequently overlooked. Good clean, potable water alone does not always suffice. The mineral content of the cleaning water must be such that it does not detract from the detergent's effectiveness. For example, water containing large amounts of iron, maganese and certain other metals may produce a brown deposit and weaken the detergent strength. Ideally, the water should be soft or softened.

## SECTION VIII

# General Maintenance

### A. Rotary Seals

#### 1. Seal Body and Seal Insert

These are the most pertinent portions of all rotary seals. LEAKLESS operation results because and when:

- a. The running surfaces are precision lapped and polished.
- b. The running surfaces are absolutely flat.

c. The running surfaces are held absolutely parallel.

d. The mechanical pressure holding the running surfaces together is sufficient but not excessive.

The following are the most prevalent causes and remedies for product leaking between these two smooth, flat faces.

# Troubleshooting

## CAUSE

Seal Body and/or Seal Faces worn or damaged

Seal Insert cocked when installed

Seal Insert cracked

Seal Insert face and shoulder worn

Seal Springs weakened

Seal Backing Ring deformed

Seal Body freedom diminished or stopped due to unclean shaft, seal body "O"-Ring recess, seal backing ring, or faulty seal body "O"-Ring

Seal Body and Seal Insert mismatched

Seal Drive Pin worn or missing

Insufficient spring pressure to hold Body and Insert together after several hours of a daily run.

Seal Body and/or Seal Insert damaged by rough handling.

New or repaired Seal Body installed against worn or damaged seal Insert and vice versa

Excessive wear of Seal Body and/or Seal Insert

## REMEDY

Replace. Contact VOTATOR DIVISION for repairing feasibility.

Remove and reinstall making sure insert o-ring is not twisted. See Insert o-ring below.

Replace.

Replace with new seal insert.

Rebend or replace.

Replace with new Backing Ring.

Disassemble, clean, inspect, lubricate pieces and reassemble. (See Seal Body o-ring below).

Always replace seal body against the seal insert it has been running with until new parts replacement is necessary.

Replace with new seal driving pin.

Reform or replace weakened springs. For adding additional springs contact VOTATOR DIVISION.

Always lay seal faces on clean, soft cloth. Move impeller into position gently. DO NOT slam it "home."

One good seal face against a worn or damaged face **will not work.**

Do not operate rotor without product, water, or detergent flow. **These are not gas seals.** They operate on liquids only.

Excessive spring pressure.

## 2. Seal Insert **O-Ring**

### **CAUSE**

Twisted when installed  
Wrong size, distorted, deformed or cut  
Wrong o-ring compound

### **REMEDY**

Lubricate before installing. (Suitable Lubricant)  
Replace with new o-ring.  
Replace with specified o-ring

## 3. Seal Body **O-Ring**

### **CAUSE**

Twisted when installed  
Wrong o-ring compound  
Wrong size, distorted, deformed or cut  
Damaged Seal Body  
Damaged Seal Backing Ring  
Damage on shaft at o-ring sealing area  
Obstruction on shaft stub (uncleaned shaft)

### **REMEDY**

Lubricate before installing  
Replace with specified o-ring  
Replace with new o-ring  
Replace Seal Body  
Replace Seal Backing Ring  
Contact VOTATOR DIVISION about repairs.  
Remove obstruction, clean and lubricate shaft prior to seal body installation

## **B Spare Parts**

A recommended spare parts list is included with the equipment drawings. Much down time can be eliminated if the suggested parts are stocked for ready installation in case of difficulties

2. The ANCO/VOTATOR DIVISION can furnish all Votator manufactured items and purchased components to assemble this equipment Individual repair parts of purchased components are not stocked by the Votator Division When these are needed, order directly from the manufacturer for quicker delivery at a lower cost.

3. Direct all inquiries and orders for replacement parts to.

Waukesha Cherry-Burrell  
611 Sugar Creek Road  
Delavan, WI 53115 USA  
Tel 800.252.5200 or 262.728.1900  
Fax 800.252.5012 or 262.728.4904  
E-mail info@processequipment.spx.com

Give a complete description and number of each part Always include the serial number of the unit stamped on the name plate.

## **Waukesha Cherry-Burrell Warranty**

Seller warrants its products to be free from defect in materials and workmanship for a period of one (1) year from the date of shipment. This warranty shall not apply to products which require repair or replacement due to normal wear and tear or to products which are subjected to accident, misuse or improper maintenance. This warranty extends only to the original Buyer. Products manufactured by others but furnished by Seller are exempted from this warranty and are limited to the original manufacturer's warranty.

Seller's sole obligation under this warranty shall be to repair or replace any products that Seller determines, in its discretion, to be defective. Seller reserves the right either to inspect the products in the field or to request their prepaid return to Seller. Seller shall not be responsible for any transportation charges, duty, taxes, freight, labor or other costs. The cost of removing and/or installing products which have been repaired or replaced shall be at Buyer's expense.

Seller expressly disclaims all other warranties, express or implied, including without limitation any warranty of merchantability of fitness for a particular purpose. The foregoing sets forth Seller's entire and exclusive liability, and Buyer's exclusive and sole remedy, for any claim of damages in connection with the sale of products. In no event shall Seller be liable for any special consequential incidental or indirect damages (including without limitation attorney's fees and expenses), nor shall Seller be liable for any loss of profit or material arising out of or relating to the sale or operation of the products based on contract, tort (including negligence), strict liability or otherwise.

### **Shipping Damage or Loss**

If equipment is damaged or lost in transit, file a claim at once with the delivering carrier. The carrier has signed the Bill of Lading acknowledging that the shipment has been received from WCB in good condition. WCB is not responsible for the collection of claims or replacement of materials due to transit shortages or damages.

### **Warranty Claim**

Warranty claims must have a **Returned Goods Authorization (RGA)** from the Seller before returns will be accepted.

Claims for shortages or other errors, exclusive of transit shortages or damages, must be made in writing to Seller within ten (10) days after delivery. Failure to give such notice shall constitute acceptance and waiver of all such claims by Buyer.

## Safety

### READ AND UNDERSTAND THIS MANUAL PRIOR TO INSTALLING, OPERATING OR SERVICING THIS EQUIPMENT

Waukesha Cherry-Burrell recommends users of our equipment and designs follow the latest Industrial Safety Standards. At a minimum, these should include the industrial safety requirements established by:

1. Occupational Safety and Health Administration (OSHA), Title 29 of the CFR  
Section 1910.212- General Requirements for all Machines
2. National Fire Protection Association, ANSI/NFPA 79  
ANSI/NFPA 79- Electrical Standards for Industrial Machinery
3. National Electrical Code, ANSI/NFPA 70  
ANSI/NFPA 70- National Electrical Code  
ANSI/NFPA 70E- Electrical Safety Requirement for Employee Workplaces
4. American National Standards Institute, Section B11

**Attention:** Servicing energized industrial equipment can be hazardous. Severe injury or death can result from electrical shock, burn, or unintended actuation of controlled equipment. Recommended practice is to disconnect and lockout industrial equipment from power sources, and release stored energy, if present. Refer to the National Fire Protection Association Standard No. NFPA70E, Part II and (as applicable) OSHA rules for Control of Hazardous Energy Sources (Lockout-Tagout) and OSHA Electrical Safety Related Work Practices, including procedural requirements for:

- Lockout-tagout
- Personnel qualifications and training requirements
- When it is not feasible to de-energize and lockout-tagout electrical circuits and equipment before working on or near exposed circuit parts

**Locking and Interlocking Devices:** These devices should be checked for proper working condition and capability of performing their intended functions. Make replacements only with the original manufacturer's renewal parts or kits. Adjust or repair in accordance with the manufacturer's instructions.

**Periodic Inspection:** Industrial equipment should be inspected periodically. Inspection intervals should be based on environmental and operating conditions and adjusted as indicated by experience. At a minimum, an initial inspection within 3 to 4 months after installation is recommended. Inspection of the electrical control systems should meet the recommendations as specified in the National Electrical Manufacturers Association (NEMA) Standard No. ICS 1.3, Preventative Maintenance of Industrial Control and Systems Equipment, for the general guidelines for setting-up a periodic maintenance program.

**Replacement Equipment:** Use only replacement parts and devices recommended by the manufacturer to maintain the integrity of the equipment. Make sure the parts are properly matched to the equipment series, model, serial number, and revision level of the equipment.

Warnings and cautions are provided in this manual to help avoid serious injury and/or possible damage to equipment:



**DANGER:** marked with a stop sign.  
Immediate hazards which **WILL** result in severe personal injury or death.



**WARNING:** marked with a warning triangle.  
Hazards or unsafe practices which **COULD** result in severe personal injury or death.



**CAUTION:** marked with a warning triangle.  
Hazards or unsafe practices which **COULD** result in minor personal injury or product or property damage.

## Care of Stainless Steel

### Stainless Steel Corrosion

The austenitic stainless steel components in Waukesha Cherry-Burrell equipment are machined, welded and assembled by skilled craftsmen using manufacturing methods to preserve the corrosion resistant quality of the stainless steel.



**CAUTION:** Highly corrosive acids, such as hydrofluoric, hydrochloric and sulfuric, are not recommended as acidic cleaners for austenitic stainless steel. Phosphoric and citric acid-based cleaners at low concentrations (0.5 - 1.5% w/w) and temperature (phosphoric < 115°F (45°C) and citric < 160°F (70°C)) can be used in specific applications, as recommended by reputable chemical manufacturers. Acidic cleaners should contain corrosion inhibitors to reduce the corrosive effects on the metal.

Corrosion resistance of austenitic stainless steel is greatest when a layer of oxidation is formed on the surface of the metal. If the protective surface is disturbed or destroyed, the metal easily can be corroded by contact fluids.

1. Regularly inspect austenitic stainless steel equipment for surface deposition and/or localized **pitting corrosion**. If deposition or discoloration is detected, disassemble equipment, remove components and soak in a mild alkaline-based detergent. Rinse using warm water. Allow equipment to air dry thoroughly before assembly.
2. Regularly check all electrical devices and verify all equipment is grounded to avoid any **electrolytic-concentration corrosion**.
3. Regularly inspect joints and gaskets in the system for **crevice corrosion**.
4. Regularly inspect equipment for trapped air pockets to avoid pitting caused by **oxygen-concentration corrosion**.
5. Regularly inspect any areas of equipment using dissimilar metals connected by a mechanical joint to avoid **galvanic corrosion**.
6. Regularly inspect system components not manufactured with stabilized low carbon stainless steel (**intergranular corrosion**).
7. Regularly inspect equipment for implied stresses from either mechanical or chemical environments to avoid **stress corrosion cracking**. Chloride stress corrosion cracking of austenitic stainless steel is caused by the presence of chlorides on the surface of the metal, inducing cracks and fatiguing the metal. The use of chemicals or fluids containing chlorides should be avoided.

**Cleaning Stainless Steel**

Cleaning of austenitic stainless steel (AISI 300 Series), manually or chemically, is dependant on the process environment the equipment is operated in. Typically, the cleaning regimen should be developed and reviewed by a plant sanitarian or a formulation representative of a reputable chemical supply company. The following chemicals may be utilized to clean, passivate and disinfect equipment prior to operation.

- **Alkaline Detergent:** A blended alkaline detergent may be used to clean equipment. The detergent should be a blended sodium hydroxide/water detergent, designed for use with austenitic stainless steel equipment and used at initial concentrations of 1-3% w/w solution at a temperature of 160°F (70°C) to 195°F (90°C) (dependant on the chemical supplier). The detergent should be formulated with a metal chelation agent, such as sodium gluconate or gluconic acid, to remove metal ions in the water (hardness dependant) and a surfactant to increase the rinse ability of the solution.
- **Acid:** To neutralize any residual alkali and render a passive surface on the stainless steel, a 160°F (70°C) solution of citric acid and water at a concentration of 0.5-3% w/w can be used. Phosphoric acid may be used at concentrations of 0.5-1.5% w/w at 115°F (45°C). If phosphoric acid is used, corrosion inhibitors should be blended in prior to use.
- **Disinfectant (Food Plants):** Caution should be used with application of chemical disinfectants. Most chemical disinfectants are halogen- or quarternary ammonium-based compounds and, in high concentrations, are very corrosive to austenitic stainless steel. Typically, the most common disinfectant, iodophor, can be used with a maximum concentration of 25 mg/l at a maximum temperature of < 80°F (25°C). Other common disinfectants, such as sodium hypochlorite and chloroamine, are not recommended.

**Suggested Cleaning Regimen**

1. Cold water prerinse 60°F - 80°F (15°C - 25°C)
2. Warm water prerinse 115°F - 140°F (45°C - 60°C)
3. Alkali recirculation 160°F - 195°F (70°C - 90°C)
4. Warm water postrinse 115°F - 140°F (45°C - 60°C)
5. Acid recirculation 80°F - 115°F (25°C - 45°C)
6. Warm water postrinse 115°F - 140°F (45°C - 60°C)

**Suggested Passivation Regimen**

1. Cold water prerinse 60°F - 80°F (15°C - 25°C)
2. Warm water prerinse 115°F - 140°F (45°C - 60°C)
3. Citric acid recirculation 140°F - 160°F (60°C - 70°C)
4. Warm water postrinse 115°F - 140°F (45°C - 60°C)
5. Cold water postrinse 60°F - 80°F (15°C - 25°C)

For manual cleaning, use only soft, non-metallic brushes, sponges or pads. Brush with the grain on polished surfaces. Avoid scratching.

Parts Lists

6" Votator CR Mixer

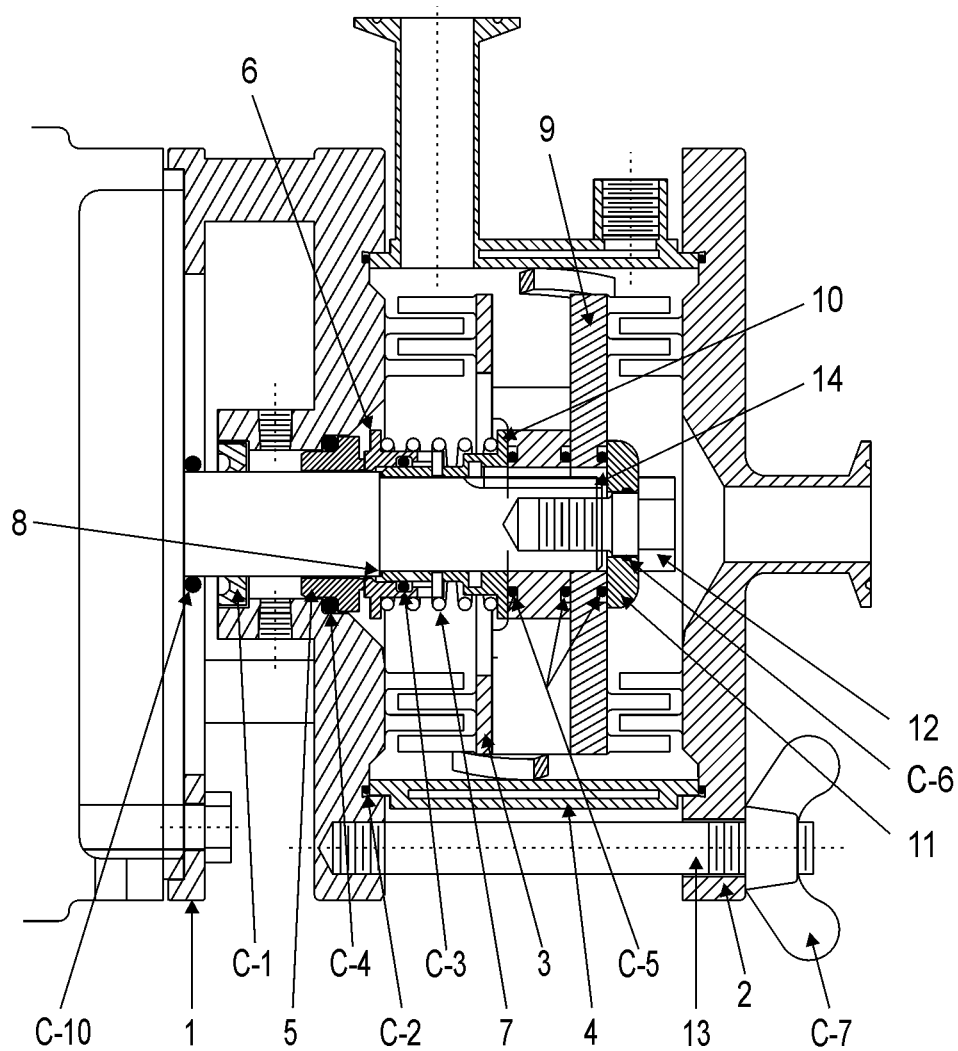

DP100-006

**6" Votator CR Mixer**

ITEM #	DESCRIPTION	QTY	PART #
C01	Shaft Seal	1	700030A87
C02	O-ring-164 FDA Nitrile/Buna FDA EPDM FDA FKM	2	N70164
			E70164
			V70164
C03	O-ring-220 FDA Nitrile/Buna FDA EPDM FDA FKM	1	N70220
			E70220
			V70220
C04	O-ring-327 FDA Nitrile/Buna FDA EPDM FDA FKM	1	N70327
			E70327
			V70327
C05	O-ring-222 FDA Nitrile/Buna FDA EPDM FDA FKM	3	N70222
			E70222
			V70222
C06	O-ring-018 FDA Nitrile/Buna FDA EPDM FDA FKM	1	N70018
			E70018
			V70018
C07	Wing Nut	4	710293
C10	O-ring-216 Buna (slinger ring) EPDM (slinger ring)	1	N70216
			E70216
1	Turbine Head	1	LL44927B
2	6" CR Outlet Head, 1" S-line	1	LL34474C
3	Turbine	1	LL34475B
4	CR Mixer Tube, 1" S-line no jacket with jacket	1	LL34477D
			LL34477F01
5	Seal Ring carbon ceramic	1	LL18717A1
			LL18717C1
6	Seal Body tungsten carbide faced aluminum oxide faced	1	LL18747H
			LL18747G
7	Spring	1	117729
8	Gasket	1	LL113220
9	Turbine Disc	1	LL34476B
10	Sleeve	1	LL23952B
11	Retaining Washer	1	113805B
12	Lock Bolt	1	113806B
13	Special Stud	4	112270A33
14	Key 1/4" x 1/4" x 1-1/2" (supplied with motor)	1	-
15	Non-code Nameplate	1	LL19566

DP 100-010a

**16" Votator CR Mixer**

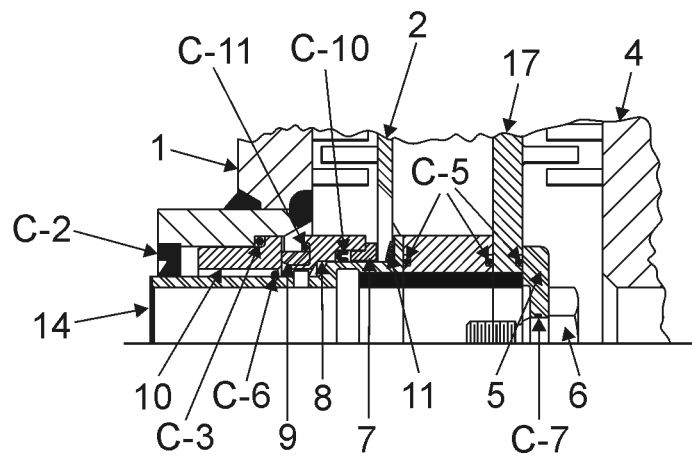
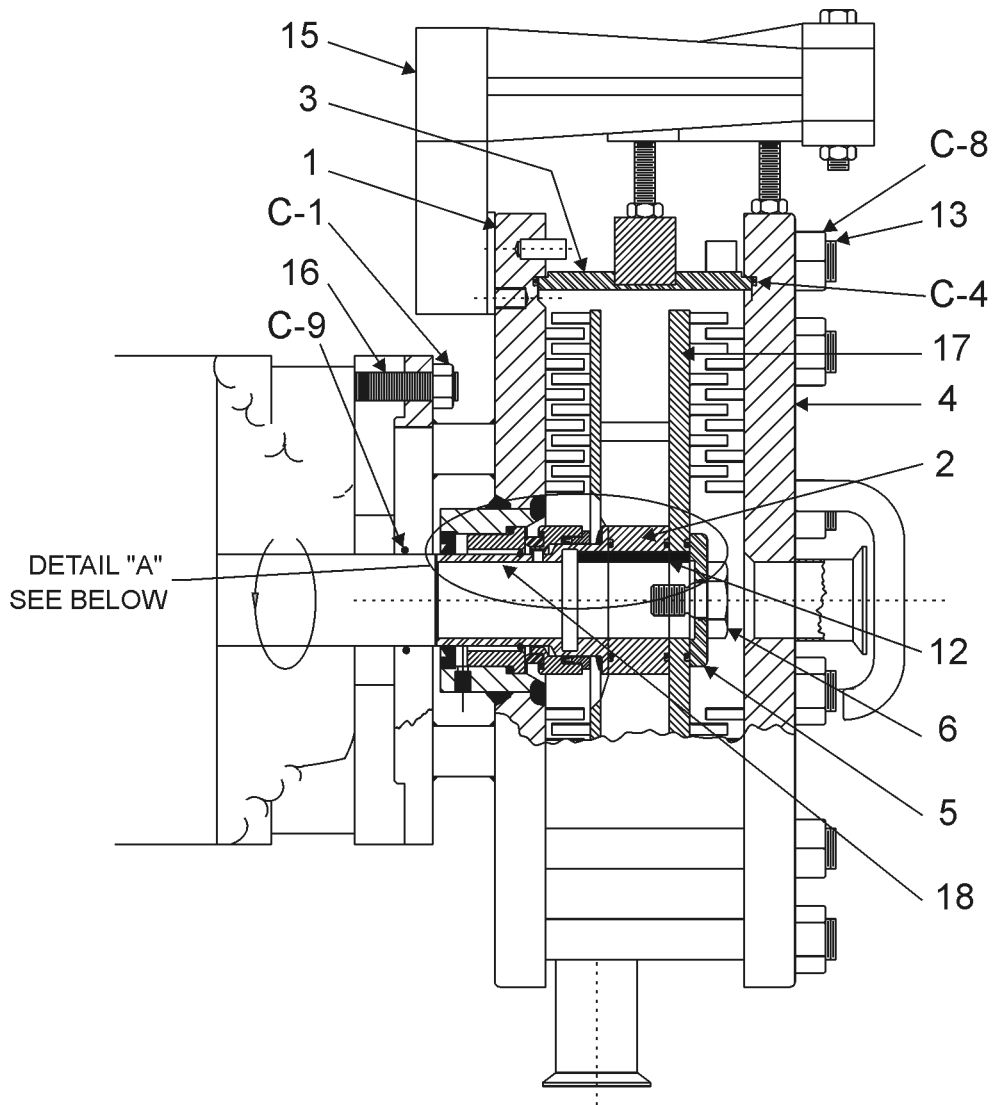

DETAIL "A"

DP100-007

**16" Votator CR Mixer**

ITEM #	DESCRIPTION	QTY	PART #
C01	Hexagon Nut	4	712585
C02	Shaft Seal, Nitrile/Buna	1	700030A42
C03	O-ring-339 FDA Nitrile/Buna FDA EPDM FDA FKM	1	N70339
			E70339
			V70339
C04	O-ring-281 FDA Nitrile/Buna FDA EPDM FDA FKM	2	N70281
			E70281
			V70281
C05	O-ring-231 FDA Nitrile/Buna FDA EPDM FDA FKM	3	N70231
			E70231
			V70231
C06	O-ring-226 FDA Nitrile/Buna FDA EPDM FDA FKM	1	N70226
			E70226
			V70226
C07	O-ring-020 FDA Nitrile/Buna FDA EPDM FDA FKM	1	N70020
			E70020
			V70020
C08	Hexagon Nut	12	300563
C09	O-ring-228 SBR (slinger ring)	1	N70228
C10	U-Cup FDA Nitrile/Buna FDA EPDM FDA FKM	1	700014A05
			700014A03
			700014A08
C11	O-ring-235 FDA Nitrile/Buna FDA EPDM FDA FKM	1	N70235
			E70235
			V70235
C12	Drive Screw	8	920295

ITEM #	DESCRIPTION	QTY	PART #
1	Drive End Turbine	1	401802C
2	Turbine Hub	1	LL44917A
3	CR Mixer Tube, 2"S-line no jacket with jacket	1	404218
			402153B04
4	Opposite Drive End Turbine Head,	1	402154D
5	Retaining Washer	1	113794A
6	Lock Bolt	1	113795A
7	Seal Backup Ring	1	110203C1
8	Seal Body	1	110893A
9	Seal Body Insert carbon ceramic	1	110892A5
			110892C1
10	Seal Head Insert ceramic tungsten carbide	1	110891A
			110891C
11	Wavy Washer	2	LL19625A
12	Key 1/4"x 1/4" x 2-1/2"	1	LL102191
13	Special Stud	12	112270A35
14	Gasket	1	113300
15	Hinge Link Assembly	1	402157
16	Special Stud	4	112270A34
17	Turbine Plate	1	LL44918A
18	Mixer Sleeve	1	301802B
19	Logo Nameplate (not shown)	1	123710
20	Non-code Nameplate (not shown)	1	LL19566

DP 100-010b