

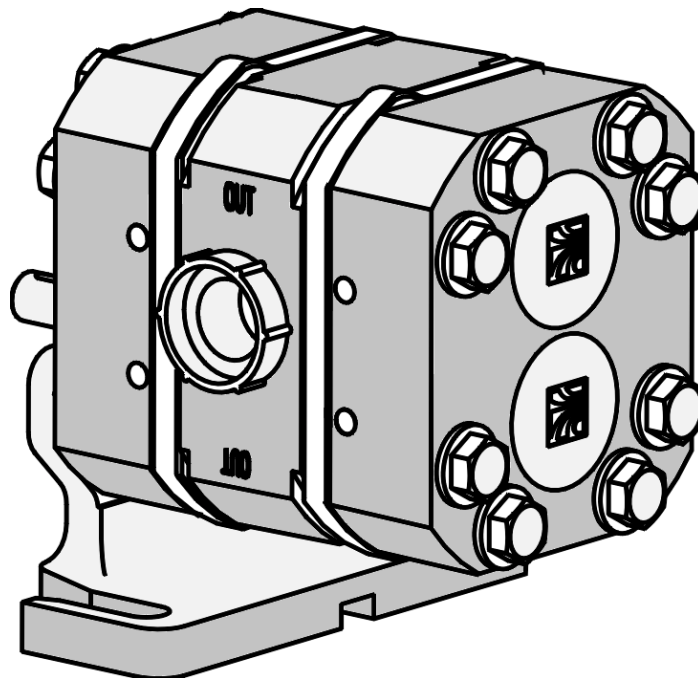

Read and understand this manual prior to installing, operating or maintaining this pump.



EFFECTIVE DATE:
OCTOBER 19, 1998

**WAUKESHA CHERRY-BURRELL
UNIVERSAL UG SERIES
GEAR PUMPS**

**SPECIFICATIONS
INSTALLATION
& PARTS LIST**

SAFETY

Warnings, cautions and notes are contained in this manual. To avoid serious injury and/or possible damage to equipment, pay attention to these messages.

WARNING Hazards or unsafe practices which **COULD** result in severe personal injury or death and how to avoid it.

CAUTION Hazards or unsafe practices which **COULD** result in minor personal injury or product or property damage.

NOTE Important information pertaining directly to the subject.

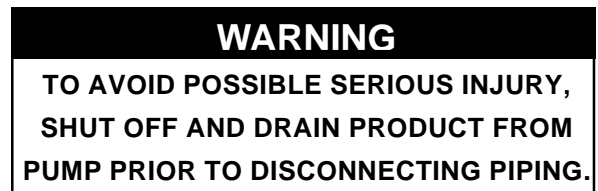

REPLACEMENT LABEL



REPLACEMENT LABEL

Read and understand this manual prior to installing, operating or maintaining this pump.

TABLE OF CONTENTS

SAFETY	3
RECEIVING AND WARRANTY	5
Factory Inspection	
Receiving inspection	
Loss or Damage	
INTRODUCTION	6
Specifications	6
INSTALLATION	7
Mounting Positions A, B, C, D	7
BASIC DIMENSIONS	
3UG	8
6UG	9
9UG	10
CUTAWAY DRAWING	11
BENCH DISASSEMBLY	12-13
COMPLETE ASSEMBLY	14-17
PARTS LIST	
MODEL 3UG GEAR PUMP	18
MODEL 6UG GEAR PUMP	19
MODEL 9UG GEAR PUMP	20
PARTS ORDERING INFORMATION	21

RECEIVING AND WARRANTY

Waukesha Cherry-Burrell Warranty

Seller warrants its products to be free from defects in materials and workmanship for a period of one (1) year from the date of shipment. This warranty shall not apply to products which require repair or replacement due to normal wear and tear or to products which are subjected to accident, misuse or improper maintenance. This warranty extends only to the original Buyer. Products manufactured by others but furnished by Seller are exempted from this warranty and are limited to the original manufacturer's warranty.

Seller's sole obligation under this warranty shall be to repair or replace any products that Seller determines, in its discretion, to be defective. Seller reserves the right either to inspect the products in the field or to request their prepaid return to Seller. Seller shall not be responsible for any transportation charges, duty, taxes, freight, labor or other costs. The cost of removing and/or installing products which have been repaired or replaced shall be at Buyer's expense.

Seller expressly disclaims all other warranties, express or implied, including without limitation any warranty of merchantability of fitness for a particular purpose. The foregoing sets forth Seller's entire and exclusive liability, and Buyer's exclusive and sole remedy, for any claim of damages in connection with the sale of products. In no event shall Seller be liable for any special consequential incidental or indirect damages (including without limitation attorneys' fees and expenses), nor shall Seller be liable for any loss of profit or material arising out of or relating to the sale or operation of the products based on contract, tort (including negligence), strict liability or otherwise.

FACTORY INSPECTION

Each WAUKESHA pump is shipped completely assembled, lubricated and ready for use.

The WAUKESHA pump is a precision product, designed to provide long, trouble-free service in a properly designed system with normal maintenance.

RECEIVING INSPECTION

Ports have plastic plugs installed at the factory to keep out foreign objects. If plugs are missing or damaged, a thorough inspection of fluid head is recommended. Be sure fluid head is clean and free of foreign material before rotating shaft.

LOSS OR DAMAGE

If your pump has been lost or damaged in transit, file a claim at once with the delivering carrier and ask for an Inspector to call. The carrier has signed the Bill of Lading acknowledging that the shipment has been received from us in good condition.

We will of course assist you in every way in collecting claims for loss, or damage, however, we are not responsible for the collection of claims or replacement of material.

WARRANTY

Please read the Warranty statement to correctly determine if you have a claim. In warranty claims you must have a "Returned Goods Authorization" (RGA) from the manufacturer before any returns will be accepted. Your Distributor will help you in a warranty problem. (See back pages for Information required)

INTRODUCTION

The Waukesha Cherry-Burrell UG Gear Pumps are external gear pumps designed for good metering accuracy and easy cleaning.

Accuracy is provided by the high precision of the body, front and rear covers, and the gears.

To enhance cleanability, mechanical seals are incorporated into both faces of the gears minimizing product in the pump and eliminating product from the drive keys and shaft area.

To further enhance performance, the body/front cover is ported for a **specific flow direction**.

Complete flexibility in drive shaft position and flow direction is provided by varying the location of the mounting foot and the arrangement of the pump shafts.

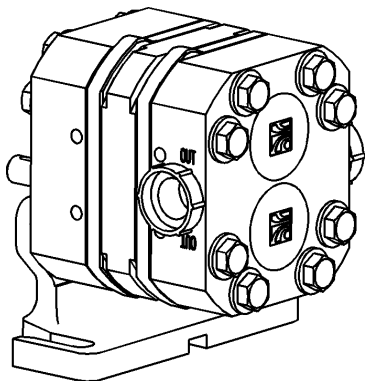

3UG

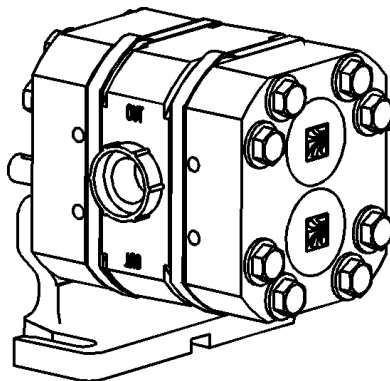

6UG

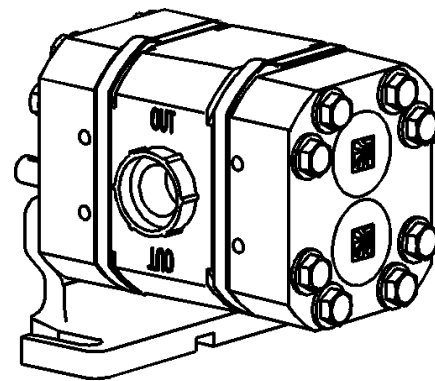

9UG

SPECIFICATIONS

- Body/Cover Material: 17-4PH Stainless Steel
- Gear Material: WM 88
- Seal/Seal Materials: Single mechanical/ceramic vs. ceramic
- Wear Plates: Ceramic
- Displacements:

Model	Displacement	Differential Pressure	Maximum Speed	Connections JI453 SAE UN	Optional S-line Connections
3UG	3.15 cc per rev.	200 psi	600 rpm	11/16-16	1/2-inch
6UG	6.30 cc per rev.	200 psi	600 rpm	13/16-16	3/4-inch
9UG	9.30 cc per rev.	150 psi	600 rpm	1-3/16-12	3/4-inch

- Ports: Marked IN and OUT
- Rotation: Pump rotation is uni-directional regardless of mounting position
- Shaft Position: Upper is standard. May be changed according to installations on Page 7

INSTALLATION

MOUNTING

There are four mounting positions that may be ordered. Position A contains has an upper drive shaft location and counterclockwise rotation (facing the liquid end of pump).

To achieve any of the other 3 positions requires moving the mounting foot, switching shaft positions or both. ***NOTE: Product flow is always to IN port and discharge from OUT port.**

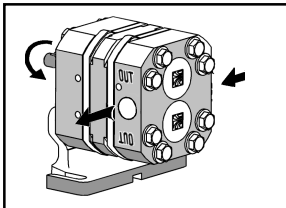

POSITION A

Upper drive shaft.
Counterclockwise upper drive shaft rotation when you face the liquid end of the pump.

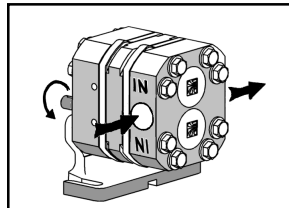

POSITION B

Lower shaft drive.
Counterclockwise drive shaft rotation.
To convert to this version from Position A, remove the mounting foot and attach it to the drive shaft end.

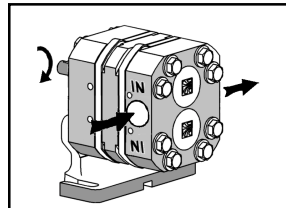

POSITION C

Upper drive shaft
Clockwise rotation of drive shaft.
To convert to this version from Position A, remove and change drive shaft and idler shaft positions on pump and attach the mounting foot to the idler end.

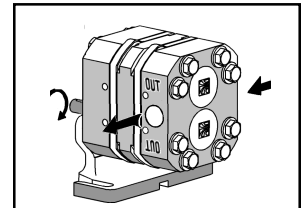

POSITION D

Lower drive shaft.
Clockwise rotation of drive shaft.
To convert to this version from Position A, remove and change drive shaft and idler shaft positions on pump.

Summary of all options

To convert to any position from any other position, follow these chart instructions.

POSITION A	CHANGE MOUNTING FOOT POSITION	POSITION B
	←————→	
POSITION A	**REMOVE AND CHANGE SHAFT POSITIONS CHANGE MOUNTING FOOT LOCATION	POSITION C
	←————→	
POSITION A	**REMOVE AND CHANGE SHAFT POSITIONS	POSITION D
	←————→	
POSITION B	**REMOVE AND CHANGE SHAFT POSITIONS	POSITION C
	←————→	
POSITION B	**REMOVE AND CHANGE SHAFT POSITIONS CHANGE MOUNTING FOOT POSITION	POSITION D
	←————→	
POSITION C	CHANGE MOUNTING FOOT POSITION	POSITION D
	←————→	

***WARNING**
REVERSING FLOW WILL
RESULT IN UNPREDICT-
ABLE PERFORMANCE
AND MAY DAMAGE
PUMP.

** SEE PAGES 12-19 FOR
DISASSEMBLY/ASSEMBLY
INSTRUCTIONS

INSTALLATION BASIC DIMENSIONS

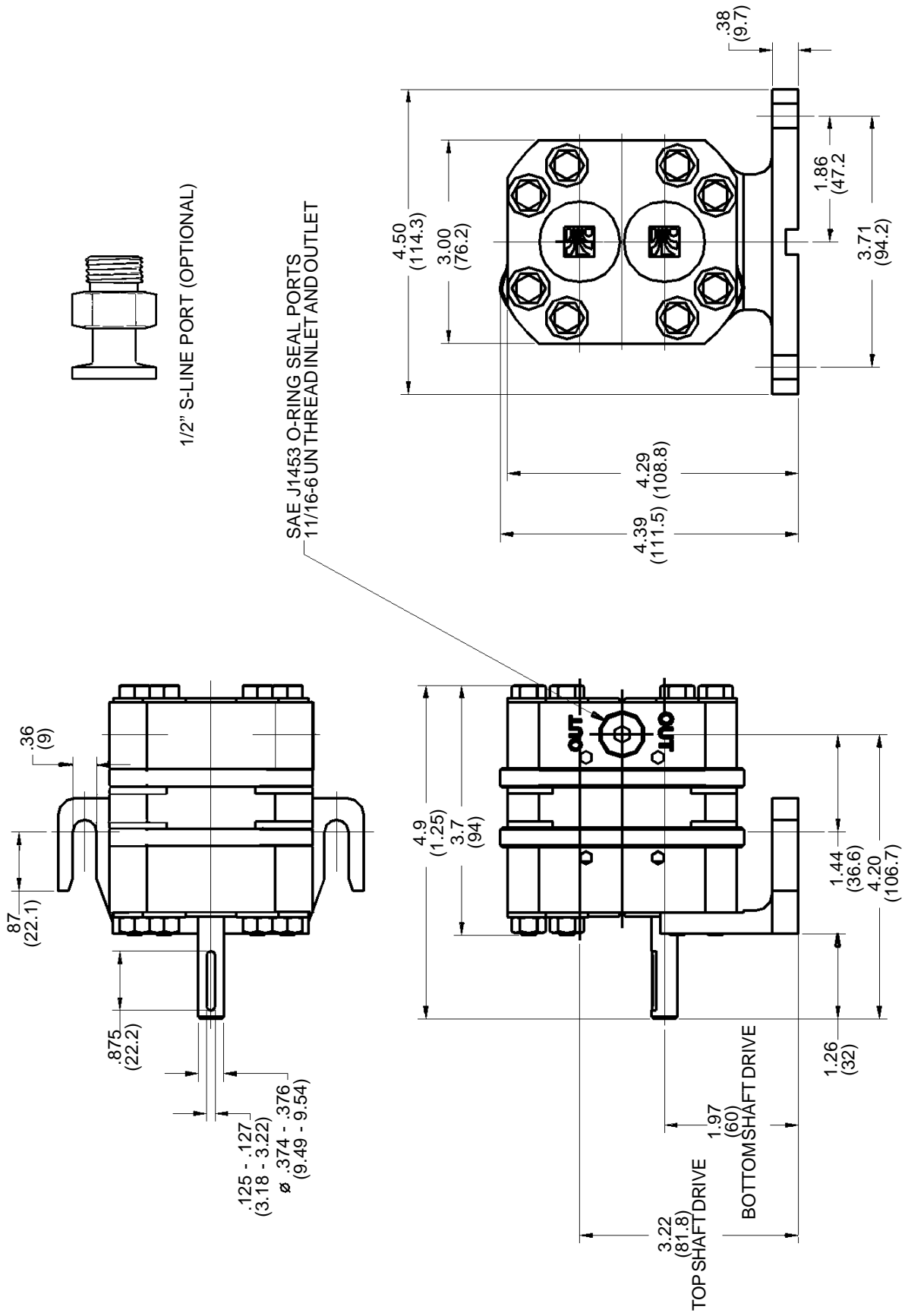

3UG GEAR PUMP BASIC DIMENSIONS

INSTALLATION BASIC DIMENSIONS

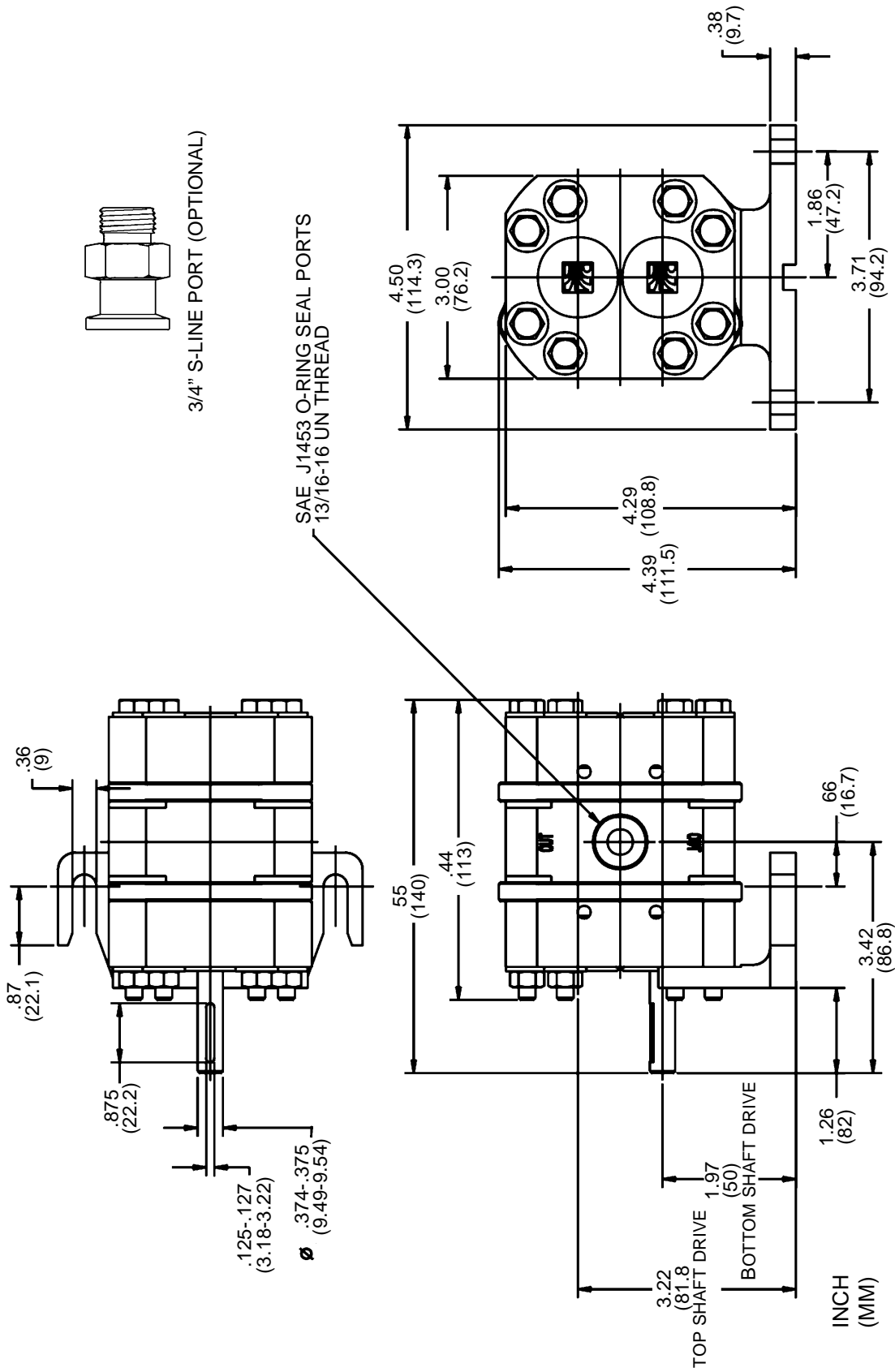

6UG GEAR PUMP BASIC DIMENSIONS

INSTALLATION BASIC DIMENSIONS

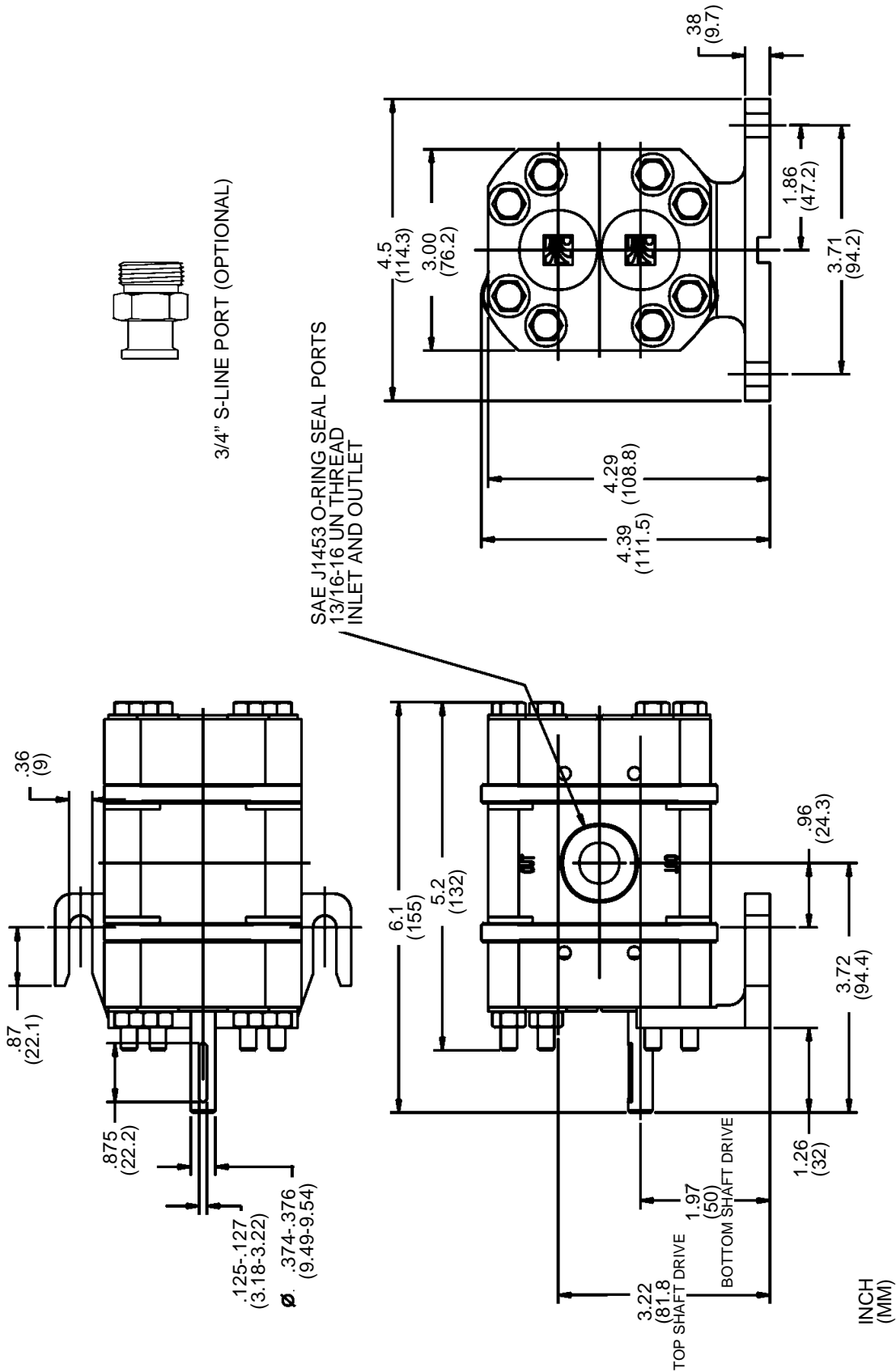

9UGWP GEAR PUMP BASIC DIMENSIONS

INSTALLATION CUTAWAY DRAWING

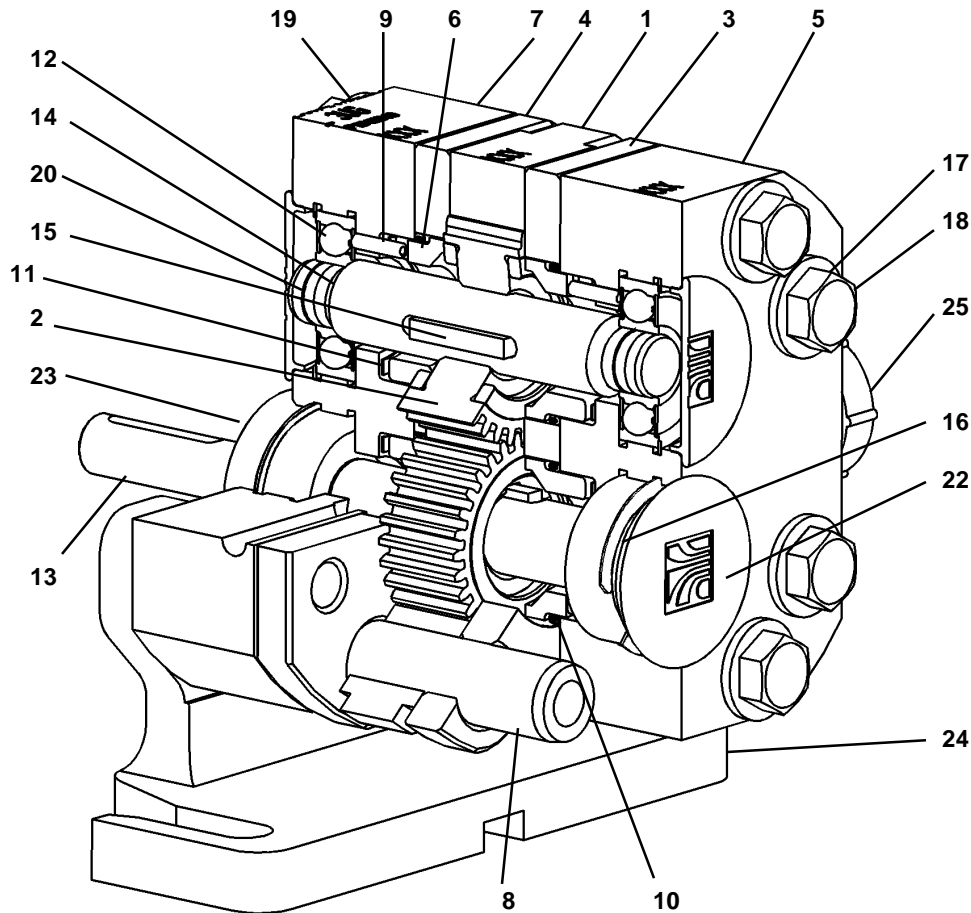

MOUNTING POSITION "D" SHOWN.
SEE PAGE 7 FOR MOUNTING POSI-
TIONS "A", "B", AND "C"

ITEM	DESCRIPTION	QTY
1	BODY	1
2	GEAR W/SEAL INSERTS	2
3	WEAR PLATE - FRONT	1
4	WEAR PLATE - REAR	1
5	COVER, FRONT	1
6	STATIONARY SEAL	4
7	COVER, REAR	1
8	DOWEL, HOLLOW	2
9	ROLL PIN	4
10	STATIONARY SEAL O-RING	4
11	WAVE SPRING	4
12	BEARING	1
13	DRIVE SHAFT	1

ITEM	DESCRIPTION	QTY
14	IDLER SHAFT	1
15	KEY, DRIVE	2
16	RETAINING RING	4
17	WASHERS	12
18	BOLTS	8
19	HEX NUT	4
20	SHAFT O-RING	4
21	*PORT O-RING (Not shown)	2
22	BEARING CAP	3
23	CAP, BEARING- DRIVE SHAFT	1
24	MOUNTING FOOT	1
25	PLASTIC PLUG	2

*MODEL 3UG ONLY

SUGGESTED BENCH DISASSEMBLY (3UG SHOWN)

(Pump is properly removed from system.)

- ① Remove four bolts and washers holding mounting foot on.
- ② Remove remaining four bolts/washers/nuts holding covers, wear plates, and body together. Remove two hollow spacers on Models 6 and 9

NOTCHES ARE PROVIDED ON CORNERS OF BODY TO ASSIST IN SEPARATING END COVERS, WEAR PLATES AND BODY, WHEN THEY ARE DIFFICULT TO SEPARATE.

SEE FIGURE ON PAGE 11

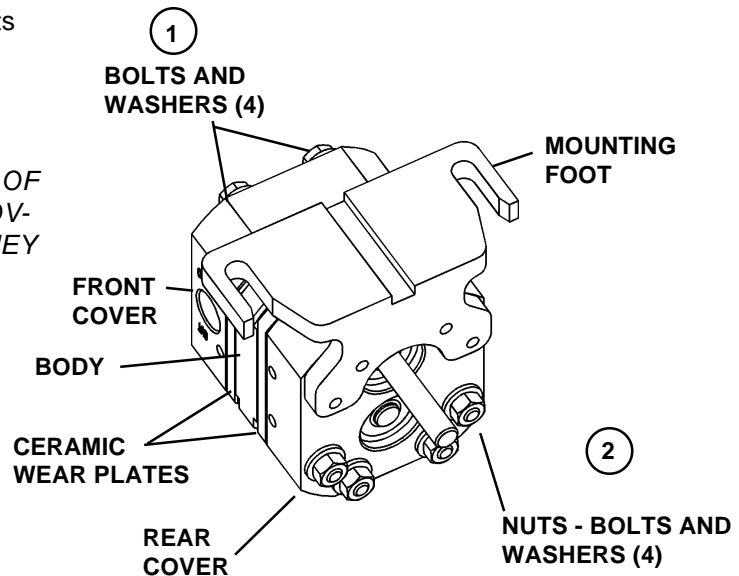

- ③ Slide front cover off two hollow dowels.
- ④ On 3UG only, remove two port O-rings from front cover.
- ⑤ * Remove front wear plate.
- ⑥ Slide out two hollow dowels
- ⑦ Remove body.
- ⑧ Remove rear wear plate.
- ⑨ Remove gears *with seal inserts*, from shafts.
- ⑩ Remove both shafts and keys from rear cover.
- ⑪ Remove four stationary seals and O-rings from the front and rear wear plates.
- ⑫ Remove eight wave springs from front and rear covers.
- ⑬ Remove and replace roll pins only if damaged.

* WEAR PLATES ARE CERAMIC. INCIDENTAL CONTACT WITH HARD OBJECTS MAY CAUSE CHIPPING, CRACKING OR BREAKING

IF BEARINGS NEED TO BE REPLACED, COMPLETE STEPS 14, 15 AND 16.

- ⑭ Remove four bearing caps from front / rear covers.
- ⑮ Remove four retaining rings from front / rear covers.
- ⑯ Press out and discard four bearings from front and rear covers.
- ⑰ Inspect the two gears with seal inserts, four stationary seals and seal O-rings, two shaft O-rings, and two port O-rings. *Replace if damaged or worn.*

NOTE: Only 3UG pump has port O-rings.

SUGGESTED BENCH DISASSEMBLY
 (3UG SHOWN)

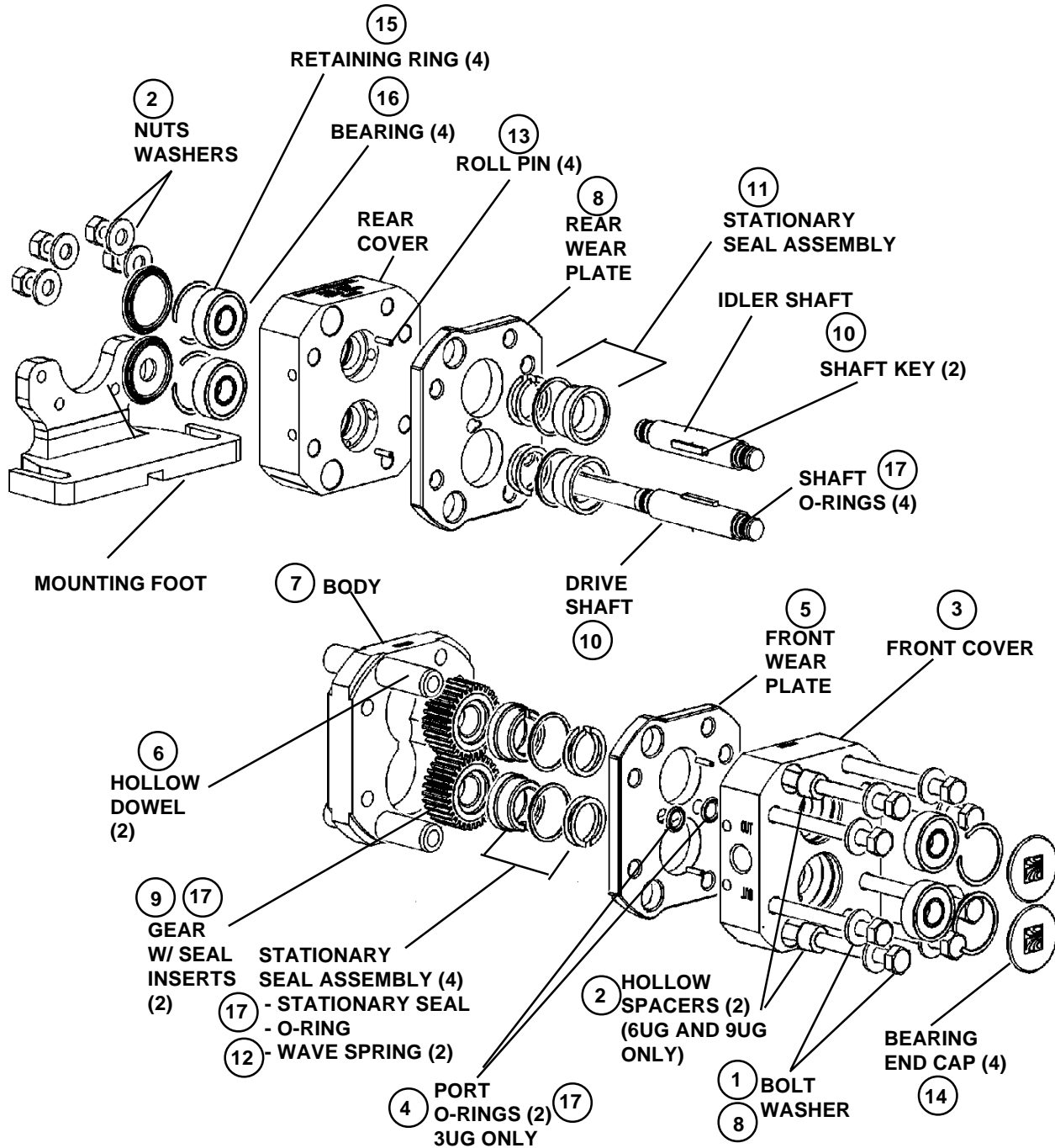

MOUNTING POSITION SHOWN IS "D"
 SEE PAGE 7 FOR MOUNTING POSITIONS
 "A", "B", AND "C"

Complete Assembly Instructions - ALL UG

NOTE: Lubricate all O-rings and shafts with silicone free lubricant.

1. Install Bearings, Retaining Rings, Roll Pins, and Bearing Caps.

- a. Press four new bearings into front and rear covers if required.
- b. Install four retaining rings and bearing caps on front and rear covers. (*One bearing cap has hole in it for drive shaft end.*)
- c. Turn front and rear covers over and install four new roll pins if required.

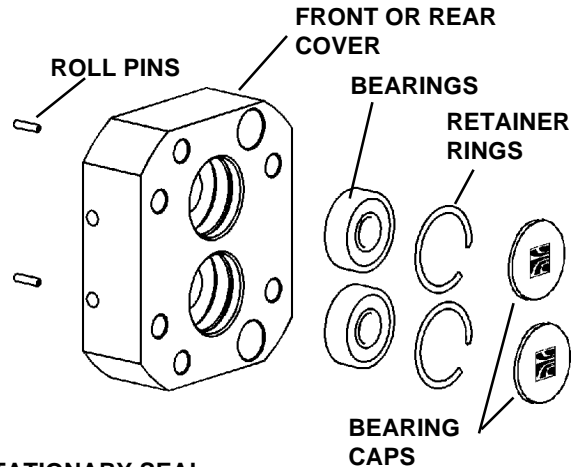

2. Install Rear Wear Plate, and Hollow Dowels.

- a. Place rear wear plate on rear cover with lapped (shiny) surface facing up.
Note: The relief channel is on the lapped side.
- b. Insert the two hollow dowels into rear wear plate and rear cover for alignment.

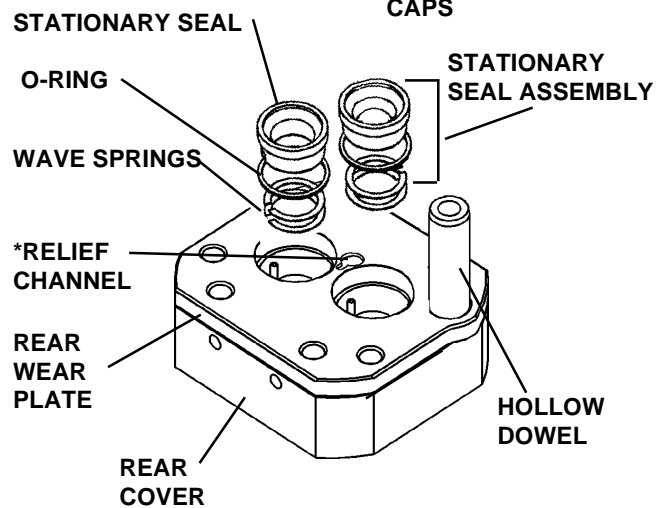

Note: Use care to avoid chipping or damage to the ceramic wear plates or seal inserts.

3. Install Wave Springs, Stationary Seals, Seal O-rings in Rear Cover and Rear Wear Plate.

- a. Install four wave springs into rear cover, with gap over roll pins.
- b. Lubricate two stationary seal O-rings with silicone free lubricant and install on stationary seals.
- c. Press seals and O-rings into rear wear plate, aligning seal notches with roll pins in rear cover. *Use WCB installation tools to assist in installing these seals and O-rings. (The sleeve has a small pilot lip that should be inserted in rear wear plate prior to pressing seal and O-ring into wear plate.)*
- d. Clean and lubricate seal faces.
- e. Remove the two hollow dowels.

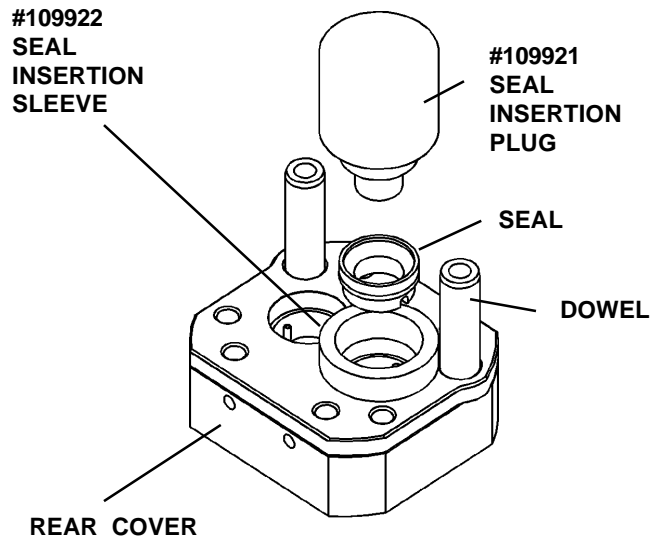

WCB has developed:
Seal Insertion Plug (P/N 109921)
Seal Insertion Sleeve (P/N 109922)
 These recommended tools must be ordered separately

Complete Assembly Instructions - (3UG shown)

NOTE: Lubricate all O-rings and shafts with silicone free lubricant.

4. Install bolts and washers

- a. Install four bolts with washers and hollow dowels thru front cover. (Dowel spacers required on 6 and 9 Models only.)
- b. Lay front cover down on four bolt heads.

5. Install Wave Springs, Stationary Seals, Seal O-rings in Front Cover and Front Wear Plate.

- a. Install four wave springs into front cover, with gap over sides of roll pins.
- b. On 3UG only, lubricate and install two port O-rings in front cover.
- c. Place front wear plate on front cover.

***Note: Lapped side (shiny surfae) faces up (toward body). Slanted port hole exits close to center of plate.**

- d. Lubricate two stationary seal O-rings with silicone free lubricant and install on stationary seals.

- e. Press seals and O-rings into front wear plate, aligning seal notches with roll pins in front cover.

Use **WCB Seal Insertion Plug (P/N 109921)** and **Seal Insertion Sleeve (P/N 109922)** to assist in installing these seals and O-rings. The sleeve has a small pilot lip that should be inserted in rear wear plate prior to pressing seal and O-ring into wear plate.)

- f. Clean and lubricate seal faces.

6. Install body

7. Install gears

Note: Gears are completely identical and may be placed either side up, keyways any position.

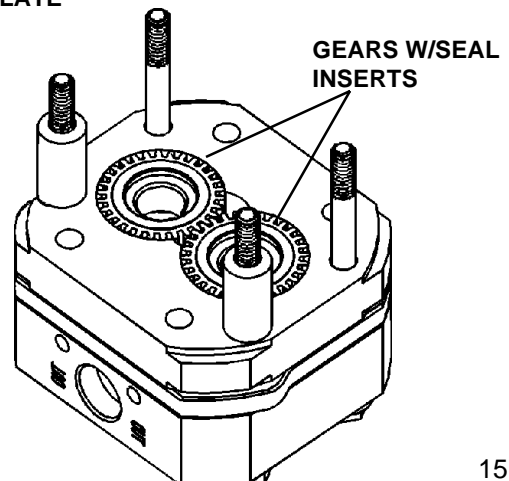
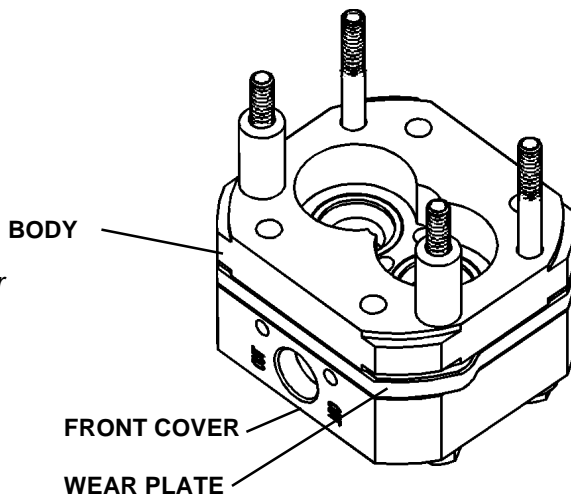
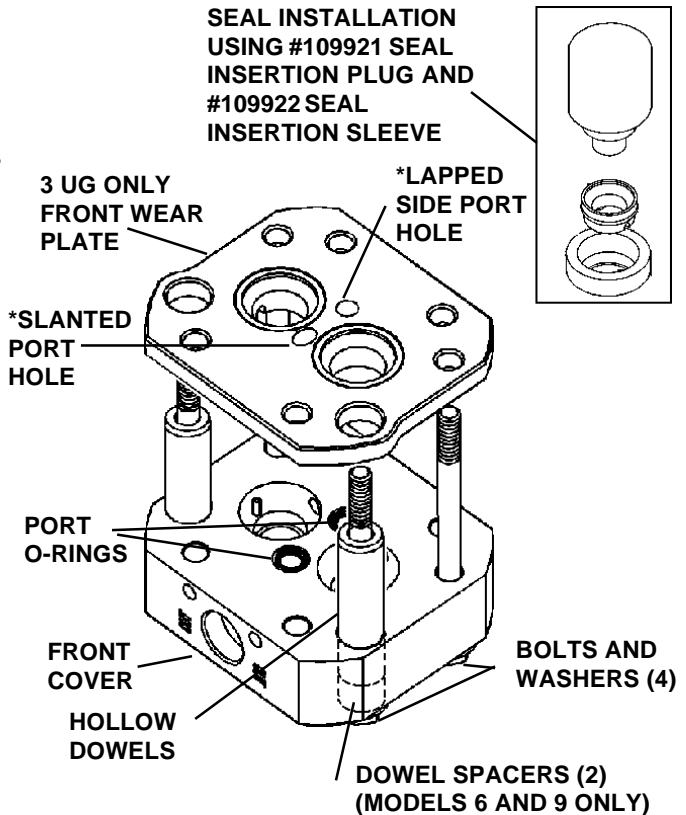

Complete Assembly Instructions All UG

8. Install shafts

a. Lubricate and install two shaft O-rings onto drive shaft.

b. Install key into drive shaft.

All lubricating must be done with approved silicone free lubricant.

c. See **Page 7** for correct orientation of drive shaft to IN and OUT ports. Lubricate drive shaft in gear area and install drive shaft into front cover, wear plate, body and gear.

d. Lubricate and install two O-rings onto idler shaft

e. Install idler shaft into front cover, wear plate, body and gear.

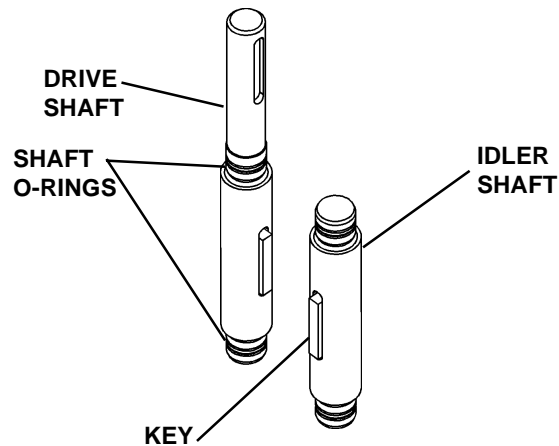

9. Install rear wear plate and rear cover.

a. Slide rear plate and rear cover assembly *from Step 3*. over shafts.

b. Install two washers and nuts onto bolts not screwed into mounting foot.

See Page 7

for correct orientation of foot to shaft to IN / OUT ports.

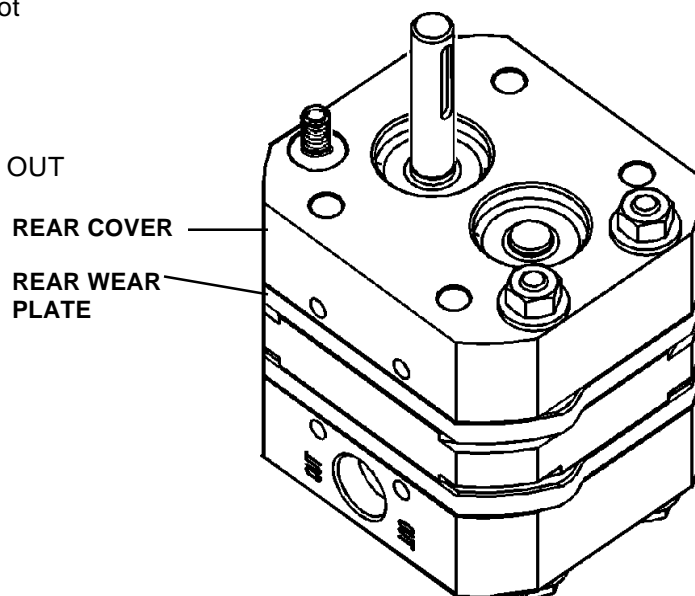
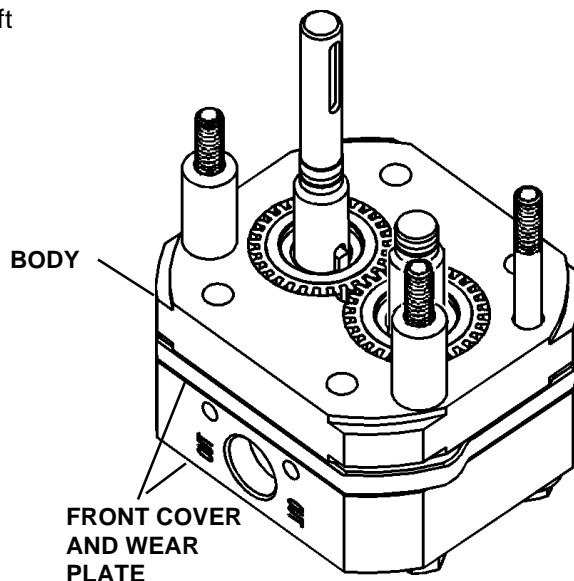

Complete Assembly Instructions 3UGWP

10. Install Mounting Foot and remaining bolts

- Place mounting foot in position, and thread in the two bolts (with washers) already in place.
- Install the remaining two bolts and washers thru covers etc. and thread into mounting foot.
- Install two remaining bolts and nuts, and four washers.

11. Torque all bolts and nuts to 75 in-lbs.

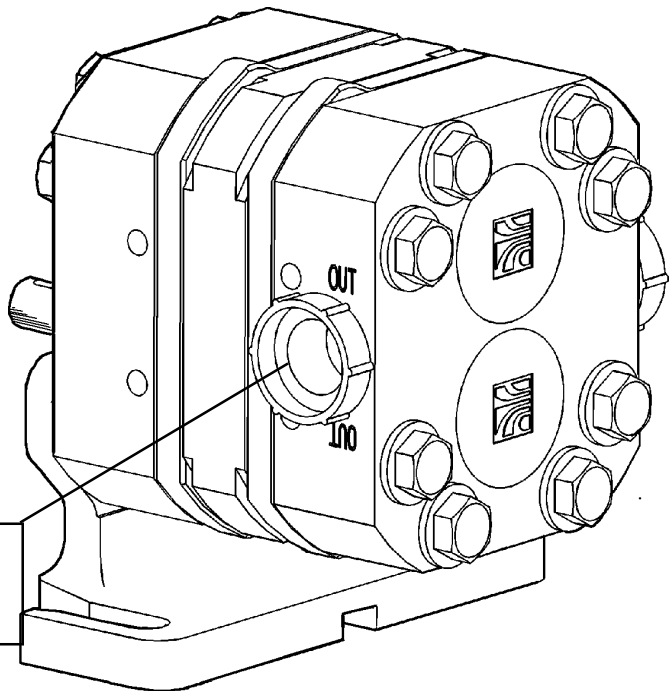
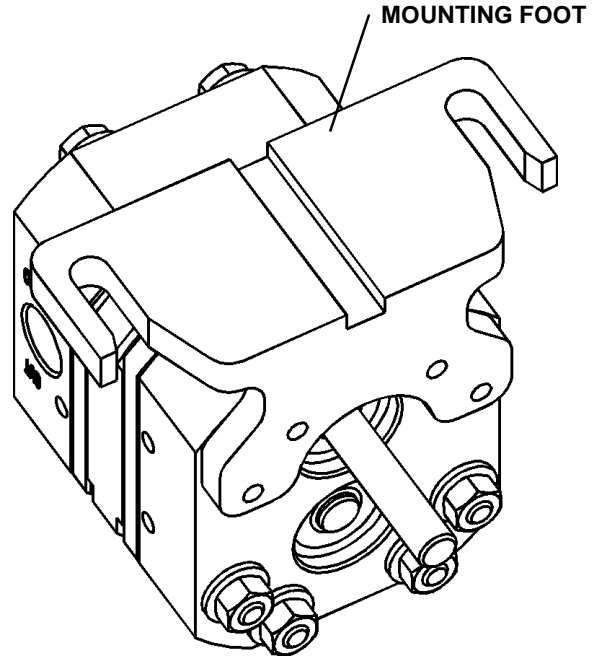

NOTE: To protect pump interior, install plastic caps in IN and OUT ports (for storage of pump or until final installation)

**FOOT SHOWN IN
POSITION "D"**

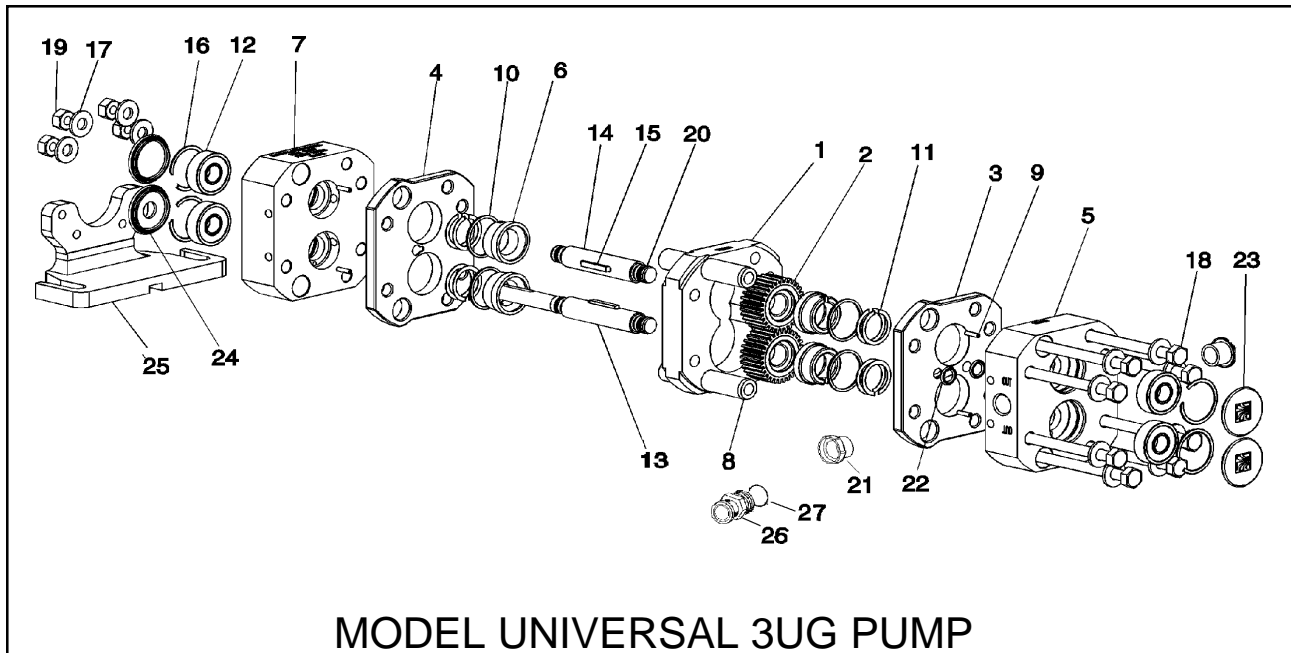

MODEL UNIVERSAL 3UG PUMP

ITEM	PART NUMBER	DESCRIPTION	QTY
1	108803	BODY	1
*2	105819	GEAR W/SEAL INSERTS	2
3	109300	WEAR PLATE - FRONT	1
4	109301	WEAR PLATE - REAR	1
5	109423	COVER, FRONT	1
*6	105812	STATIONARY SEAL	4
7	109424	COVER, REAR	1
8	105839	DOWEL, HOLLOW	2
9	30-124	ROLL PIN -	4
*10	E70020	STATIONARY SEAL O-RING EPDM	4
	V70020	STATIONARY SEAL O-RING VITON®	4
	K75020	STATIONARY SEAL O-RING KALREZ®	4
*11	105813	WAVE SPRING	8
*12	108802	BEARING	4
13	105806	SHAFT, DRIVE.	1
14	105807	SHAFT, IDLER.	1
15	107375	KEY, DRIVE.	2
16	105820	RETAINING RING.	4
17	43-27	WASHER, 1/4" PLAIN	12
18	30-591	BOLTS 1/4-20	8
19	36-53	HEX NUT, 1/4-20	4
*20	N70010	SHAFT O-RING FDA NITRILE	4
*21	107478	CAPLUG	2
*22	E70011	PORT O-RING - OIL EPDM	2
	V70011	PORT O-RING - OIL VITON®	2
	K75011	PORT O-RING - OIL KALREZ®	2
23	109425	CAP, BEARING	3
24	109426	CAP, BEARING-DRIVE SHAFT	1
25	109805	FOOT, MOUNTING	1
26	108217	S-LINE ADAPTER (OPTIONAL)	2
27		USE SAME O-RINGS AS LISTED IN ITEM 22 (OPTIONAL)	2

* RECOMMENDED SPARE PARTS

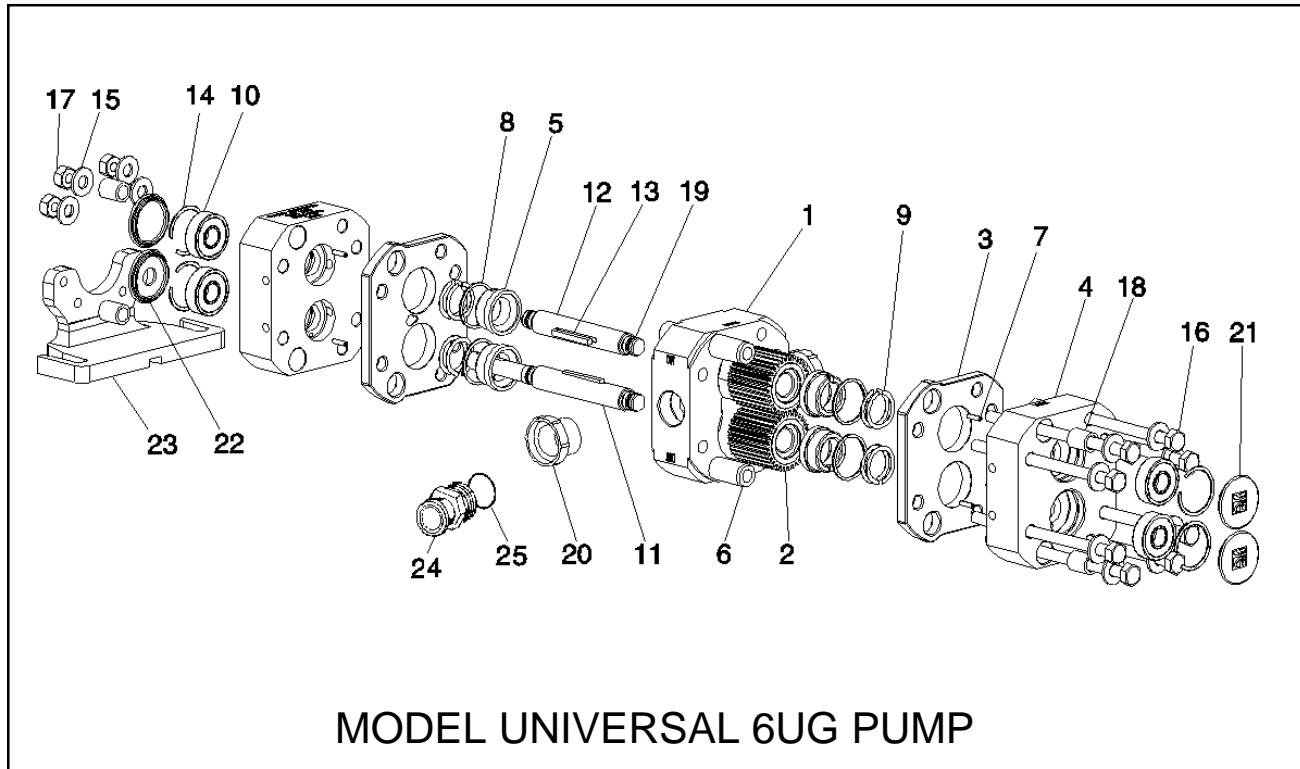

MODEL UNIVERSAL 6UG PUMP

ITEM	PART NUMBER	DESCRIPTION	QTY
1	108804	BODY	1
*2	107367	GEAR W/SEAL INSERTS	2
3	109301	WEAR PLATE - FRONT/ REAR	2
4	110924	COVER. FRONT/REAR	2
*5	105812	STATIONARY SEAL	4
6	105839	DOWEL, HOLLOW	2
7	30-124	ROLL PIN	4
*8	E70020	STATIONARY SEAL O-RING EPDM	4
	V70020	STATIONARY SEAL O-RING VITON®	4
	K75020	STATIONARY SEAL O-RING KALREZ®	4
*9	105813	WAVE SPRING	8
*10	108802	BEARING	4
11	107369	SHAFT, DRIVE.	1
12	107370	SHAFT, IDLER.	1
13	107376	KEY, DRIVE.	2
14	105820	RETAINING RING.	4
15	43-27	WASHER, 1/4" PLAIN	12
16	30-583	BOLTS 1/4-20	8
17	36-53	HEX NUT, 1/4-20	4
18	105821	DOWEL SPACER	2
*19	N70010	SHAFT O-RING FDA NITRILE	4
20	107479	CAPLUG	2
21	109425	CAP, BEARING	3
22	109426	CAP, BEARING-DRIVE SHAFT	1
23	109805	FOOT, MOUNTING	1
24	108218	S-LINE FITTING 3/4" (OPTIONAL)	2
25	USE SAME O-RINGS AS LISTED IN ITEM 8 (OPTIONAL)		2

*** RECOMMENDED SPARE PARTS**

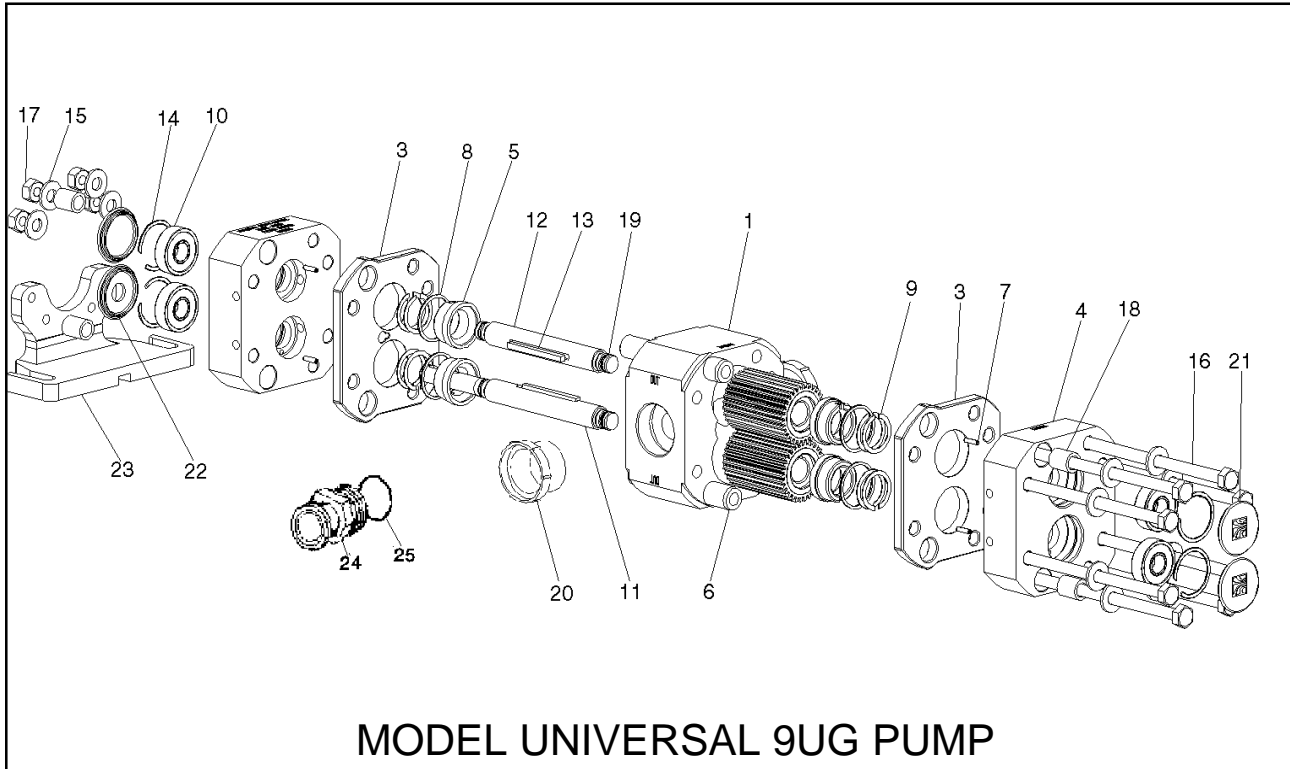

MODEL UNIVERSAL 9UG PUMP

ITEM	PART NUMBER	DESCRIPTION	QTY
1	108805	BODY	1
*2	107368	GEAR W/SEAL INSERTS	2
3	109301	WEAR PLATE - FRONT/ REAR	2
4	109424	COVER. FRONT/REAR	2
*5	105812	STATIONARY SEAL	4
6	110812	DOWEL, HOLLOW	2
7	30-124	ROLL PIN	4
*8	E70020	STATIONARY SEAL O-RING EPDM	4
	V70020	STATIONARY SEAL O-RING VITON®	4
	K75020	STATIONARY SEAL O-RING KALREZ®	4
*9	105813	WAVE SPRING	8
*10	108802	BEARING	4
11	107371	SHAFT, DRIVE.	1
12	107372	SHAFT, IDLER.	1
13	107377	KEY, DRIVE.	2
14	105820	RETAINING RING.	4
15	43-27	WASHER, 1/4" PLAIN	12
16	30-584	BOLT 1/4-20	8
17	36-53	HEX NUT, 1/4-20	4
18	105821	DOWEL SPACER	2
*19	N70010	SHAFT O-RING 010 FDA NITRILE	4
20	107480	CAPLUG	2
21	109425	CAP, BEARING	3
22	109426	CAP, BEARING-DRIVE SHAFT	1
23	109805	FOOT, MOUNTING	1
24	108219	S-LINE FITTING 3/4" (OPTIONAL)	2
25		USE SAME O-RINGS AS LISTED IN ITEM 8 (OPTIONAL)	2

* RECOMMENDED SPARE PARTS