



ADDENDUM FOR

Waukesha Pumps
UNIVERSAL LOBE
Model 054UL

**REFERENCE TABLES,
REPAIR PARTS &
ILLUSTRATED
PARTS LISTS**

NOTE: This addendum must be used with Manual 95-03017 Waukesha Universal Lobe Series pumps.

SECTION X REFERENCE TABLES AND REPAIR PARTS LIST

TABLE 1. STANDARD ROTOR CLEARANCES*- INCHES

MODEL	A BACK FACE	B ROTOR TO BODY	C FRONT FACE	ROTOR TO ROTOR
054UL	.003"	.004"	.006"	.010/.020

*For non-standard rotor clearance, contact Application Engineering at Waukesha Cherry-Burrell

TABLE 2. TORQUE VALUES-FT-LBS

MODEL	LOCK NUTS	
	GEAR	ROTOR
054UL	100	120

UNIVERSAL LOBE WRENCH SIZES - INCHES

MODEL	ROTOR NUT	*COVER NUT	BODY RETAINER BOLT
054UL	1-1/4"	5/8"	3/16"

* 3-WING NUT AVAILABLE

TABLE 3. SUGGESTED SHIMS - INCHES

SERIES MODEL	STANDARD SHAFT	REPLACEMENT SHAFT
054UL	0.105"	0.102"

LOCKING ASSEMBLY SCREWS FINAL TORQUE VALUE			
Model	Qty	Size	Torque
054UL	6	5mm	15 ft-lbs

TABLE 4. ARBOR OR HYDRAULIC PRESS REQUIRED (TONS)

SERIES MODEL	SHAFT		FRONT BEARING		REAR SHAFT	
	IN	OUT	ON	OFF	ON	OFF
054UL	0.25	0.5	0.5	1	0.5	1

O-RING INDEX

Model	Material	Inner Seal	Outer Seal	Shaft	Rotor Hub	Rotor Nut	Retainer Washer	Cover
054UL	Buna N	N70031	N70041	N70029	N70127	N70130	N70115	N70259
	EPDM	E70031	E70041	E70029	E70127	E70130	E70115	E70259
	Fluoroelastomer	V70031	V70041	V70029	V70127	V70130	V70115	V70259

SECTION XI PARTS LISTS

Illustrated Parts Identification for Universal Lobe Pumps

Model	Page
054UL	4-5
SINGLE MECHANICAL SEALS	6
DOUBLE MECHANICAL SEALS	7
SERVICE NOTES	8
LABEL PLACEMENT	9
PARTS ORDER INFORMATION.....	10

OPTIONAL PUMP FEATURES

Waukesha Universal Lobe pumps are available with optional features which affect the material/design (and part number) of certain parts. When ordering these parts, specify your pump serial number and part description to ensure getting the correct part. When converting from one design to another, contact Waukesha Customer Service with pump serial number.

SPECIAL NOTE

OPTIONAL FEATURE	DESCRIPTION	PARTS AFFECTED
Stainless Steel Gearcase	Gearcase, fasteners, and all associated parts made from stainless steel (no painted parts)	Gearcase, gearcase cover fasteners, mounting foot, nameplate, oil seals, oil plug
Seal Flush	Double shaft seal requires flush drilling/tapping in body	Body
Port Connections	Available port connections include; S-clamp, bevel seat, I-line, Q-line, DIN, flange	Body
Rotor	Material; Standard- alloy 88 Optional - 316 SS Clearances; Standard and Hot.	Rotor
Shaft Seal Components	Single Mechanical Double Mechanical	For materials available, See Pages 6-7

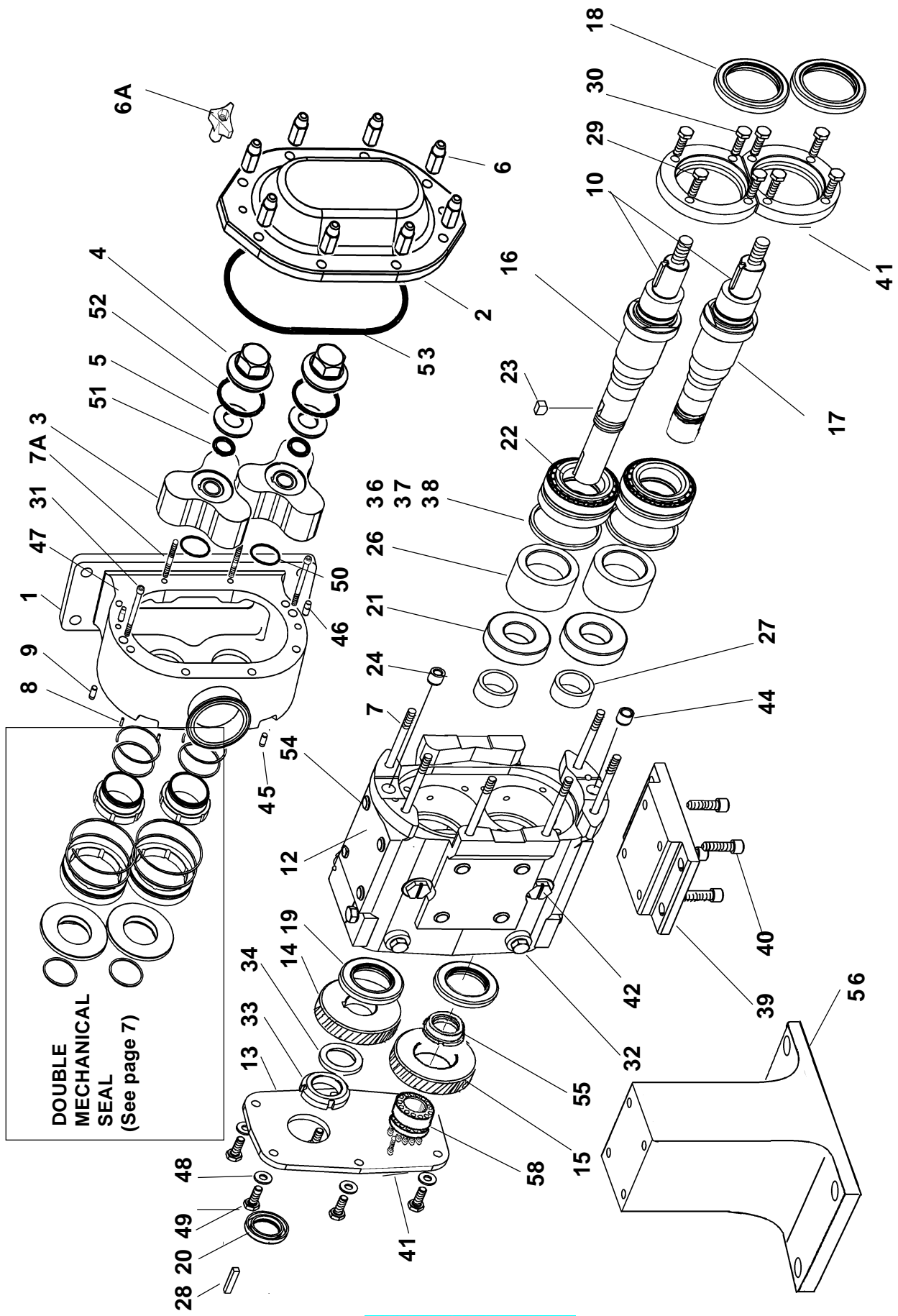

UNIVERSAL LOBE SERIES Model 054UL

ITEM	DESCRIPTION	PART NUMBER	QTY
1	**Body 054UL	109858	1
2	Cover,Standard Stainless	103214	1
3	**Rotor	109861	2
4	Rotor Nut	101805	2
5	Washer, Belleville	101692	2
6	Nut, Cover	108370	8
6A	Nut, 3W Wing Cover (Optional)	105851	8
7	Stud, Body	109865	6
7A	Stud, Body	35555	2
8	Stop Pin 303 SS	101719	6
9	Dowel Pin, Upper	BD0 040 200	1
10	Key, Rotor	109866	2
12	Gear Case	102277	1
	Gear Case, Stainless Steel	101833	1
13	Gear Case Cover	040 006 000	1
	Gear Case Cover, SS	102281	1
14	Gear, Shaft	107999	1
15	Gear, Drive	108000	1
16	Drive, Shaft	109859	1
17	Short, Shaft	109860	1
18	Seal, Front Grease	101717	2
	Seal, Front Grease	102289	2
19	Seal, Oil	000 030 014	2
20	Seal, Input	000 030 013	1
	Seal, Input, Stainless	102293	1
21	Bearing, Rear	030 035 000	2
22	Bearing, Front	101715	2
23	Key, Gear	BD0 037 000	1
24	Dowel Bushing, Upper	BD0 116 000	1
26	Spacer, Bearing	101815	2
27	Spacer, Gear	030 055 000	1
28	Key, Motor	000 037 002	1
29	Bearing Retainer, Front	101811	2
30	Cap Screw, Hex Hd. Zinc Plated	30-296	8
	Cap Screw, Hex Hd. 18-8	30-293	8
31	Cap Screw, Soc. Hd., Body 18-8	30-613	2
32	Oil Plug, 1/2-20 X 1/2	004 046 003	6
	Oil Plug, 1/2-20 X 1/2 18-8	30-526	6
	O-Ring, Buna N	N70112	6
33	Lock Nut	CD0 036 N00	1
34	Lockwasher	CD0 036 W00	1
36	Shim, Front Bearing 0.002"	030 054 002	4

ITEM	DESCRIPTION	PART NUMBER	QTY
37	Shim, Front Bearing 0.003"	030 054 003	4
38	Shim, Front Bearing 0.010"	030 054 010	2
	Shim, Front Bearing 0.050"	030 054 050	4
39	Mounting Foot, Gear Case	040 110 000	1
	Mounting Foot, Gear Case, SS	102283	1
40	Cap Screw, Soc. Hd. Zinc Plated	30-344	4
	Cap Screw, Soc. Hd. SS 18-8	30-189	4
41	Silicone Sealant, RTV	000 142 300	AR
42	Cleanout Plug 1-1/16-12	41013	2
	O-Ring, Buna	N70114	2
44	Bushing, Dowel, Lower	BD0 116 100	1
45	Dowel Pin, Lower	BD0 040 300	1
46	Dowel Pin, Cover, Lower	BD0 040 100	1
47	Dowel Pin, Cover, Upper	BD0 040 000	1
48	Washer, 3/8 ZP	43-194	6
49	HHCS, 5/16 -18 x .75 ZP	30-283	6
	HHCS, 5/16 -18 x .75 18-8	30-151	6
*	Name Plate	001 061 002	1
*	RHDS, #2 x 1/8" 18 8 S.S.	AD0 062 000	4
*	Grease Fitting	BD0 092 000	4
*	Grease Fitting 90° (Optional)	BD0 092 100	4
*	Plastic Cap, Grease Fitting	BD0 093 000	4
*	Caution Label	33-62	2
50	O-Ring, Rotor Hub, Buna N	N70127	2
	O-Ring, Rotor Hub, EPDM	E70127	2
	O-Ring, Rotor Hub, Fluoroelastomer	V70127	2
51	O-Ring, Washer Retainer Buna N	N70115	2
	O-Ring, Washer Retainer EPDM	E70115	2
	O-Ring, Washer Retainer Fluoroelastomer	V70115	2
52	O-Ring, Rotor Nut Buna N	N70130	2
	O-Ring, Rotor Nut EPDM	E70130	2
	O-Ring, Rotor Nut Fluoroelastomer	V70130	2
53	O-Ring, Cover Buna N	N70259	1
	O-Ring, Cover EPDM	E70259	1
	O-Ring, Cover Fluoroelastomer	V70259	1
54	Plug, Plastic, 3/8"	000 121 002	8
55	Lock Nut Sleeve	108201	1
56	Pedestal (Optional)	BD0 110 SMO	1
58	Locking Assembly	108784	1

**Special Note on page 3

* Not Shown AR= As Required
(Omit Item 48 on Stainless cases)

~~For Stainless Steel Gear Cases~~

UNIVERSAL LOBE SERIES Model 054UL

WAUKESHA UNIVERSAL LOBE PUMP

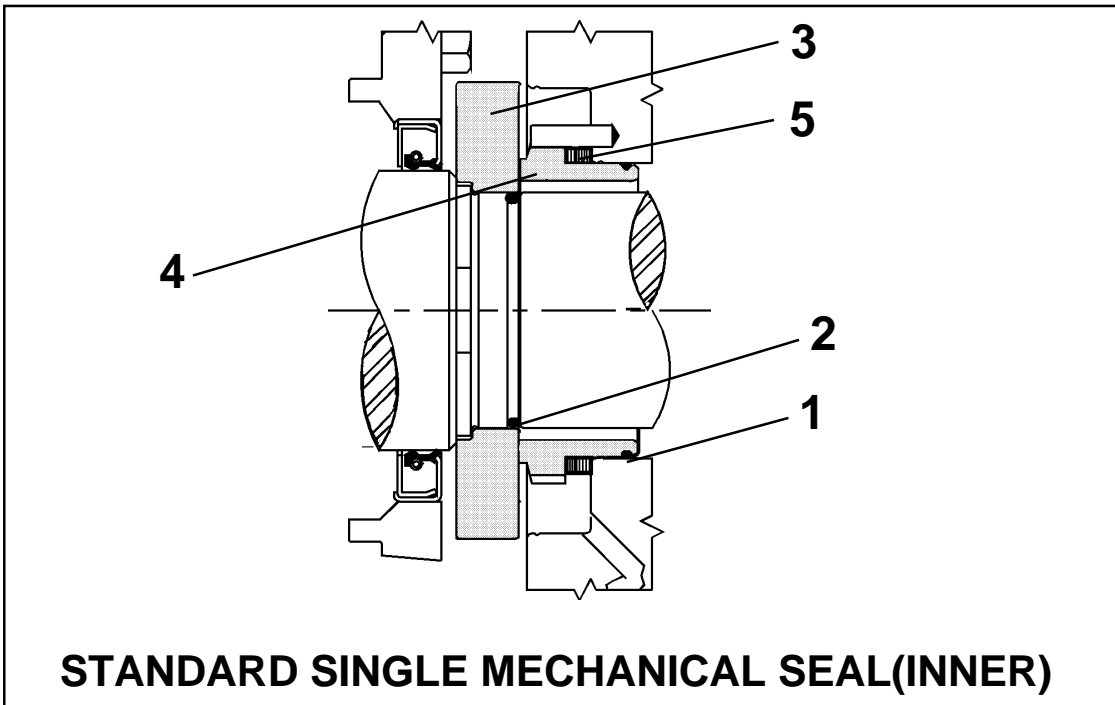

Model 054UL

Item	Description	Qty.	Part No.
1	O-Ring, Inner Buna N	2	N70031
	O-Ring, Inner EPDM	2	E70031
	O-Ring, Inner Fluoroelastomer	2	V70031
2	O-Ring, Shaft Buna N	2	N70029
	O-Ring, Shaft EPDM	2	E70029
	O-Ring, Shaft Fluoroelastomer	2	V70029
3	Seal Seat, Ceramic	2	101670
	Seal Seat, Silicon Carbide	2	101671
4	Seal Inner, Carbon	2	101655
	Seal, Inner, Ceramic	2	101656
	Seal, Inner, Tungsten Carbide	2	101658
	Seal, Inner, Silicon Carbide	2	101657
5	Wave Spring	2	101685

(Quantities are per pump)

WAUKESHA UNIVERSAL LOBE PUMP

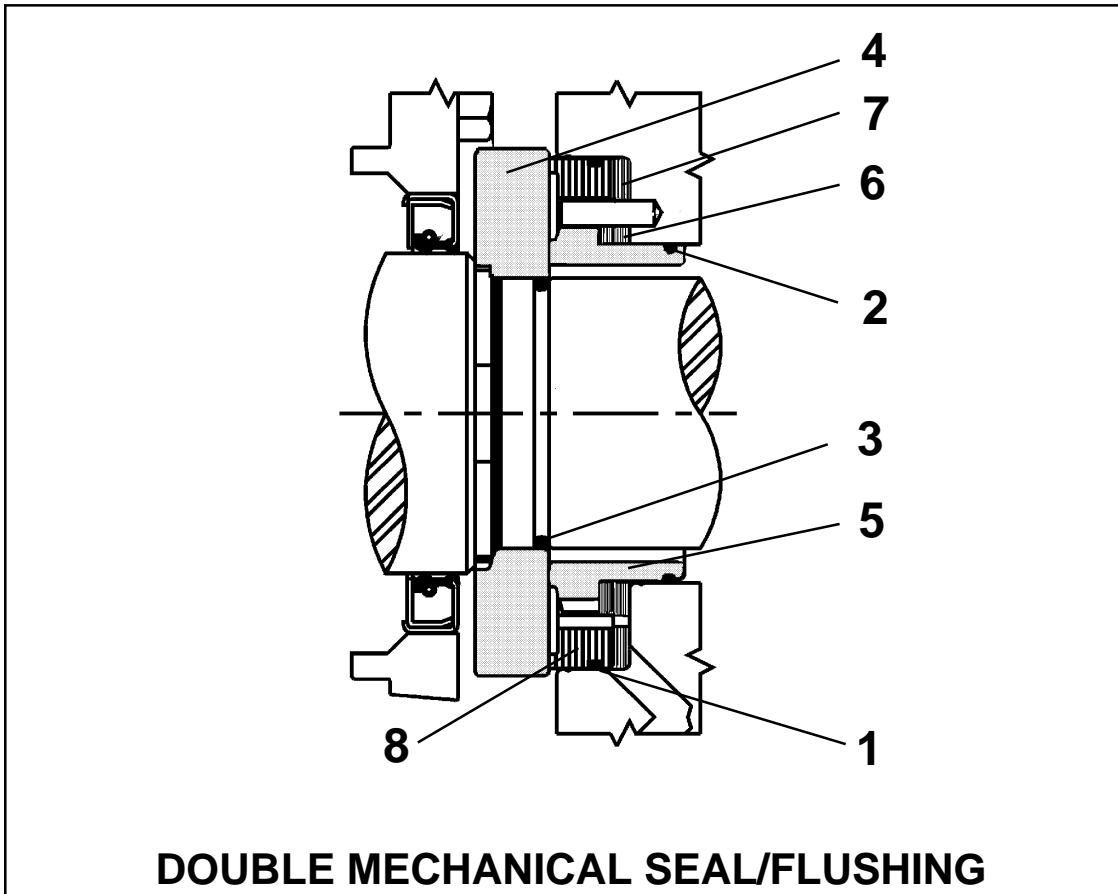

Model 054UL

Item	Description	Qty.	Part No.
1	O-Ring, Outer Seal Buna N	2	N70041
	O-Ring, Outer Seal EPDM	2	E70041
	O-Ring, Outer Seal Fluoroelastomer	2	V70041
2	O-Ring, Inner Seal Buna N	2	N70031
	O-Ring, Inner Seal EPDM	2	E70031
	O-Ring, Inner Seal Fluoroelastomer	2	V70031
3	O-Ring, Shaft Buna N	2	N70029
	O-Ring, Shaft EPDM	2	E70029
	O-Ring, Shaft Fluoroelastomer	2	V70029
4	Seal Seat, Ceramic	2	101670
	Seal Seal Silicon Carbide	2	101671
5	Seal, Inner, Carbon	2	101655
	Seal, Inner, Ceramic	2	101656
	Seal, Inner, Silicon Carbide	2	101657
	Seal, Inner, Tungsten Carbide	2	101658
6	Wave Spring, Inner	2	101685
7	Wave Spring, Outer	2	101686
8	Outer Seal, Carbon	2	101680

(Quantities are per pump)

NOTE: Pump Body for Flushing Required

CAUTION: This seal requires flushing to be connected and flowing before operating pump.

LABEL PLACEMENT

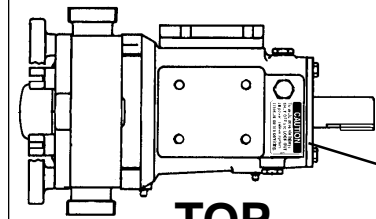

TOP

CAUTION
To avoid possible injury:
SHUT OFF and LOCK OUT
all power; relieve system
pressure before servicing.

CAUTION
To avoid possible injury;
SHUT OFF and LOCK OUT
all power; relieve system
pressure before servicing.

33-62

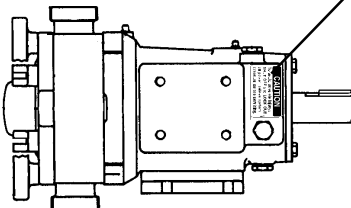

BOTTOM

1

WARNING
KEEP FINGERS
OUT OF PORTS

33-60

WARNING
KEEP FINGERS
OUT OF PORTS

33-61

WARNING
KEEP FINGERS
OUT OF PORTS

33-63

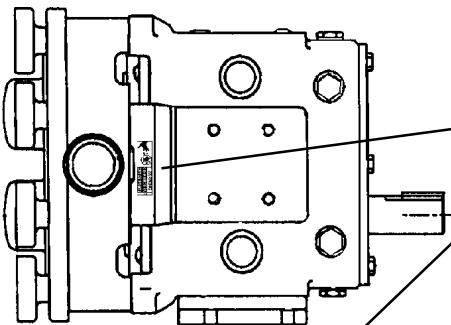

LEFT SIDE

WARNING
KEEP FINGERS
OUT OF PORTS

2

Relative Sizes

PUMP MODEL	1	2	
	33-62	33-60	33-63
054UL	●		●

● = 2 each

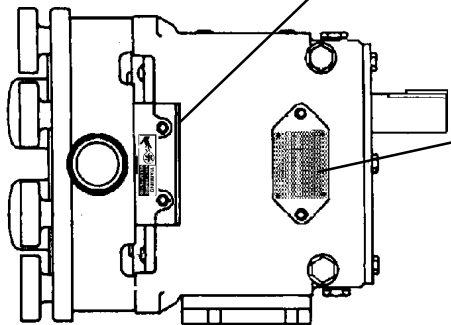

RIGHT SIDE

Part Number 001 061 002

Serial Number on Tag

Waukesha
Cherry-Burrell
A Tenneco Company
SERIAL NO. MODEL
READ AND UNDERSTAND
OPERATION AND MAINTENANCE
MANUAL BEFORE OPERATION.
Delavan, WI U.S.A. CE

APPLICATION INSTRUCTIONS

Apply to clean, dry surface. Remove backing; position in place, lay cover sheet over and burnish. (*Alternate method; Use soft rubber roller to press label in place.*)

Apply all labels to be readable from front of pump

Effective Date:
12-21-98