

# Universal II Industrial Series Rotary Positive Displacement ECP Pumps



# New levels of performance.

## Reduced operational and maintenance costs.

*For more than half a century, Waukesha Cherry-Burrell has been a leader in the design, manufacturing and application of external circumferential piston (ECP) style, rotary positive displacement pumps. Waukesha Cherry-Burrell PD pumps are installed in thousands of challenging chemical and industrial applications.*

*The Waukesha ECP positive displacement pump offers a number of unique advantages. The pump will easily handle settled slurries that can bind up lobe pumps or progressing cavity pumps. The pump imparts very low shear forces to the pumped product, far lower shear than lobe pumps or progressive cavity pumps. The pump is designed for 300° F and is not damaged by hot products. With flushed double mechanical seals, the pump can run dry for an extended period of time as there is no internal contact of rotors.*

*Now available with Composite Diamond Coating (CDC) for highly abrasive applications.*

### Features

- 316 stainless steel pump body and cover; 316L optional.
- **Exclusive, non-galling Waukesha “88” alloy rotors standard;** permits running at tighter clearances and pumping a wide range of viscosities. 316 stainless steel rotors also available.
- **No internal rotor contact** eliminates need to rely on pump fluid as a lubrication.
- **Rotor/shaft connection sealed** from product zone.
- **Mechanical seals standard.** Options include single, knife edge, low pressure flush, and high pressure barrier double seals.
- **Up to 500 (34.5 bar) psi pressure capability.**
- **Rotor nut** designed for extended service without loosening.
- **No bearings** in product zone.
- **Larger diameter 17-4 PH shafts** in seal area for greater strength and stiffness. Helps eliminate vibration; extends seal life. 316SS optional.
- **Heavy duty cast iron bearing frame. (Stainless steel available as an option)**
- **Double tapered roller bearings on all models.** Contribute further to precise rotor position and longer seal life.
- **Grease lubed bearings** for positive lubrication to all bearings over entire speed, temperature and pressure range.
- **Body retaining screws** for maintaining mechanical seal contact during inspection.
- **Remanufacturing Program** to extend life and reduce costs.

### Installation Features

- **Bi-directional flow.** Rotors, locked with unique washers and torqued nuts, rotate securely in either direction.
- **Interchangeable installation dimensions** with Universal 1 and Universal Lobe PD Series pumps.
- **Versatile 3-Way mounting** of gear case, including vertical alignment of ports.
- **Upper or lower drive shaft position.**



## Typical Applications

*Acids*

*Adhesives*

*Alkalies*

*Coatings*

*Emulsions*

*Glue*

*Ink*

*Lacquer*

*Latex*

*Oils & Lubricants*

*Paints*

*Polymers*

*Resins*

*Retention Aids*

*Sealants*

*Sludges*

*Slurries*

*Soaps*

*Solvents*

*Specialty Chemicals*

## Benefits of Universal U2 Series

- Pumps filled with most settled slurries will start without damaging pumps or seals.
- Expanded fluid cavities can pump liquids with large solids without jamming or knocking rotors out of timing.
- **Very low shear**, product not damaged during pumping.
- No internal rotor contact.
- Requires less horsepower than Progressing Cavity Pumps.
- Unique timing gear arrangement reduces troublesome maintenance issues as experienced on conventional lobe pumps.
- No cross contamination of lubricating oil into product zone due to unique gear case design.
- **Minimal heat added to product.**
- **Pumps are energy efficient**, and easily cleaned, maintained, and repaired.

### Optional:

- Composite Diamond Coating (CDC) for abrasive service.
- External over pressure valves for full flow relief.
- Bearing isolators.
- Tru-Fit integral gear motor drives.

# Performance and long life through engineering.

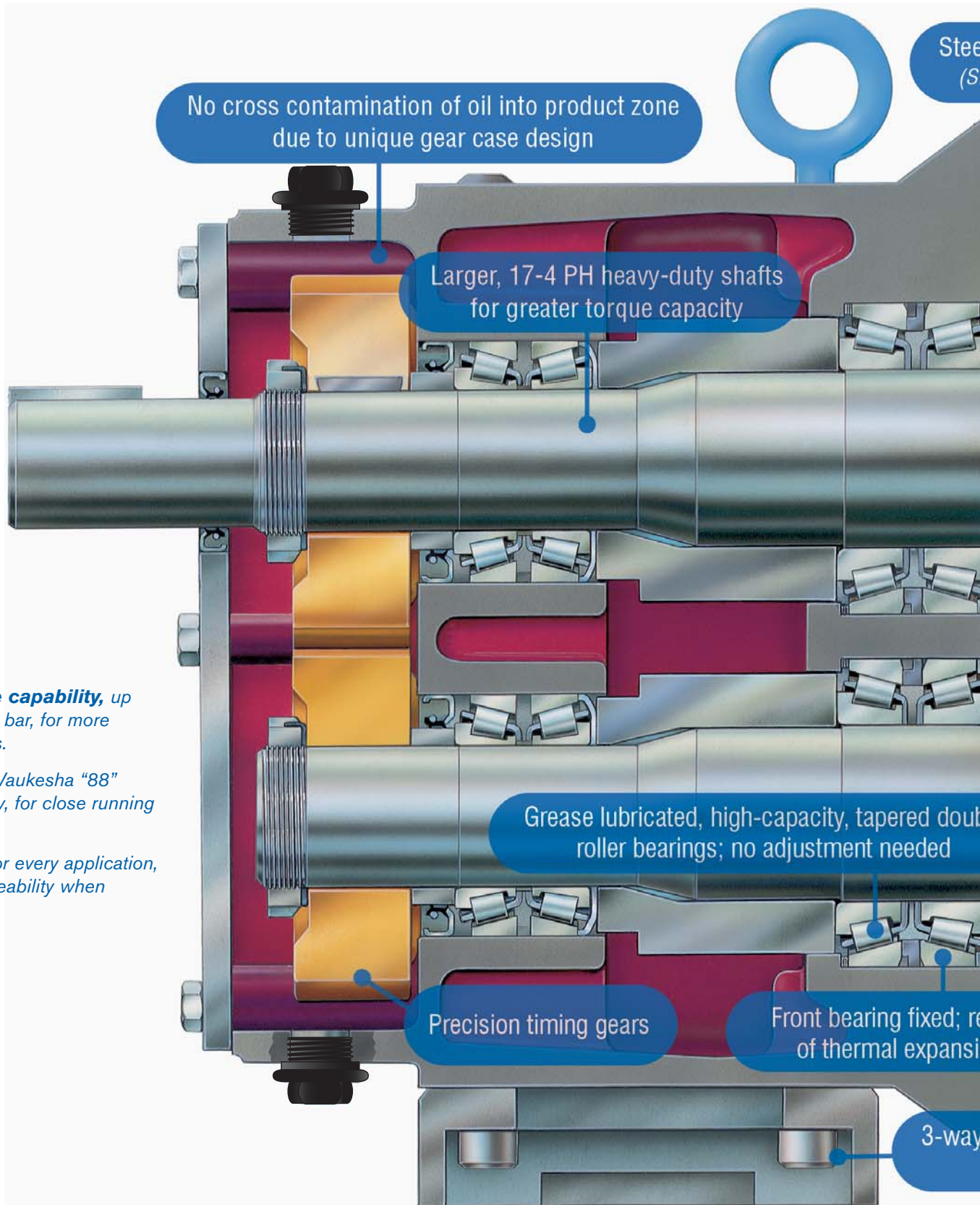

**High pressure capability**, up to 500 psi/34.5 bar, for more demanding jobs.

**Metal rotor:** Waukesha "88" non-galling alloy, for close running clearance.

The right seal for every application, plus interchangeability when needed.

Steel  
(S)

3-way

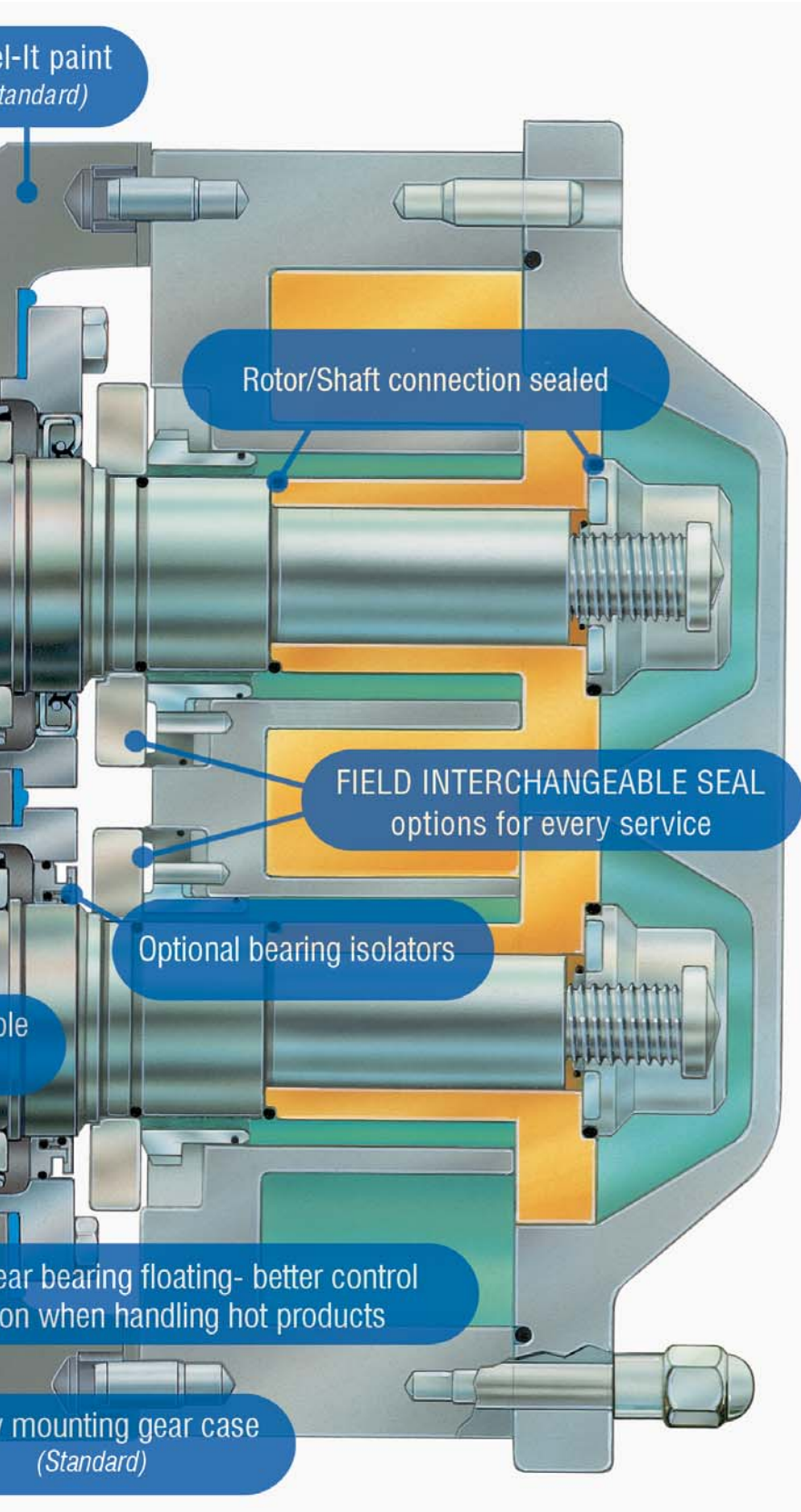

## Seal Options

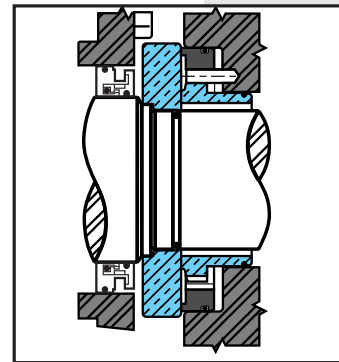

### Double Concentric Mechanical Seal\*

Used with flushing fluid to cool, lubricate, flush away residue. Best arrangement for severe service. Low pressure and high pressure flush double seals available.

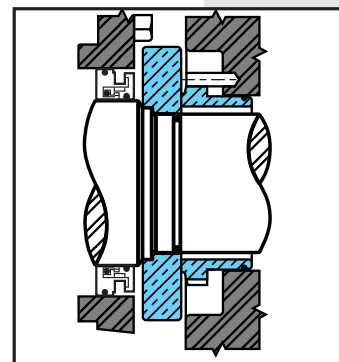

### Single Mechanical Seal\*

Carbon-to-ceramic faces standard. Alternate materials available for abrasive service. Standard and knife edge internal seal faces available.

#### Elastomers choices for "O" rings:

- Buna-N
- Fluoroelastomer (FKM)
- EPDM
- Silicone
- Perfluoroelastomer (FFKM)
- PTFE Encapsulated

#### \*Mechanical seal material options:

- Carbon
- Ceramic
- Silicon Carbide
- Tungsten Carbide

See Through Sight Glass for Quick Oil Level Check



Drain Plugs for Easy Service

# Specifications



**Universal U2 Pump**

MODEL	DISPLACEMENT PER REVOLUTION	NORMAL CAPACITY* TO	INLET/OUTLET	Optional Inlet/Outlet	Pressure Range Up To	Maximum RPM*	Temp Range
006-U2	.0082 GAL. (.031 LITER)	8 GPM (1.8 m <sup>3</sup> /hr.)	1"	1 1/2"	300 PSI (20.7 bar)	1000	(-)40F °C to 300 °F (149 °C)
015-U2	.0142 GAL. (.054 LITER)	11 GPM (2.5 m <sup>3</sup> /hr.)	1 1/2"	-----	250 PSI (17.2 bar)	800	
018-U2	.029 GAL. (.110 LITER)	20 GPM (4.5 m <sup>3</sup> /hr.)	1 1/2"	2"	200 PSI (13.8 bar)	700	
030-U2	.060 GAL. (.227 LITER)	36 GPM (8.2 m <sup>3</sup> /hr.)	1 1/2"	2"	250 PSI (17.2 bar)	600	
040-U2	.076 GAL. (.228 LITER)	46 GPM (10.4 m <sup>3</sup> /hr.)	2"	-----	150 PSI (10.50 bar)	600	
045-U2	.098 GAL. (.371 LITER)	58 GPM (13.2 m <sup>3</sup> /hr.)	2"	-----	450 PSI (31.0 bar)	600	
060-U2	.153 GAL. (.579 LITER)	90 GPM (20.4 m <sup>3</sup> /hr.)	2 1/2"	3	300 PSI (20.7 bar)	600	
130-U2	.253 GAL. (.958 LITER)	150 GPM (34.1 m <sup>3</sup> /hr.)	3"	-----	200 PSI (13.8 bar)	600	
180-U2	.380 GAL. (1.438 LITER)	230 GPM (52.2 m <sup>3</sup> /hr.)	3"	-----	450 PSI (31.0 bar)	600	
210-U2	.502 GAL. (1.900 LITER)	300 GPM (68.1 m <sup>3</sup> /hr.)	4"	-----	500 PSI (34.5 bar)	600	
220-U2	.521 GAL. (1.972 LITER)	310 GPM (70.4 m <sup>3</sup> /hr.)	4"	-----	300 PSI (20.7 bar)	600	
320-U2	.752 GAL. (2.847 LITER)	450 GPM (102 m <sup>3</sup> /hr.)	6"	-----	300 PSI (20.7 bar)	600	

\* For capacities above 450 to 830 GPM, see bulletin FH-1725 on 420/520 UHC (ECP Rotors)  
 Consult Waukesha Cherry-Burrell technical services for recommendations on your pumping requirements.

## Drive Option

**Close coupled Tru-Fit™ pump mounted on epoxy-painted base.**

- Features:**
- No shaft alignment necessary. No coupling guard required.
  - Reduces overall length of complete unit by an average of 20-25%.
  - Average of 20-25 gear ratios available per horsepower.
  - Separate oil sump for gear reducer and timing gears.

- Options:**
- NEMA or IEC frame motors available.  
 Right angle reducer also available for additional space savings.
  - 1/2 through 60 horsepower drive options available.
  - Horizontal or vertical porting.

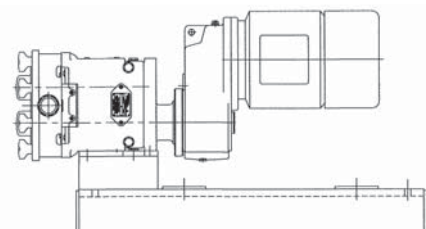

# Time-tested WCB rotary pump; external circumferential piston (ECP) operating principle

In the Waukesha Cherry-Burrell design, arc-shaped “pistons” (rotor wings) travel in annular-shaped cylinders machined in the pump body; the resulting long sealing path reduces slippage and produces a smooth flow of product without destructive pulses or pressure peaks and without valves or complex parts.

## Exclusive Waukesha Cherry-Burrell design features

**For Low Viscosity Fluids**, rotors, made of exclusive Waukesha “88” alloy, can be run with close clearance to the 316 stainless steel fluid head, without galling or seizing should inadvertent pressure surges cause contact. The close clearances combined with the rotor geometry, which gives a long sealing path between the pump inlet and outlet, means low slip operation. As a result, you achieve: high volumetric efficiency and good flow control.

**For High Viscosity Fluids**, the large fluid cavities of the rotors... plus the large, easy entry anti-cavitation ports... allow efficient pumping of high viscosity fluids, slurries or even liquids with large chunks or particles.

**For Non-Lubricating and Abrasive Fluids**, the unique Waukesha Cherry-Burrell design has no bearings in the fluid being pumped, no sliding or rolling contact and no rotor-to-rotor contact. This produces **MAXIMUM SERVICE LIFE** even under severe operating conditions.

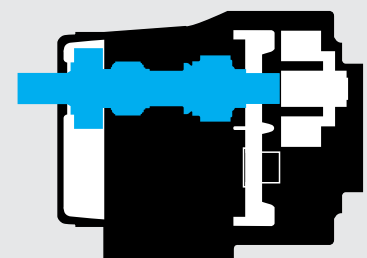
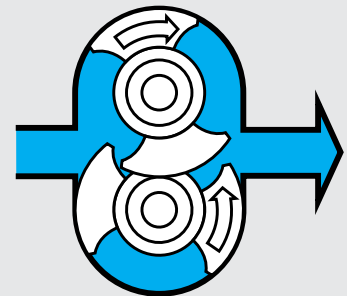
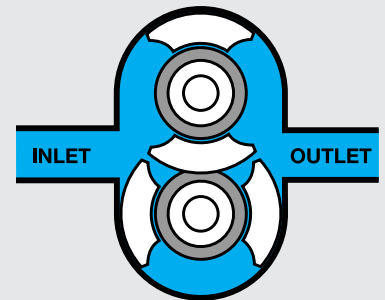
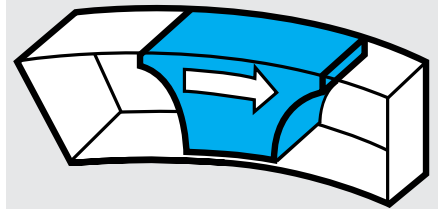

# Dimensions

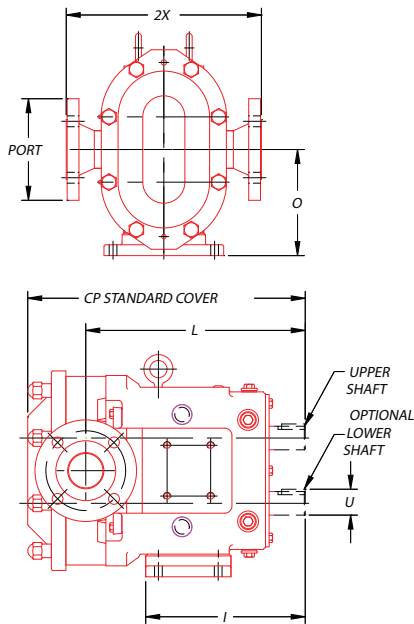

Pump Model		CP	I	L	O	Port Size	U +.000 -.001	150# FLG Connection
006-U2	IN	11.71	7.66	9.61	4.21	1"	.875	8.33
	MM	297	194	244	107	----	22.23	216
015-U2	IN	11.71	7.66	9.61	4.21	1½"	.875	8.33
	MM	297	194	244	107	----	22.23	216
018-U2	IN	12.37	7.66	10.48	4.21	1½"	.875	8.33
	MM	314	194	266	107	----	22.23	216
030-U2	IN	14.49	8.83	11.61	5.21	1½"	1.250	9.74
	MM	368	224	295	132	----	31.75	247
040-U2	IN	14.87	8.83	11.77	5.21	2"	1.25	9.74
	MM	378	224	305	132	-----	31.75	247
045-U2	IN	18.59	10.99	14.86	7.31	2"	1.625	13.58
	MM	472	279	377	186	----	41.28	344
060-U2	IN	19.14	10.99	15.14	7.31	2½"	1.625	13.58
	MM	486	279	385	186	----	41.28	344
130-U2	IN	20.15	10.99	15.77	7.31	3"	1.625	13.58
	MM	512	279	401	186	----	41.28	344
180-U2	IN	23.26	14.80	18.25	9.38	3"	2.000	15.76
	MM	591	376	464	238	-----	50.80	400
210-U2	IN	27.08	17.80	21.24	10.38	4"	2.375	15.76
	MM	688	452	539	264	-----	60.45	400
220-U2	IN	24.00	14.80	18.49	9.38	4"	2.000	15.76
	MM	610	376	470	238	----	50.80	400
320-U2	IN	27.66	17.80	21.63	10.38	6 150# FLG	2.375	16.00
	MM	703	452	549	264	----	60.45	406



ISO 9001  
CERTIFIED



**SPX**®

**PROCESS EQUIPMENT**

SPX Process Equipment, Waukesha Cherry-Burrell Operation  
 611 Sugar Creek Road, Delavan, WI 53115  
 Phone: (262) 728-1900 or (800) 252-5200, Fax: (262) 728-4904  
 E-mail: wcb@spx.com

**Packaging - Processing**  
**Bid on Equipment**  
 1-847-683-7720  
[www.bid-on-equipment.com](http://www.bid-on-equipment.com)

For more information about our worldwide locations, approvals, certifications, and local representatives, please visit [www.spxpe.com](http://www.spxpe.com).

SPX Corporation reserves the right to incorporate our latest design and material changes without notice or obligation. Design features, materials of construction and dimensional data, as described in this bulletin, are provided for your information only and should not be relied upon unless confirmed in writing.

Issued: 5/2009 FH-1750

Copyright © 2009 SPX Corporation