

Waukesha Cherry-Burrell

Shear Pump

For continuous,
inline and controller batch
coarse processing

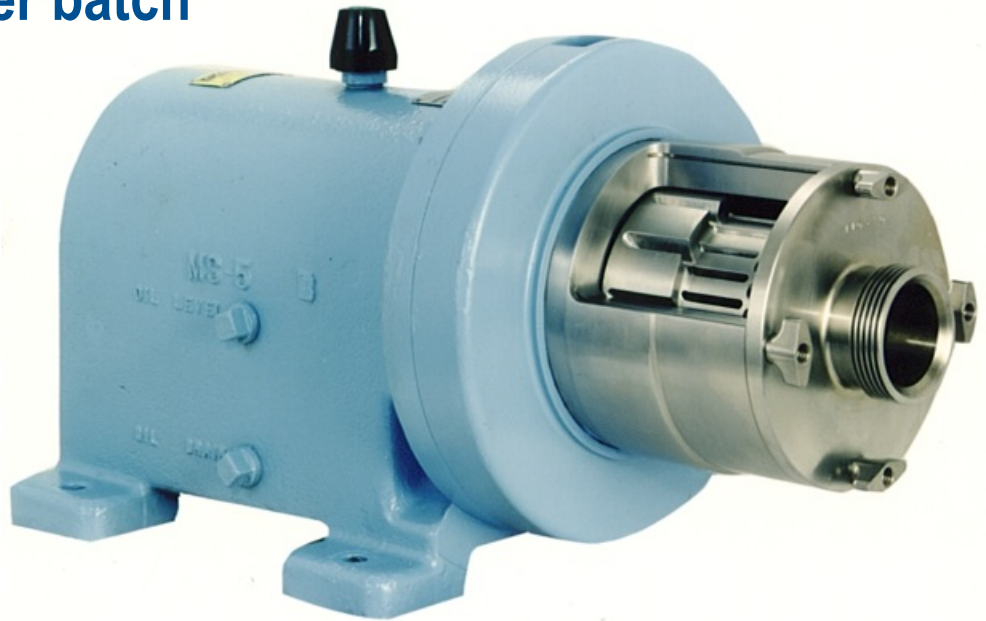

- **Processes as it pumps**

Economical Waukesha Cherry-Burrell Shear Pumps combine product transfer with many involved and otherwise expensive processing operations. A complete predictable action produces mechanical, hydraulic, ultrasonic and controlled cavitation phenomena for dependable, uniform inline or batch processing with no aeration.

- **Versatile**

Rate of flow through a controllable stator rotor arrangement, coupled with pump RPM, determines the ultimate effect on your product. No complicated adjustments are necessary. Merely select from a variety of modularly interchangeable stator and rotor combinations. Product quality control is built into the design.

Depending upon the setup you choose, you can texturize, emulsify, blend, reconstitute, suspend, disperse or polish all the time maintaining constant discharge pumping rates.

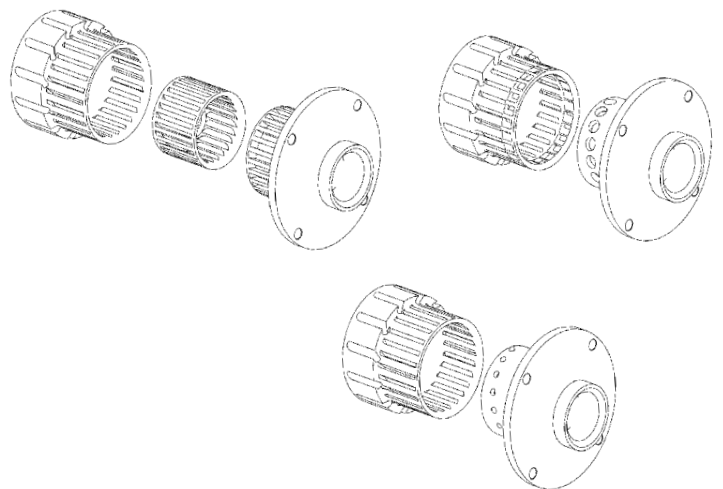

Interchange modular stators and rotors to achieve desired effect.



Typical applications

Texturizes: gives a smooth body and texture to such products as ricotta cheese and food pastes. Use of various rotor/stator combinations and/or adjustment of rotor speed provide precise control of texturizing effect.

Emulsifies: makes stable emulsions of products with both oil and water base ingredients. The requirements for stabilizer and/or emulsifier additives may be reduced.

Blends: provides continuous, online blending without air incorporation or lumps of dry product. Extremely uniform blending is achieved.

Reconstitutes: assists reconstitution of powdered products, such as milk powders. Recirculation with Shear Pump provides faster and more complete solution.

Suspends/Disperses: gives stable solids in liquid suspensions. Particle size reduction is also possible. Provides uniform dispersion of products, such as dyes.



Easy disassembly and reassembly for cleaning.

Shear Pump Dimensions

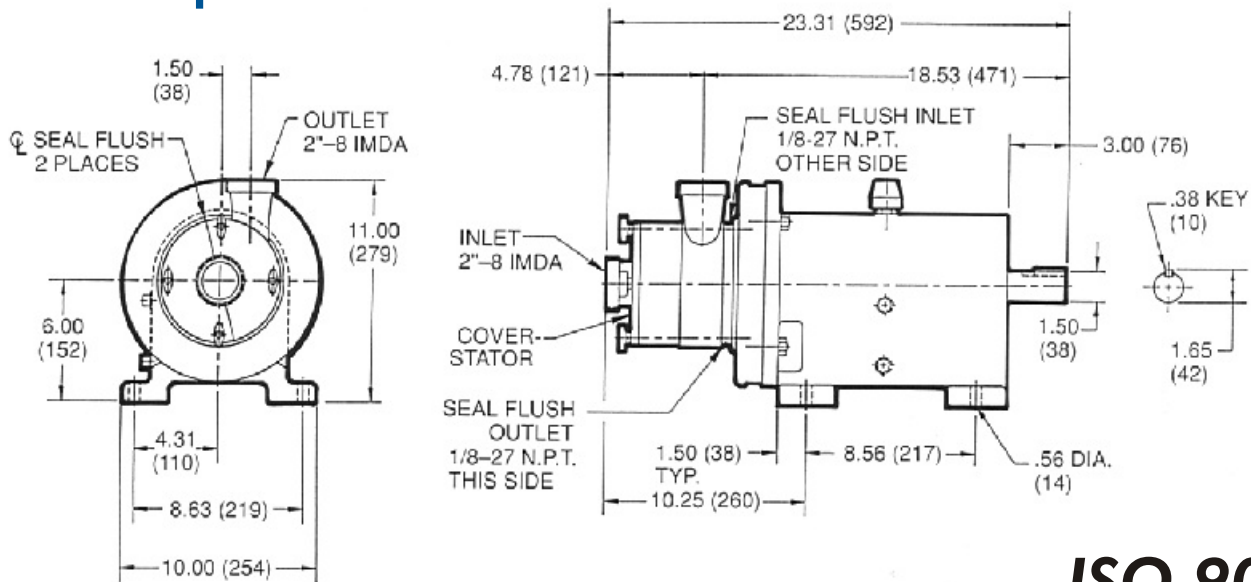

611 Sugar Creek Road
 Delavan, WI 53115
 Tel: 1.800.252.5200 or 262.728.1900
 Fax: 1.800.252.5012 or 262.728.4904
 E-mail: custserv@gowcb.com
 Web site: <http://www.gowcb.com>

Waukesha Cherry-Burrell Warranty

Seller warrants its products to be free from defects in materials and workmanship for a period of (1) year from the date of shipment. This warranty shall not apply to products which require repair or replacement due to normal wear and tear or to products which are subjected to accident, misuse or improper maintenance. This warranty extends only to the original buyer. Products manufactured by others but furnished by seller are exempted from this warranty and are limited to the original manufacturer's warranty.