



**READ AND UNDERSTAND THIS MANUAL PRIOR
TO INSTALLING OR OPERATING THIS PUMP.**



**WAUKESHA
SHEAR PUMP**

**OPERATION
MAINTENANCE
& PARTS LIST**

SAFETY

Warnings, cautions and notes are contained in this manual. To avoid serious injury and/or possible damage to equipment, pay attention to these messages.

WARNING Hazards or unsafe practices which COULD result in severe personal injury or death and how to avoid it.

CAUTION Hazards or unsafe practices which COULD result in minor personal injury or product or property damage.

NOTE Important information pertaining directly to the subject.
(Information to be aware of when completing the task.)

WARNING
Stop Machinery to Clean,
Service or Repair

CAUTION
PUMP PARTS HAVE SHARP EDGES.
TO AVOID CUTTING INJURY, WEAR GLOVES
AND HANDLE PARTS CAREFULLY.

WARNING
To avoid electrocution, ALL electrical should
be done by a registered Electrician, following
Industry Safety Standards.
All power must be OFF and LOCKED OUT
during installation.

WARNING
TO AVOID POSSIBLE SERIOUS INJURY,
SHUT OFF AND DRAIN PRODUCT FROM
PUMP PRIOR TO DISCONNECTING PIPING.

CAUTION
To avoid possible injury;
SHUT OFF and LOCK OUT
all power; relieve system
pressure before servicing.

REPLACEMENT LABEL

WARNING
TO AVOID SERIOUS INJURY, DO NOT
INSTALL OR SERVICE PUMP UNLESS
ALL POWER IS OFF AND LOCKED OUT.

**WARNING**
KEEP FINGERS
OUT OF PORTS

REPLACEMENT LABEL

Read and understand this manual prior to
installing, operating or maintaining this pump.

WAUKESHA CHERRY-BURRELL WARRANTY

Seller warrants its products to be free from defects in materials and workmanship for a period of one (1) year from the date of shipment. This warranty shall not apply to products which require repair or replacement due to normal wear and tear or to products which are subjected to accident, misuse or improper maintenance. This warranty extends only to the original Buyer. Products manufactured by others but furnished by Seller are exempted from this warranty and are limited to the original manufacturer's warranty.

Seller's sole obligation under this warranty shall be to repair or replace any products that Seller determines, in its discretion, to be defective. Seller reserves the right either to inspect the products in the field or to request their prepaid return to Seller. Seller shall not be responsible for any transportation charges, duty, taxes, freight, labor or other costs. The cost of removing and/or installing products which have been repaired or replaced shall be at Buyer's expense. Seller expressly disclaims all other warranties, express or implied, including without limitation any warranty of merchantability of fitness for a particular purpose. The foregoing sets forth Seller's entire and exclusive liability, and Buyer's exclusive and sole remedy, for any claim of damages in connection with the sale of products. In no event shall Seller be liable for any special consequential incidental or indirect damages (including without limitation attorneys' fees and expenses), nor shall Seller be liable for any loss of profit or material arising out of or relating to the sale or operation of the products based on contract, tort (including negligence), strict liability or otherwise.

LIST OF CONTENTS

SAFETY	3	FLUSHING	
WARRANTY	4	NO FLUSH	10
GENERAL INFORMATION	6	CASCADE FLUSH	10
Shipping Damage	6	CONTAINED FLUSH	10
Warranty Claims	6	START-UP CHECK LIST	10
Ordering Parts	20	PERFORMANCE CHART	11
Returning Parts	20	OPERATION	12
INTRODUCTION	6	SPECIFIC PROCESSING USES	12-13
SPECIFICATIONS	6	Product Combinations	12
THEORY OF OPERATION	7	Available Head Components	13
Seal Flushing	7	MAINTENANCE	14
Main Pump Components	7	LUBRICATION	10-17
TYPICAL APPLICATIONS	8	TRUBLESHOOTING	14
INSTALLATION	8	WET END DISASSEMBLY	15
DIMENSIONS, SHEAR PUMP	8	WET END ASSEMBLY	16
DIMENSIONS, MOTOR BASE ASS'Y	8	GEAR CASE SERVICE	17
LOCATION	8	LUBRICATION	17
COUPLING ALIGNMENT	8	SERVICE PREPARATION	17
ALIGNMENT TO DRIVE	9	FRONT SEAL REPLACEMENT	17
ROTATION DIRECTION	8-9	REAR BEARING REPLACEMENT	17
PIPING LAYOUT	9-10	PARTS LISTS	
A. Support	9	SHEAR PUMP WITH FLUSHING	18
B. Thermal Expansion	9	SHEAR PUMP BASE ASSEMBLY	19
C. Piping Layout	10	PARTS ORDERING	20
D. Isolation Valves	10		
E. Pressure Gauges	10		

GENERAL INFORMATION

MANUAL FORMAT

Read this Manual to familiarize yourself with the subjects of each Section. Whether installing, operating, troubleshooting, maintaining or ordering parts, read carefully to understand that section and follow instructions.

SHIPPING DAMAGE

Inspect your shipment immediately. If shipping damage is found, note it on the drivers copy (packing slip) and request the driver to ask the Inspector to call. You are responsible for initiating shipping damage claims.

HIDDEN DAMAGE

If during installation, you discover hidden damage caused in shipping, contact the Shipper immediately and ask for an Inspector to call. Notify your Distributor of the problem.

WARRANTY CLAIM

Please read the Warranty statement to correctly determine if you have a claim. In warranty claims you must have a "Returned Goods Authorization" (RGA) from the manufacturer before any returns will be accepted. Your Distributor will help you with a warranty problem.

ORDERING/RETURNING PARTS

See page 20 for complete information on ordering and returning parts. Complete Distributor/Product information immediately and keep for later reference.

INTRODUCTION

Shear Pump Model 4

The WAUKESHA Shear Pump is designed for "on-line", continuous shearing and mixing action. (See TYPICAL APPLICATIONS) A choice of modularly interchangeable stators and rotors make it versatile for processing a wide variety of products. Variable speed drives may also be used to further adjust the shear and mixing affect.

SPECIFICATIONS

CONSTRUCTION FEATURES

Body..... 316 stainless steel
Stator/Rotor 316 stainless steel
Shaft 316 stainless steel
Front Bearing Double Taper Timken®
Rear Bearing..... Double Roller Ball
Seals Mechanical Face-type
Seal Flush Optional
Inlet/discharge ..2" IMDA Sanitary threaded
..... male
Discharge Direction..Adjustable at 90° intervals

NOTE: Inner rotor can be replaced with blade type or spacer, depending on results desired. (For suggested combinations, see OPERATING SECTION.)

Various types of port fittings are available.

PRODUCT PARAMETERS

Maximum Housing Pressure

150 PSI (10 BAR)

Nominal Capacity

To 30 GPM (114 LITERS/MIN.)

Viscosity Range

Limited only to the maximum 150 psi pressure to force feed the pump.

Nominal Temperature Range

To 300°F (149°C)

Nominal Speed

3600RPM (5200RPM Max.)

Rotation

Counterclockwise (Viewed from front)

(See page 9 and 19 for pumps assemblies mounted on motor/bases.)

THEORY OF OPERATION

Product enters (1) stationary Cover Stator inlet port; proceeds into counterclockwise rotating (2) Inner Rotor where it is forced through Inner Rotor openings and meets (3) stationary Cover Stator openings. It is forced outward through these slotted openings into the counterclockwise rotating (4) Outer Rotor openings before exiting through (5) body discharge port.

NOTE: Body discharge port may be positioned at any 90° interval desired.

A high degree of shearing can occur at points (2), (3) and (4). The actual amount of shearing depends on:

1. Product.
 - a. High viscosity product shearing is affected by number and size of rotor openings.
 - b. Low viscosity product moves rapidly through shear pump with less shearing but more pumping action.
2. Speed of inner/outer rotors creates more (fast) or fewer (slow) shearing passes through product.

NOTE: Typical speed is 3600 RPM.
 Rated speed is to 5200 RPM.

3. Rate of product flow affects shearing action.
 - a. Slow moving product, more shearing.
 - b. Fast moving product, less shearing.

NOTE: For most products a separate *positive displacement supply pump is required to control shearing processes and discharge pressures.

*Shear pump can be used alone by installing close to a supply tank and recirculating product until the desired shear is achieved (provided finished viscosity is not too high; approximately 500 cps).

NOTE: The mechanical energy supplied to the product by the Shear pump will cause a typical temperature increase of 2°-10° F. (1°-5° C.).

SEAL FLUSHING

The Shear pump is equipped with 1/8 NPT female seal flushing ports at the top and bottom of the body. (See Figure 4) Cool filtered water is generally preferred for most applications. (Warm water if fats and waxes build up in seal area.) Flow rate should not exceed 1/4 gallon per minute.

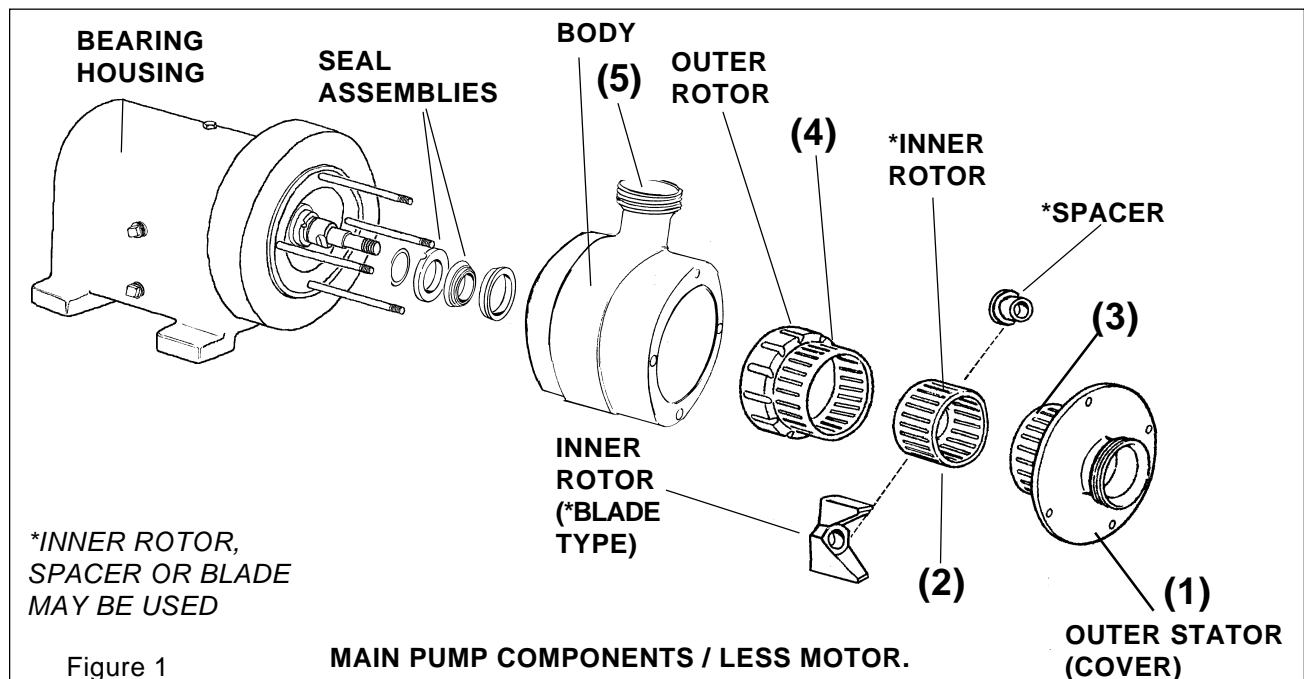

TYPICAL APPLICATIONS

Texturizes; gives a smooth body and texture to such products as ricotta cheese and food pastes. Use of various rotor/stator combinations and/or adjustment of rotor speed provide precise control of texturizing effect.

Emulsifies; makes stable emulsions of products with both oil and water base ingredients. The requirements for stabilizer and/or emulsifier additives may be reduced.

Blends; provides continuous, on-line blending without air incorporation or lumps of dry product. Extremely uniform blending is achieved.

Reconstitutes; assists reconstitution of powdered products such as milk powders. Recirculation with Shear Pump provides faster and more complete solution.

Suspends/Disperses; gives stable solids in liquid suspensions. Particle size reduction is also possible. Provides uniform dispersion of products such as dyes.

Polishes; improves the appearance of products by providing a smoother and more uniform surface texture.

INSTALLATION Shear Pump Dimensional Data

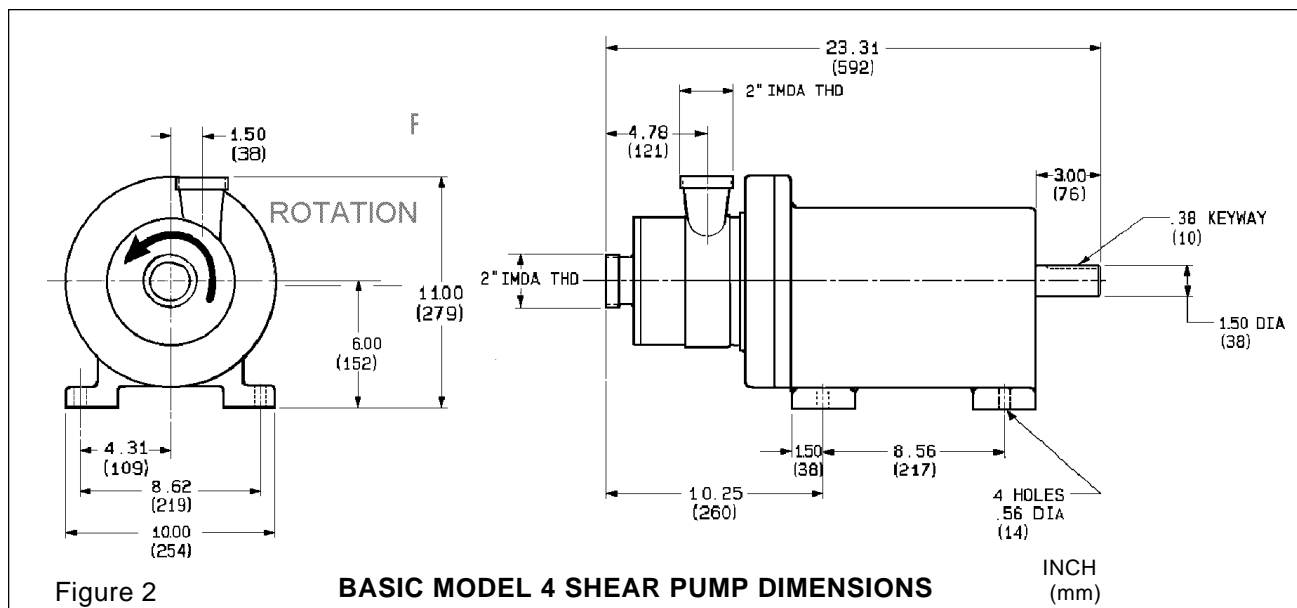

INSTALLATION - CONTINUED

Motor Base Assembly Dimensions

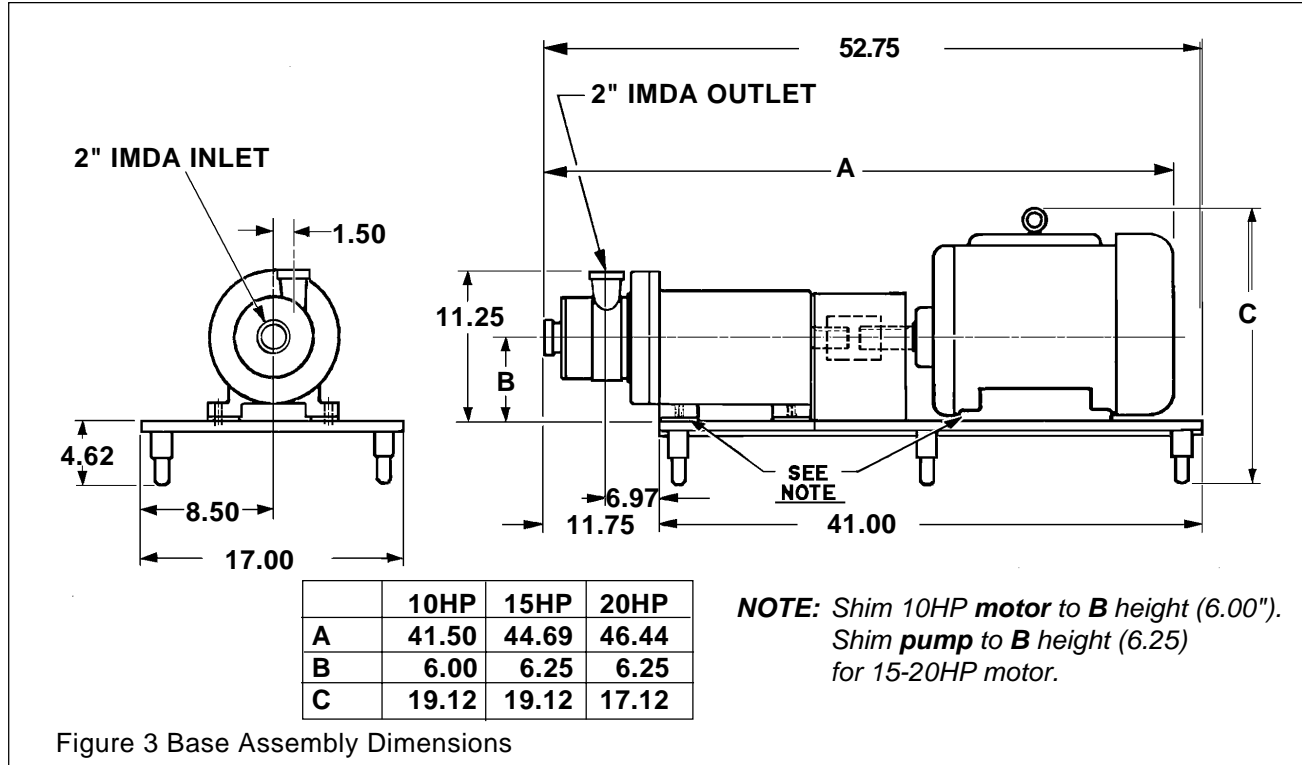

LOCATION

1. Locate Shear pump as near to the liquid source as practical to keep suction piping to a minimum. *(Short and direct with few elbows and fittings minimize head loss due to friction.)*
2. Unit should be accessible for inspection, cleaning and servicing. *(Protect motor from flooding.)*

COUPLING ALIGNMENT

Units are shipped with coupling aligned. However, check for angular, parallel and angular/parallel misalignment, before putting them in service.

a. Check angular alignment by turning coupling and measuring gaps between coupling halves at 1/4, 1/2 and 3/4 turn. Maximum recommended gap is .030 in. (.076mm)

b. Check parallel misalignment by placing a straight edge parallel to shafts across both coupling halves. Check at 90 degree intervals around coupling. Shim drive to match pump shaft. Parallel offset of .015 in. (0.38mm) is maximum.

Follow manufacturers' recommendations for couplings supplied by others.

CAUTION

**PUMP PARTS HAVE SHARP EDGES.
 TO AVOID CUTTING INJURY, WEAR GLOVES
 AND HANDLE PARTS CAREFULLY.**

WARNING

To avoid electrocution, ALL electrical installation should be done by a registered Electrician, following all safety practices. All power must be OFF and LOCKED OUT during installation.

Check pump rotation direction. (Figure 2) Visually check rotation direction after wiring. Jog motor only enough to determine rotation direction. *When facing the inlet port, pump should rotate in a counterclockwise direction.*

CAUTION

TO AVOID INJURY, DO NOT INSERT FINGERS INTO PUMP PORTS.

PIPING

Good piping practice minimize forces exerted on the pump, that can cause misalignment of pump parts and lead to excessive wear of rotors, stators, bearings and shafts.

A. Support:

Use independent hangers or pedestals to support weight of Shear pump, piping and fluid.

B. Thermal Expansion:

When necessary, use thermal expansion joints to minimize forces on pump. *(Expansion can cause tremendous forces.)*

(Use flexible joints to limit the transmission of mechanical vibration. Anchor free ends of all flexible hose in system.)

INSTALLATION - CONTINUED

C. Piping Layout:

- INLET-** 1. Slope piping up to inlet to avoid air pocket.
 2. When necessary, use check valves to keep inlet line full, particularly with low viscosity fluids, and in start-stop operation.

D. "Isolation" Valves: Allow for pump maintenance and removal safely without emptying entire system.

E. Pressure Gauges:

Pressure and "Vacuum" gauges provide the easiest way to check pump operation.

- Normal or abnormal pressures
- Overload conditions
- Indication of flow
- Changes in pump condition
- Changes in system conditions
- Changes in fluid viscosity

Wherever possible-install gauges!!

Flushing Connection:

Shaft seal flushing is recommended when processing abrasive, hot, sticky and/or products that crystallize upon drying. The three choices are:

1. **NO FLUSHING:** Remove O-Ring and Sleeve (Items 1 & 2, page 18).
2. **CASCADE FLUSHING:** (*into top, out bottom*): Remove the O-Ring and Sleeve. Connect proper piping and valve to 1/8 NPT tapped ports. (See Figure 4)
3. **CONTAINED FLUSHING:** Install O-Ring, Sleeve and connect piping and valve to tapped ports. (*Flow is into bottom; out of top.*)

Use cool filtered water for most applications. (*Warm water if fats and waxes build up in seal area.*) Flow rate should not exceed 1/4 gallon per minute.

NOTE: When feeding with positive displacement pump, **DO NOT exceed 150 PSI** through Shear Pump

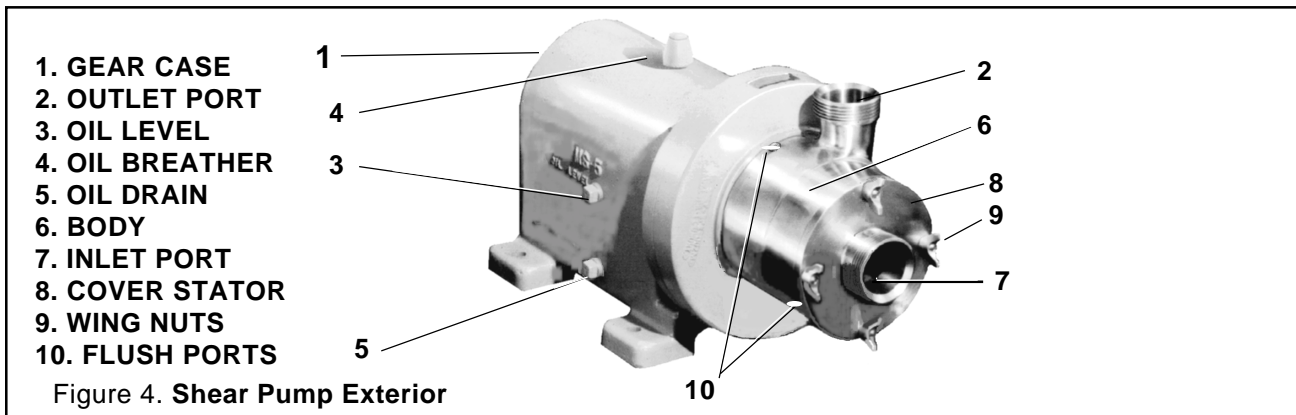

START-UP CHECK LIST

CAUTION

**PUMP PARTS HAVE SHARP EDGES.
 TO AVOID CUTTING INJURY, WEAR GLOVES
 AND HANDLE PARTS CAREFULLY.**

Lubrication

Prior to starting - Check oil level in bearing housing. (See Figure 4)

NOTE: The bearing housing of the Shear Pump should be lubricated with D.T.E. BB. Mobil mineral oil or equivalent.

Piping and pump are clean and free of foreign material, such as welding slag, gaskets, etc.

NOTE: If pumping does not begin and stabilize, check items under "No" or "Insufficient Discharge" in Pump Troubleshooting Section (Page 14).

Piping connections are tight and leak free. Where possible, check system with "nonhazardous" fluid.

All guards are in place and secure.

Turn on seal flushing fluid prior to starting pump.

Open all valves on inlet side, so fluid can reach pump and open all valves on discharge system for free flow to destination.

Start pump. (Variable speed pump drive at slow speed.) Rotation is counterclockwise!

Liquid is reaching pump.

PERFORMANCE CHART

No 4 Shear Pump

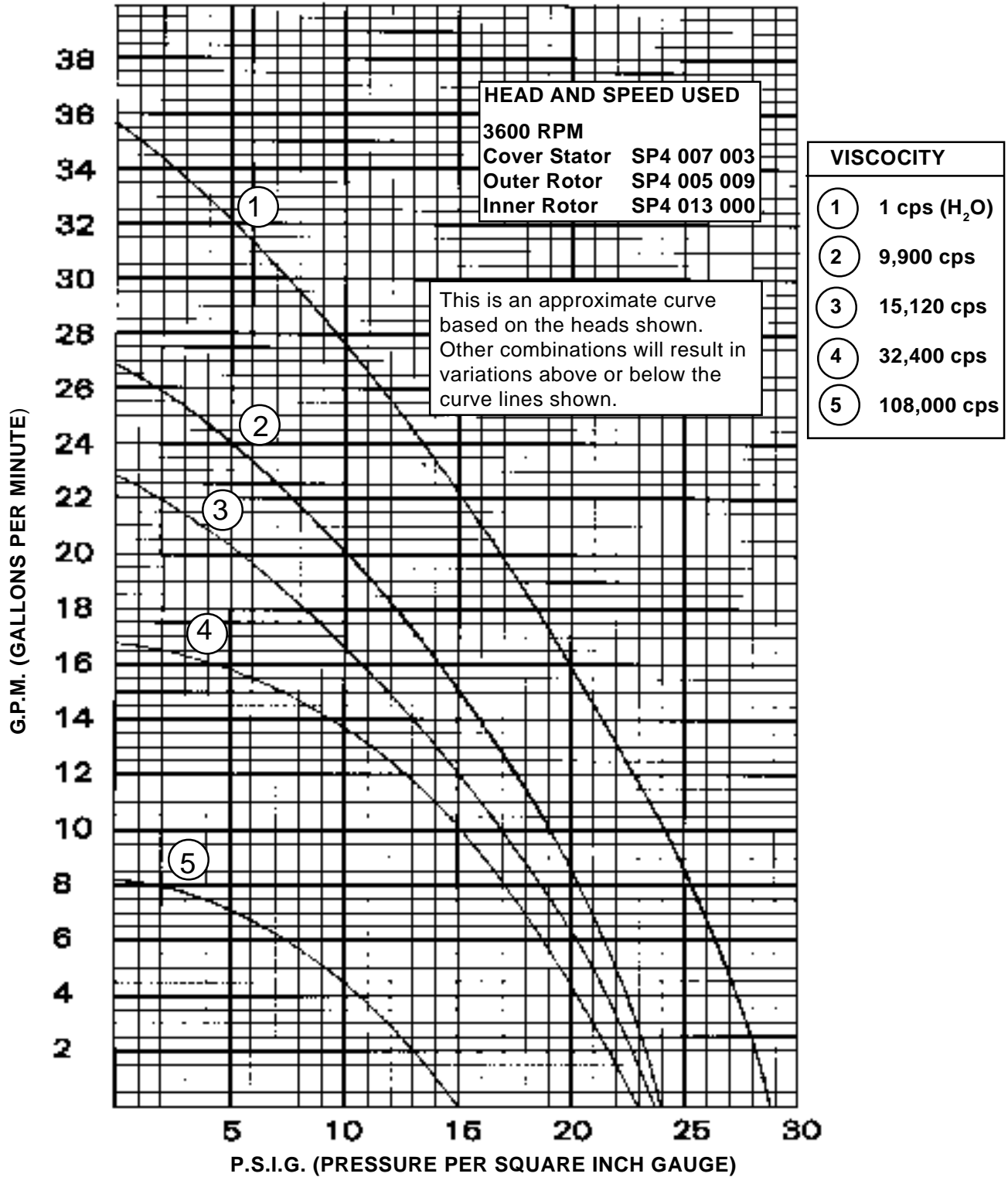

OPERATION

The following chart lists proven combinations of stators, rotors and speeds to process various products. Use this information as a guide to establish the best combination for your processing requirements.

NOTE: Part Numbers are stamped on all Stators and Rotors for easy identification/selection.

TYPE PRODUCT	PROCESS DESCRIPTION	HEADS			
		COVER STATOR	OUTER ROTOR	INNER ROTOR	SPEED RPM
Polyester Resin	Emulsify	SP4 007 001	SP4 005 009	SP4 012 001	5200
Shampoo	Reduce Viscosity	SP4 007 001	SP4 005 009	SP4 012 001	1350/5400
French Dressing	Emulsify	SP4 007 001	SP4 005 001	SP4 012 001	3600
Deodorant	Emulsify	SP4 007 001	SP4 005 008	SP4 012 001	1350/5400
Acidulated Soap Stock	Stabilize	SP4 007 001	SP4 005 008	SP4 012 001	5200
Orange Juice Concentrate	Blending	SP4 007 001	SP4 005 008	SP4 012 001	3600
Suntan Lotion	Stabilize Viscosity	SP4 007 001	SP4 005 008	SP4 012 001	3600
Medicated Pill Ointment	Blend and Smooth	SP4 007 001	SP4 005 008	SP4 012 001	3600
65 Brix/Orange Juice-sgl. str	Blending	SP4 007 001	SP4 005 008	SP4 012 001	3600
Sauces & Soups	Texturize	SP4 007 001	SP4 005 008	SP4 012 001	3600
Shortening Type Products	Texturize	SP4 007 001	SP4 005 008	SP4 012 001	3600
Titanium Dioxide	Dispersion	SP4 007 001	SP4 005 008	SP4 012 001	1350/5400
Dye Gum	Shearing/Blending	SP4 007 001	SP4 005 008	SP4 012 001	3600
Glycerin & Water Ointments	Mixing	SP4 007 001	SP4 005 008	SP4 012 001	1350/5400
Citrus Oil Emulsion and Orange Juice	Blend	SP4 007 001	SP4 005 008	SP4 012 001	3600
(Like Milk of Magnesia)	Particle Reduction	SP4 007 001	SP4 005 008	SP4 013 000	5200
Rerun Ice Cream	De-aerate	SP4 007 001	SP4 005 008	SP4 013 000	5200
Powdered Cheddar Cheese & Coconut Oil	Dispersion	SP4 007 001	SP4 005 008	SP4 013 000	5200
DyeDispersion		SP4 007 001	SP4 005 008	SP4 013 000	3600
Titanium Dioxide	Dispersion	SP4 007 001	SP4 005 008	SP4 013 000	3600
Dipilatory	Smooth	SP4 007 006	SP4 005 011	SP4 013 000	1350/5400
Chocolate	Dispersion	SP4 007 0S5	SP4 005 013	SP4 001 3S2	1800

OPERATION - continued

NOTE: Part Numbers are stamped on all Stators and Rotors for easy identification/selection.

More Shear Pump head combinations:

Liquid/Liquid Emulsions

1. Cover Stator Part No. SP4 007 001
2. Inner Rotor Part No. SP4 012 001
3. Outer Rotor Part No. SP4 005 009 Fine
Outer Rotor Part No. SP4 005 001 Medium

Liquid/Solids Dispersions

1. Cover Stator Part No. SP4 007 001
2. Inner Rotor Part No. SP4 013 000
3. Outer Rotor Part No. SP4 005 008 Fine
Outer Rotor Part No. SP4 005 001 Medium

Chopping - Dicing

1. Cover Stator Part No. SP4 007 S05
2. Inner Rotor NONE
3. Outer Rotor Part No. SP4 005 013

AVAILABLE HEAD COMPONENTS

Cover Stators

1. SP4 007 001 3 " Diameter 1/8" Slots (25)
1. SP4 007 003 3 " Diameter 1/4" Dia. Holes (16)
1. SP4 007 006 3 " Diameter 1/2" Dia. Holes (16)
1. SP4 007 009 3 " Diameter 1/4" Slots (24)
1. SP4 007 S05 2 " Diameter 3/4" Dia. Holes (8)

Inner Rotors - Blades

2. SP4 012 001 Inner Rotor 1/8" Slots (26)
2. SP4 012 005 Spacer (No Inner Rotor)
2. SP4 013 000 Chopper (Blade) Rotor 3" Diameter
2. SP4 013 S02 Chopper (Blade) Rotor 2-1/2" Dia.

AVAILABLE HEAD COMPONENTS

Outer Rotors

3. SP4 005 001 Medium Shear
1/4" Head Slots (12)
1/8" Shear Slots (26)
3. SP4 005 003 Medium Shear
1/4" Head Slots (12)
1/8" x 1-3/8 Lg. Shear Slots (24)
1/4" x 1/2 Lg. Reverse Slots (24)
3. SP4 005 008 Fine Impact
1/4" Head Slots (24)
1/8" Shear Slots (40)
3. SP4 005 009 Fine Shear
1/4" Head Slots (24)
1/8" Shear Slots (40)
3. SP4 005 011 Ultra Coarse Shear
1/4" Head Slots (12)
5/8" Shear Slots (13)
3. SP4 005 013 Ultra Coarse Shear-Pumpless
5/8" Radius Head
5/8" Shear Slots (13)
3. SP4 005 014 Medium Coarse Shear
1/4" Head Slots (24)
1/4" Shear Slots (24)

NOTE: VARIOUS SPEEDS AND VISCOSITIES WILL PRODUCE VARIOUS RESULTS AND OUTPUT.

NOTE: DO NOT exceed 150 PSI through Shear Pump when feeding with positive displacement pump.

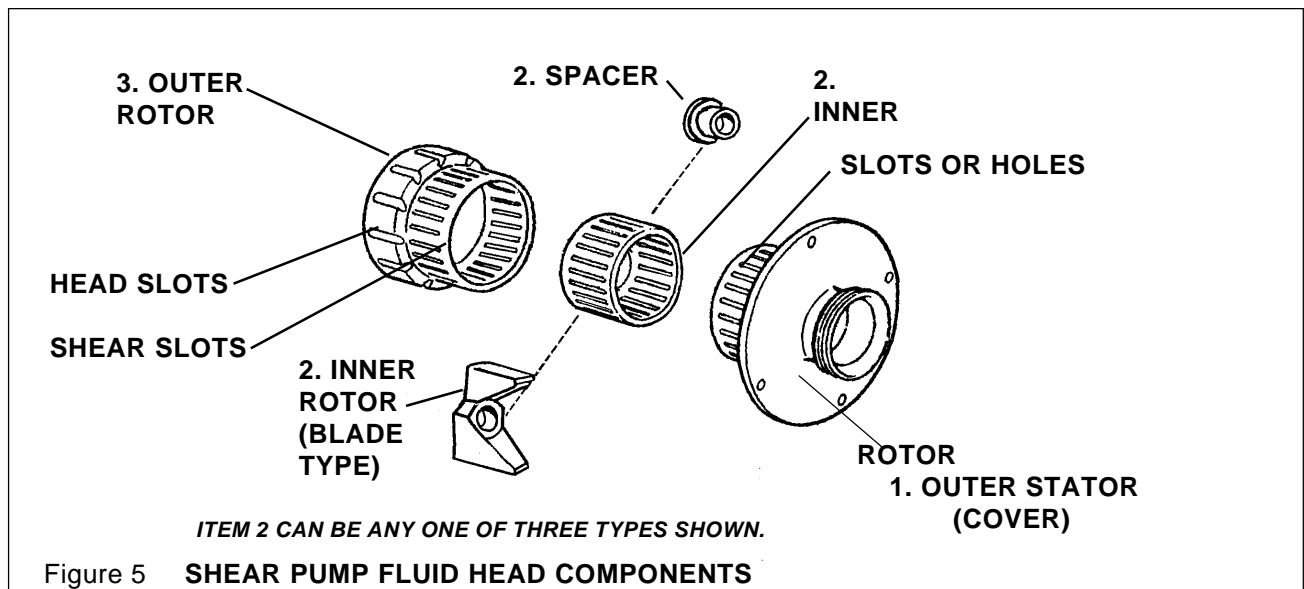

MAINTENANCE

The gear case contains approximately 2 quarts of oil. Check oil level at the pipe plug in the middle side of the case. *(Do not overfill.)*

Clean and maintain breather. Soak in solvent and blow out with low pressure air.

Besides a regular tool kit, the following tools and oil are required for pump maintenance:

T-HANDLE NUT WRENCH SP4 017 000
O-RING REMOVAL TOOL AD0 096 001
DTE BB MOBIL OIL (2 QUARTS) *OR EQUIVALENT*

PUMP TROUBLESHOOTING

No Discharge

- Pump not flooded (valve closed, supply blocked)
- Speed too low
- System head too high
- Suction lift higher than that for which pump is designed
- Wrong direction of rotation
- Air leak in the suction line

Insufficient Discharge

- Air leaks in suction
- Speed too low
- System head higher than anticipated
- Suction lift too high. Check with gauges. Check for clogged suction line.
- Not enough suction head
- Valve closed or restriction in discharge line.
- Wrong direction of rotation

Insufficient Pressure

- Speed too low
- System head less than anticipated
- Air or gas in liquid
- Mechanical defect
 - Wrong direction of rotation

Loss of Suction Following Period of Satisfactory Operation

- Leaky suction line
- Suction lift too high or insufficient NPSHA
- Air or gas in liquid
- Cover O-Ring defective

Overheating/Noise in Gear Case

- Bearing problem
(Because bearings control spacing of pump components. Immediate bearing replacement will avoid more serious pump component damage.)

Excessive Power Consumption

- Speed too high
- Insufficient seal flush
- System head higher than rating.
- Specific gravity or viscosity of liquid being pumped is too high
- Mechanical defects:
 - Shaft bent
 - Rotating element binds

Refer to these sections for proper maintenance instructions and information.

Page 15. **Disassembly** - Wet End

Page 16. **Assembly** - Wet End

Page 17. **Gear Case** Service

Page 18. **Pump Parts**

Page 19. **Pump Base Components**

MAINTENANCE

DISASSEMBLY OF WET END

If pump is completely installed in a system, the following procedures must be followed prior to disassembly:

1. **Exhaust** all product and turn off flushing to pump.
2. **Shut OFF** power and lock out or disconnect.
3. **Disconnect** piping from flanges and flushing..

WARNING
 To avoid electrocution,
 All power must be OFF and LOCKED OUT
 prior to servicing.

CAUTION
 Pump parts have sharp edges.
 To avoid cutting injury, wear gloves
 and handle parts carefully.

1. Remove the four wing nuts. (*Tap with soft hammer to loosen.*) (Figure 6)

NOTE: Do not hit threaded parts.

2. Carefully pull the stator cover straight back and remove from the body studs. (Figure 6)

3. Place the T-handle socket wrench into the inner rotor and TURN COUNTERCLOCKWISE to remove the hex nut. (*Tap with soft hammer to loosen nut.*) (Figure 7)

4. Remove the inner rotor, spacer or blade, by pulling straight off drive shaft. (Figure 7) (See Figure 5 for parts identification.)

5. Remove the outer rotor by pulling straight off drive shaft. (Figure 8)

6. Grasp the body and pull straight off the studs. (*Tap with soft hammer if body will not move freely.*)

Seal Replacement

1. Remove the seal carrier assembly by twisting slightly to release keeper tabs. (Figure 9)

2. If replacing seal carrier parts, remove the O-ring and the wave spring from the seal carrier.

3. Remove the O-ring and seal case pressed into the back of the body at the factory.

4. Remove the oil seal. (Figure 9)

5. In the front of the gear case, remove the seal seat (pull off). (Figure 10)

6. Remove the sleeve with the O-ring in it, then slide off the drive shaft O-ring. (Figure 10)

This sleeve O-ring assembly is required for Contained Flushing only.

7. Last, remove the slinger. (Figure 10)

This completes the wet end disassembly.
 (*See page 17 for gear case maintenance and service.*)

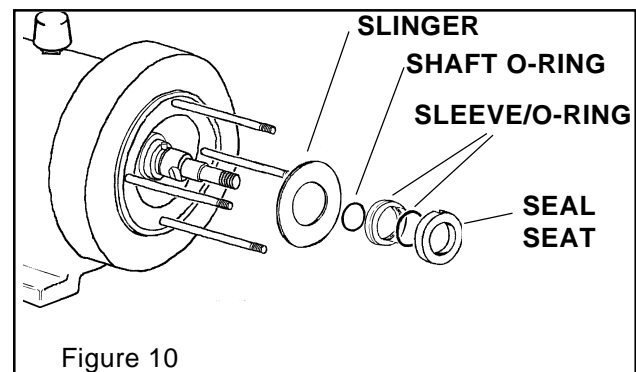
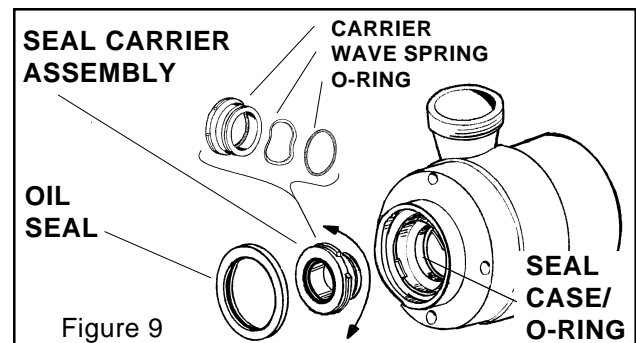
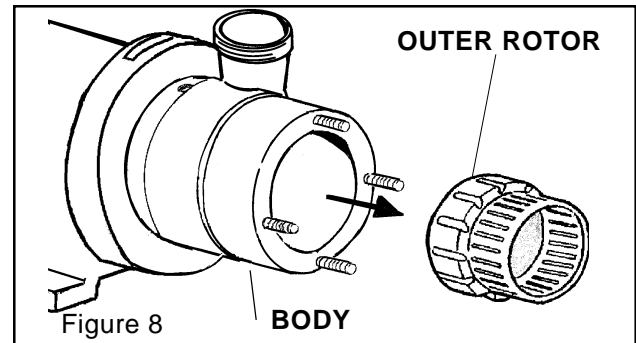
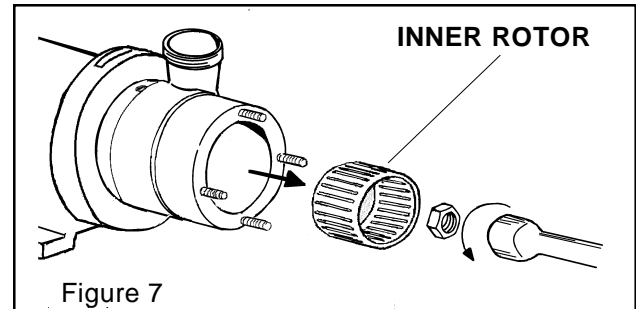
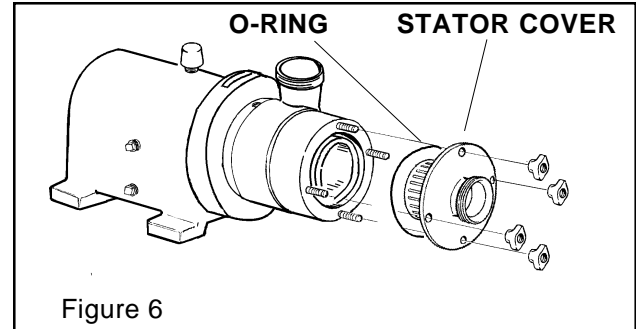

MAINTENANCE

ASSEMBLY OF WET END

CAUTION

Pump parts have sharp edges.
 To avoid cutting injury, wear gloves
 and handle parts carefully.

WARNING

To avoid electrocution,
 All power must be OFF and
 LOCKED OUT prior to servicing.

1. Install slinger onto shaft. Place the shaft O-ring into the groove on the shaft. Insert O-ring into flushing sleeve. Lubricate and install sleeve on shaft.

2. Install the seal seat onto the shaft, flush against the shoulder of the shaft. (Figure 11)
(NOTE: The drive pin located on the shaft near the shoulder must engage the drive slot located on the back of the seal seat.)

3. The seal case (BGT 305 101) and the O-ring (BGT 303 000) if removed, must be pressed into the body.

4. Install wave spring (BGT 304 000) and the O-ring (BGT 302 000) onto the seal carrier (BGT 306 120) as shown. (Figure 12)

5. Install assembled seal carrier into the seal case located in the body by lining up the "slots" on the carrier with the tabs in the seal case. Push in and twist the seal carrier to the left or right to lock it in place. (Figure 12)

6. Install the body over the (4) long studs with the discharge port located in correct position. (Figure 13)

7. Install outer rotor. A drive slot, located on its back face, must index into position and line up with the flats located on the drive shaft. (Figure 14)

8. Install inner rotor, spacer or blade rotor. The inner rotor is equipped with two drive lugs which are to be installed into the two mating holes located in the outer rotor.

9. Install "hex" nut onto the shaft and tighten securely with T-handle socket wrench (Clockwise). Tap handle with soft hammer to lock securely in place. (Figure 14)

10. Lubricate and install the cover O-ring into the groove inside the cover stator. (Figure 15)

11. Install the cover stator over the (4) studs and secure it in place with the (4) wing nuts. Tap wing nuts with soft hammer to secure.

The SHEAR pump will now turn over freely. Check this by inserting the T-handle socket wrench into the inlet port; engage it with the hex nut, and turn it **CLOCKWISE**.

(See Page 10 for **Seal Flush Connection**)

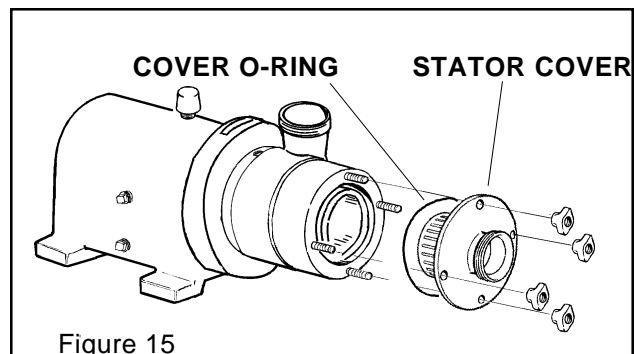
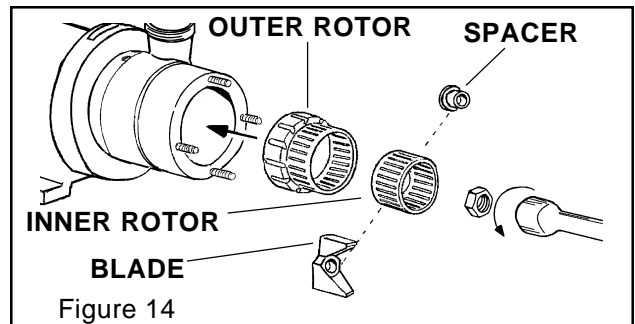
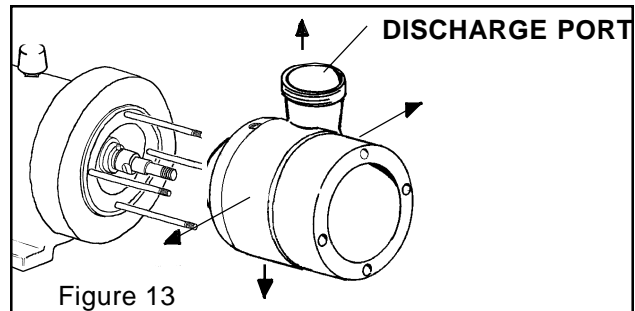
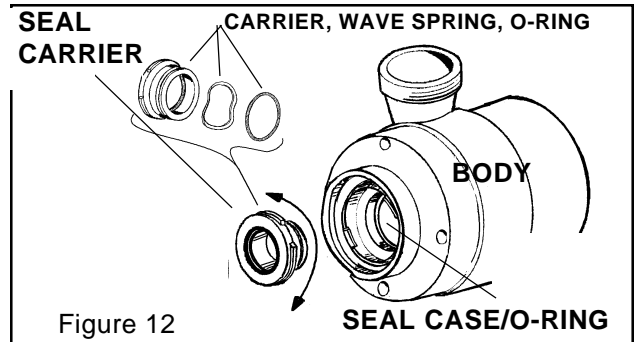
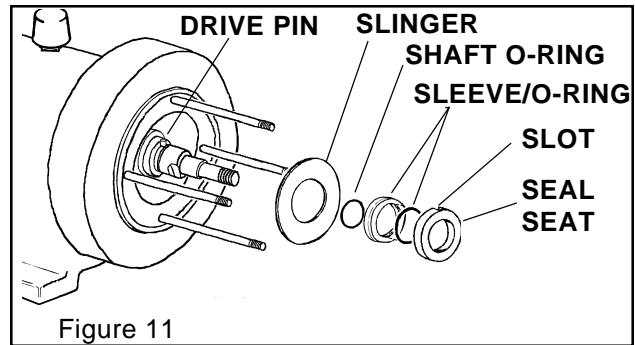

MAINTENANCE

GEAR CASE SERVICE

Tools required for seal and/or bearing replacement:

- Assorted hand tools including soft hammer.
- Bearing puller or press.
- Hook tool for seal removal.
- Spanner wrench for bearing retainer nut removal.
- Anti-seize and seal lubricating grease.
- 2 quarts DTE BB Mobil oil or equivalent.

CAUTION

Pump parts have sharp edges.
 To avoid cutting injury, wear gloves
 and handle parts carefully.

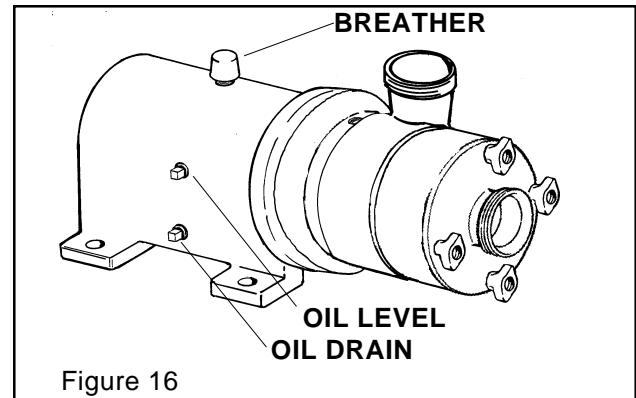

Figure 16

Service Preparation

1. **Shut OFF and lock out all power.**
2. **Remove all product and flushing from pump.**
3. **Disconnect all piping to pump.**
4. Remove pump anchor screws and slide pump off motor coupling.
5. Place pump on sturdy work surface.
6. **Disassemble wet end of pump completely.** (See Page 11 for Disassembly)
7. **Drain oil from gear case.** (Figure 16)

Front Seal Replacement (Figure 17)

1. Remove adapter plate. (Four (4) hex nuts)
2. Remove slinger. (Pull off)
3. Remove bearing retainer assembly (front seal inside) (Held in with 4 Socket Head Capscrews).
4. Note seal lip position and knock out old seal, place lubrication around new seal and press into bearing retainer. Replace gasket, if necessary. Lubricate seal lip and install bearing retainer and slinger.

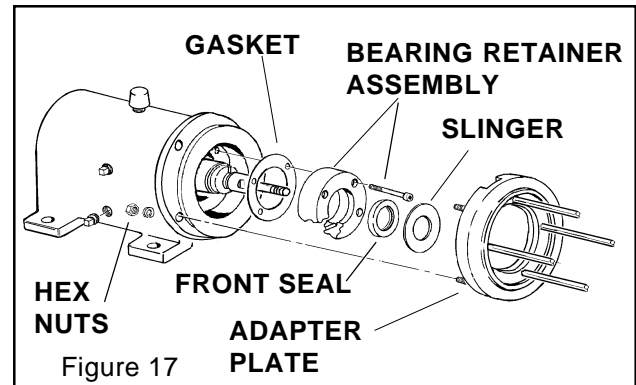

Figure 17

Rear Seal Replacement (Figure 18)

1. Pull rear oil seal off drive shaft with hooked tool.
2. Place tape over shaft keyway and install new seal. (Lubricate seal lip before sliding onto shaft).

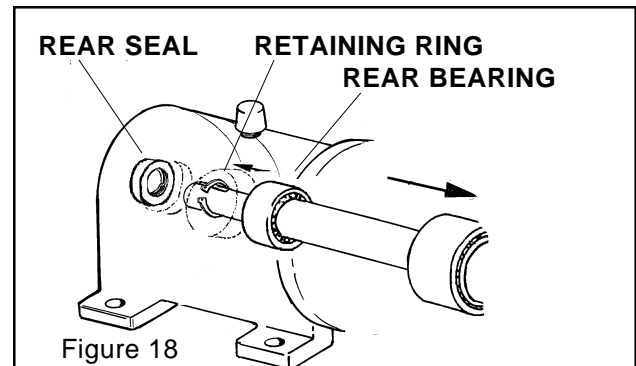

Figure 18

Bearing Replacement

1. Remove rear seal. Remove rear bearing retaining ring. Press drive shaft out through front of gear case (through rear bearing). (Figure 18)
 2. Remove bearing locknut from shaft and press front bearing off. (Figure 19)
 3. Press the rear bearing out of the front of gear case. (Figure 18)
- Clean and lubricate all parts thoroughly before reassembling. *Do not unwrap new bearings until ready to install.*
4. Lubricate inner races and press new bearings onto shaft. Tighten locknut on front bearing. (Figure 19)
 5. Lubricate outer races and press shaft assembly into case. Replace retaining ring and rear seal. (Figure 18)
 6. Replace front end assemblies. (Figure 17)
 7. Refill with 2 quarts Mobil DTE BB oil.

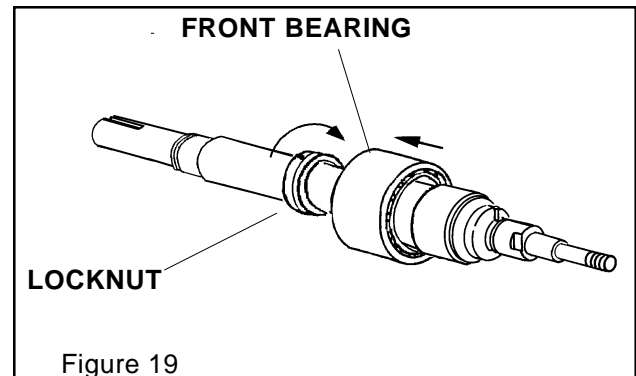

Figure 19

SHEAR PUMP WITH *FLUSHING

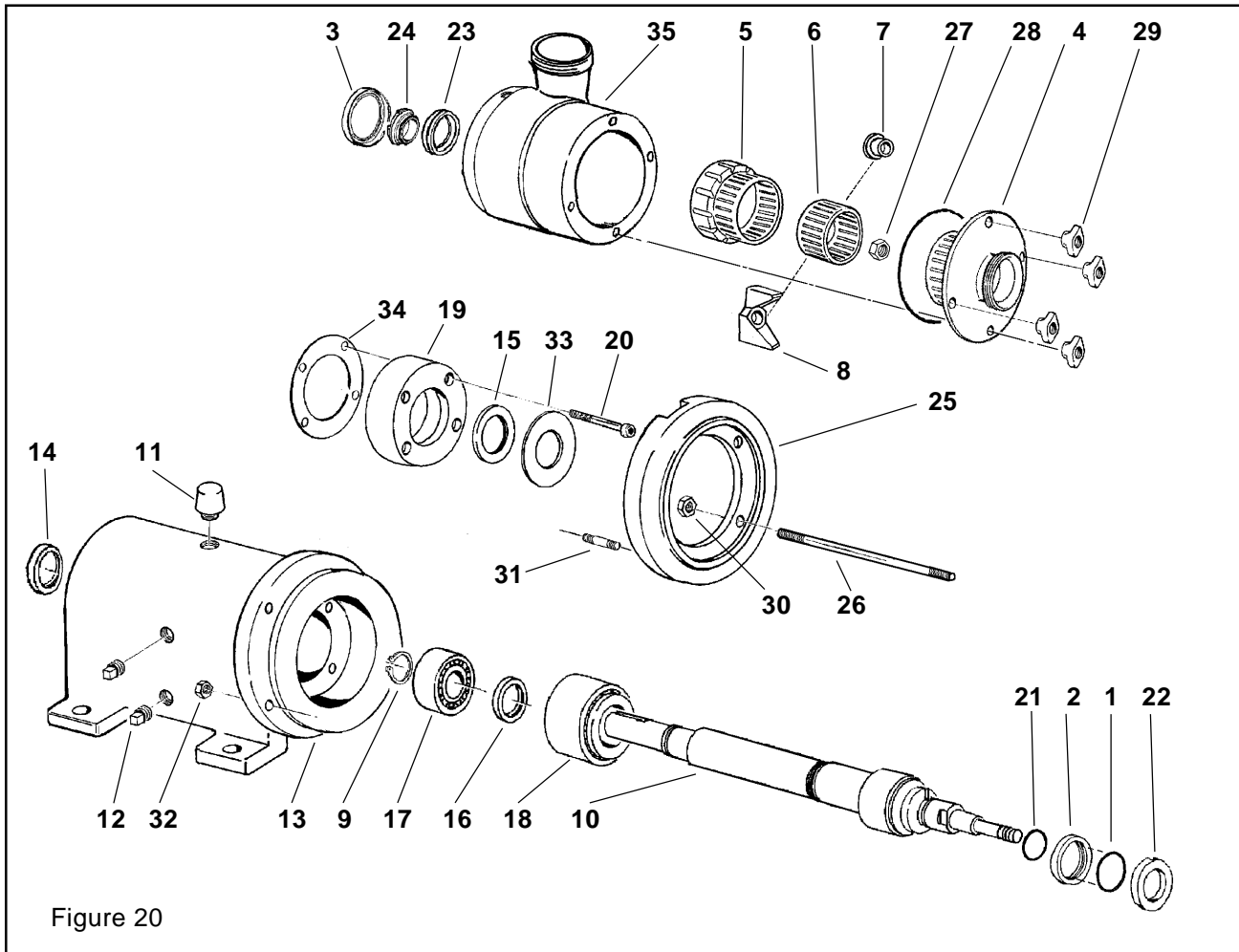

Figure 20

ITEM	PART NO.	QTY	DESCRIPTION
*1	B70 137 132	1	O-Ring, M.R. 38132, 366Y Buna
*2	SP4 098 000	1	Sleeve SS
*3	000 030 011	1	Oil Seal, .250 Shaft Dia. X .375
4	SP4 007 001	1	Cover Stator, Slots .12X 2
	SP4 007 003	1	Cover Stator, Holes .25D 16
	SP4 007 006	1	Cover Stator, Holes .50D 16
	SP4 007 S05	1	Cover Stator, Holes .75D 8
5	SP4 005 001	1	Rotor, Outer
	SP4 005 003	1	Rotor, Outer
	SP4 005 008	1	Rotor, Outer
	SP4 005 009	1	Rotor, Outer
	SP4 005 011	1	Rotor, Outer
6	SP4 012 001	1	Rotor, Inner
7	SP4 012 005	1	Spacer
8	SP4 013 000	1	Rotor Blade, Chopper 3"
	SP4 013 S02	1	Rotor Blade, Chopper 2.5"
9	BD0 087 R00	1	Ring, TRUARC
10	SP4 008 M00	1	Drive Shaft
11	STD 046 001	1	Filter Breather
12	STD 128 104	2	Pipe Plug, Sq/Hd 1/2-14 Cl.
13	OMS 005 000	1	Gear Case
14	OMS 030 000	1	Seal 1.500 I.D. X .562
15	OMS 030 100	1	Seal 2.375 I.D. X .375-.438
16	OMS 036 N00	1	Locknut
17	OMS 036 000	1	Bearing, No. 5308, Dble Row
18	OMS 036 300	1	Bearing, Roller

ITEM	PART NO.	QTY	DESCRIPTION
19	OMS 080 000	1	Bushing, Bearing Retainer
20	30-274	4	SHCS, 5/16-18 x 2.0" Stl 2
21	BD0 097 000	1	O-Ring, Shaft, Buna
22	BGT 014 000	1	Seal Seat, Ceramic
	BGT 014 011 Opt.		Seal Seat, SS Lapped Insert
23	BGT 305 101	1	Seal Case w/ O-Ring
24	BGT 306 120	1	Seal Assembly, Sil/Graph/Vit
	BGT 306 111 Opt.		Seal Assembly, Ceramic
	BGT 306 101 Opt.		Seal Assembly, Carbon
25	SP4 002 M00	1	Support, Adapter Plate
26	SP4 015 000	4	Stud, Inner
27	SP4 018 000	1	Hex Nut, Inner Rotor
28	SP4 031 000	1	O-Ring, 8245
29	SP4 032 000	4	Wing Nut
	36-83	4	Hex Nut, 3/8-16
30	36-70	4	Hex Nut, 1/2-13
31	OMS 011 000	4	Stud
32	36-70	4	Hex Nut, 1/2-13
33	OMS 045 000	1	Slinger, Zinc Plated
34	OMS 042 B00	1	Retainer Gasket
35	SP4 003 005	1	Body, Flushing
**	000 037 003	1	Key, 3/8 X 3/8 X 1-5/8
**	001 061 002	1	Nameplate, Sanitary Pump
**	001 061 013	1	Nameplate, Caution

* = Flushing Parts

** = Not Shown Opt. = Optional

SHEAR PUMP BASE ASSEMBLIES

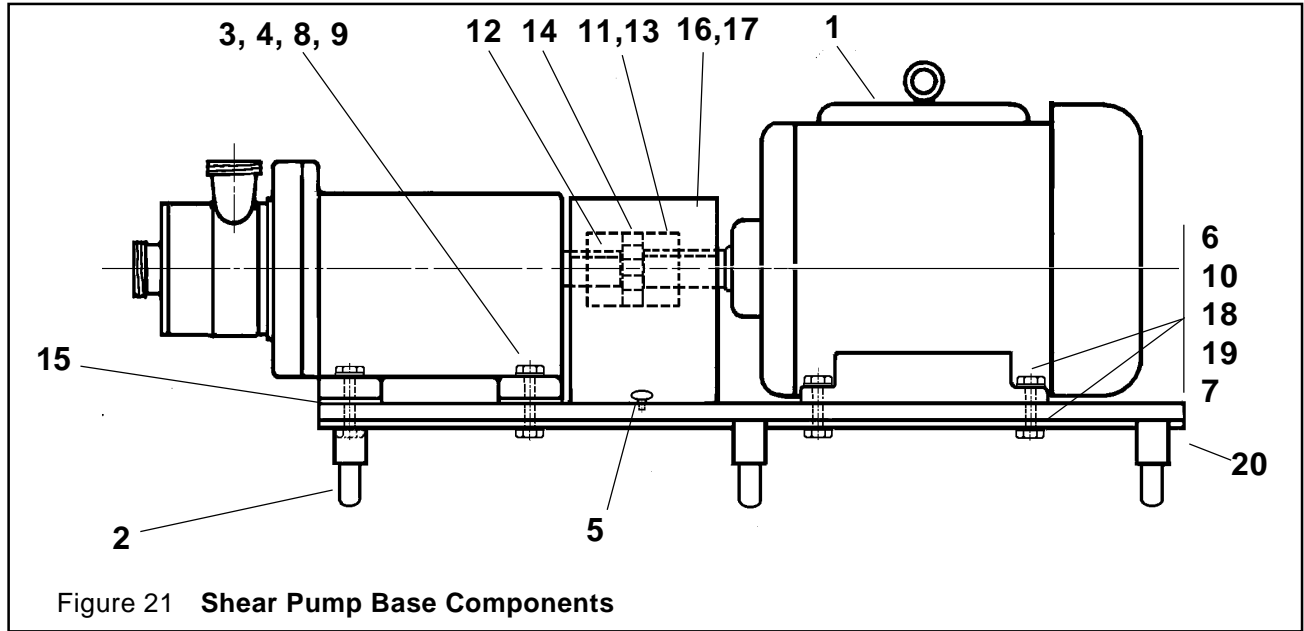

Figure 21 Shear Pump Base Components

PART NUMBER	DESCRIPTION	QTY, SIZE, MOTOR HP, PART NUMBER			
		A	B	C	D
1	Motor, 3600 RPM	10HP	15HP	20HP	25HP
2	ACC 156 000 Ball Foot, Adjustable, 3"	6	6	6	6
3	GD0 013 000 Lockwasher, 3/8"	4	-	-	*
4	43-177 Lockwasher, 1/2"	8	8	8	*
5	30-133 Thumbscrew 1/4-20 x 1/2"	2	2	2	2
6	43-189 Flat Washer 3/8" Narrow	8	-	-	*
7	43-170 Flat Washer 1/2" ZP 2 Wide	12	12	12	*
8	30-352 Capscrew, Hex Hd 3/8-16	4	-	-	-
9	0C1 050 100 Hex Nut 3/8-16 SS	4	-	-	-
10	30-111 SHCS 1/2-13 x 2.0 Stl.	4	-	-	-
11	33136 Motor Coupling L110	1.375 DIA.	1.625" DIA.	1.625" DIA	-
12	33137 Pump Coupling L110	1.50" DIA.	1.50" DIA.	1.50" DIA.	1.50" DIA.
13	33138 Motor Coupling L110	-	-	-	1.625" DIA
14	33162 Coupling Cushion L110	1	1	1	1
15	ACC 110 000 Pump Shim 3" OD 13/16 ID .25	-	4	4	4
16	ACC 025 058 Coupling Guard	1	1	1	*
17	ACC 025 059 Coupling Guard	-	-	-	1
18	30-293 Hex Nut 1/2-13 ZP	-	4	4	*
19	36-70 Capscrew, 1/2-13 X 2.25"	-	8	8	*
20	35301 Base Plate Assembly	35301	35301	35301	35301

* Fastener type and quantity determined at assembly.

SHEAR PUMP BASE ASSEMBLY PACKAGE (DOES NOT INCLUDE MOTOR)

A	SP4 525 000	10HP 3600 RPM
B	SP4 525 001	15HP 3600 RPM
C	SP4 525 002	20HP 3600 RPM
D	SP4 525 003	25HP 3600 RPM

SP4 107100 MAINTENANCE KIT:

AD0 096 001 1	O-Ring Tool
SP4 019 000 1	T-Handle Nut Wrench

LUBRICANT AND PAINT:

000 142 301	Lubricant 3 OZ. Tube DC 732
000 140 001	Oil MOBIL DTE BB Bulk
000 165 000	Paint TNEMEC 104 Epoxy Sky Blue