



Scraped Surface Heat Exchangers

Votator[®] II, 4 x 120 & Votator[®] II Extra Heavy Duty



Votator® II, 4 x 120 & Votator® II Extra Heavy Duty Scraped Surface Heat Exchangers

For over seventy years, Votator® II Scraped Surface Heat Exchangers have been raising productivity, lowering production costs, and delivering more uniform end-products for a wide range of processing industries.

With Votator® units, companies in the food, chemical, petroleum, pharmaceutical, and allied industries have reduced labor costs substantially, because their reliance on expensive artisan skills has been minimized or eliminated.

Votator® II Scraped Surface Heat exchangers continue to replace many slow, inefficient batching operations with more uniform, controllable, and repeatable continuous processing. And, because of superior heat transfer performance and ability to handle a wide range of viscosities, they are still the clear choices over tubular or massive plate heat exchangers in viscous applications.

Votator® II Scraped Surface Heat Exchangers can be employed in the continuous, closed processing of virtually any pumpable fluid or slurry involving:

- Cooking
- Slush Freezing
- Cooling
- Crystallizing
- Mixing
- Plasticizing
- Gelling
- Polymerizing
- Heating
- Aseptic processing



How It Works

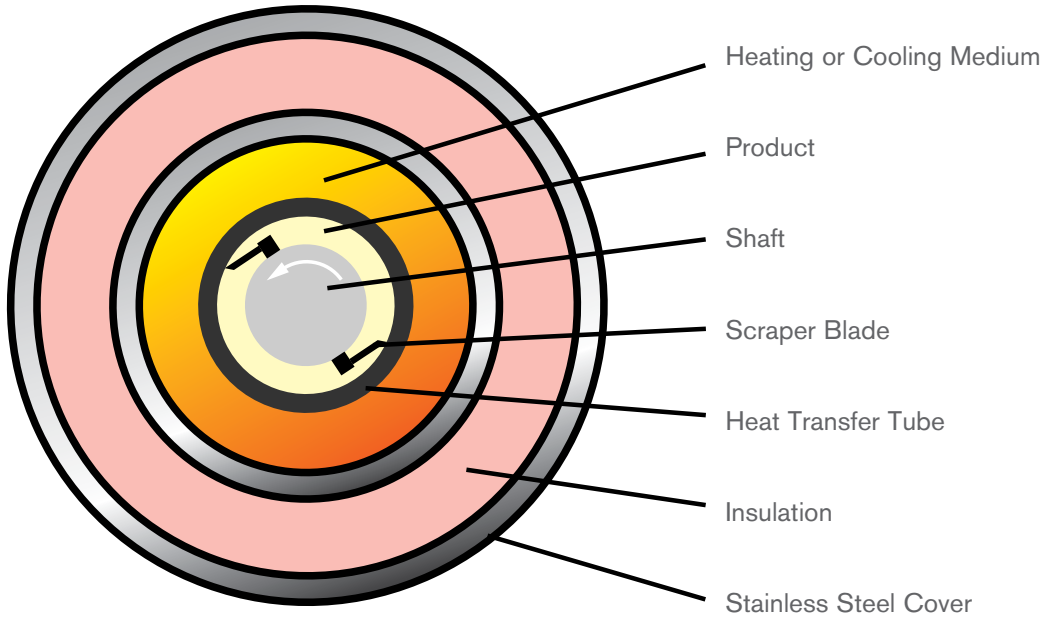

Votator's high efficiency and productivity results from a simple concept, heat or cool continuously moving product by providing a large heat transfer surface for a small amount of product in a confined space.

Inside every Votator®, a mutator shaft rotates within a tube. The product passes through an annulus formed by the shaft and heat transfer tube (light yellow). Heating or cooling medium flows in a jacket (orange). The unit is insulated (pink) to minimize energy loss and protect personnel. A stainless steel cover protects the insulation.

In operation, the rotating shaft has blades which continuously scrape product film from the heat transfer tube wall, thereby enhancing heat transfer, and agitating the product to produce a homogenous mixture.

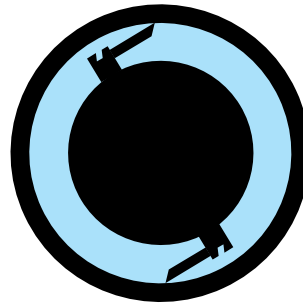

Concentric

For most applications the shaft is mounted in the center of the heat transfer tube, or CONCENTRIC.

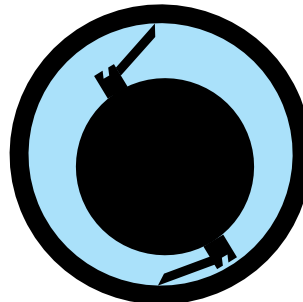

Eccentric

An off centered shaft mount or ECCENTRIC design is recommended for viscous and sticky products. This shaft arrangement increases product mixing, eliminates mass rotation, and reduces the mechanical heat load.

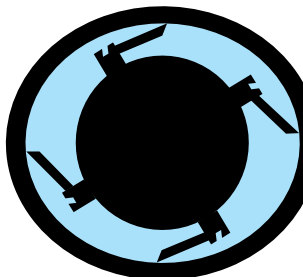

Oval Tubes

Oval tubes are used to process extremely viscous products. This design eliminates product channeling within the tube, it reduces mechanical heat by a double cam action of the scraper blades, and it balances the internal forces to prevent shaft deflection.

How Components Are Selected

Votator® Scraped Surface Heat Exchanger components are manufactured in a variety of configurations and materials so that each unit can be assembled to meet the specific processing requirement of each application.

All pressure elements are designed in accordance with the latest ASME code requirements and can be CE-PED certified.

Jacket – Votator® Scraped Surface Heat Exchangers can be jacketed for liquid, steam, or direct expansion refrigeration.

Heat Transfer Tube – Thermal conductivity and wall thickness are key design considerations in selecting heat transfer tubes. Tube wall thickness is precisely engineered to minimize heat transfer resistance while maximizing structural stability.

Pure nickel tubes provide high thermal conductivity. The inside of the tube is hard chrome plated, then honed and polished to a smooth finish for resistance to wear from scraper blades and abrasive products.

Stainless steel tubes specially designed for enhanced heat transfer are offered for acidic products and to provide flexibility in the use of cleaning agents for aseptic processing.

Scraper Blades – Votator® scraper blades are arranged on the shaft in staggered rows. The blades are held on the Votator® Scraped Surface Heat Exchanger shaft by strong, durable, specially designed “universal pins,” which are welded to the shaft. There are no threaded areas to cause product build-up and possible unsanitary conditions. These pins allow quick, easy blade removal and replacement. A variety of blade materials are available.

Seals – Years of experience led to development of the Votator® rotary mechanical seals. Seals are designed for easy assembly and maintenance, and for clean operation. Standard seal faces for best durability consist of hardened surfaces. Flexible seal parts are available in a variety of elastomers.

Votator® II double mechanical seals are designed with the capability to use steam or water seal flush, and all are suitable for aseptic processing.

Shaft – The amount of time the product is within the heat exchanger for a given rate is controlled by the volume of the unit.

Small-shaft heat exchangers provide a large annulus for longer residence time, they handle lumpy products and those having large particles. Large-shaft heat exchangers provide a smaller annulus for high velocity and turbulence with high heat transfer rates and short product residence time in the unit.

Drives – The drive for the Votator® Scraped Surface Heat Exchanger is selected to provide optimum performance in each individual application and thus assure that the product is vigorously agitated and continuously removed from the heat transfer wall. Votator® Scraped Surface Heat Exchangers are furnished with direct drive gear motors with horsepower selection for optimum performance for the specific application.

Shaft Mounting	4x120	Votator® II	Votator® Extra Heavy Duty
Concentric	X	X	X
Eccentric		X	X
Oval			X

Versatile In Applications



Heat Sensitive Products – Delicate products which are adversely affected by prolonged exposure to heat are effectively processed in Votator® II Scraped Surface Heat Exchangers.

The scraper blades prevent product from remaining on the heat transfer surface by continuously removing and renewing the film. Because only a small amount of product is exposed to heat for just a short time, burn-on is minimized or eliminated.



Viscous Products – Votator® II Scraped Surface Heat Exchangers process viscous products far more efficiently than conventional plate or tubular heat exchangers. Product film is continually scraped from the heat transfer wall to induce high heat transfer rates; constant agitation causes turbulent flow and more consistent heating or cooling; pressure drop is effectively controlled by the product annulus area; agitation eliminates stagnant areas and product build-up; and cleaning is easier.

Particulate-Laden Products – Products with particulates which tend to plug conventional heat exchangers are handled easily in Votator® II Scraped Surface Heat Exchangers, and the particulates maintain maximum product identify.

Crystallized Product – Products which crystallize are ideal candidates for Votator® II Scraped Surface Heat Exchanger processing. As product crystallizes on the heat transfer wall, the scraper blades remove it and keep the surface clean.



Food and Meat Processing – Votator® II Scraped Surface Heat Exchangers can serve the food and meat industries in an extensive variety of applications. Whether it's cooling, heating, sterilizing, crystallizing, freeze concentration, or processing a difficult-to-handle product, the Votator® II is able to meet the most exacting standards.

Aseptic Processing – Scraped surface heat exchangers from Waukesha Cherry-Burrell have many applications in aseptic processing, particularly those involving viscous and particulate-laden products.

Waukesha Cherry-Burrell has been a pioneer in the development of several types of aseptic processing systems. These systems sterilize food and other perishable products before they are sealed in pre-sterilized containers for distribution by non-refrigerated means.

Chemical Processing – the chemical, pharmaceutical, and petrochemical industries can employ Votator® II Scraped Surface Heat Exchangers in many processes, which can be grouped in four general categories.

1. Heating and cooling
2. Crystallization
3. Reaction control
4. Any of the above with aeration or mixing

Caramel, candy syrups, cheese, cheese whey, chocolate, creme centers, fondants, sandwich cremes, fudge, fat-water-protein, gelatin, freeze concentrates, icings, marshmallows, lard, peanut butter, lecithin, pie fillings, margarine, puddings, nougat, shortening, sauces, tomato products, sausage, aseptically processed products, hamburger, deboned poultry, deboned red meat.

Votator® 4x120 Scraped Surface Heat Exchangers

The 4 x 120 is a unique concentric heat exchanger designed for heating and cooling moderately viscous products. The heat transfer cylinder is 4 inches (102 mm) in diameter by 120 inches (3048 mm) long.

Features:

- All 316 stainless steel construction with high efficiency 0.083 stainless steel heat transfer tube or optional AL6XN tube
- Available with 9 ft² (0.84 m²) heat transfer area
- Horizontal units can be mounted side by side with up to 8 cylinders per frame or furnished loose for vertical mount
- All units suitable for steam or liquid media
- Mechanical seal with flush connection on drive end with sleeve bearing on non-driven end
- 3 and 5 horsepower (2.2 kW – 5.5 kW) gear drives with shaft speeds of 90 and 175 rpm; No couplings, belts or sheaves
- Product side pressure of 200 psig (14 bar) @ 365° F (185° C); Jacket pressure of 150 psig (10.5 bar) @ 365° F (185° C)
- 2.375 inch (60 mm) shaft diameter for particulates up to 0.75 inches (19 mm)
- 2 inch S-line product connections 1-1/2 FPT media connections
- Easy to field insulate after installation
- 3A and CE-SEP compliant

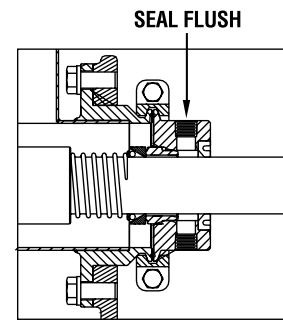

Drive end mechanical seal
(Ceramic or Graphitar)

Dimensional Data Model 4x120

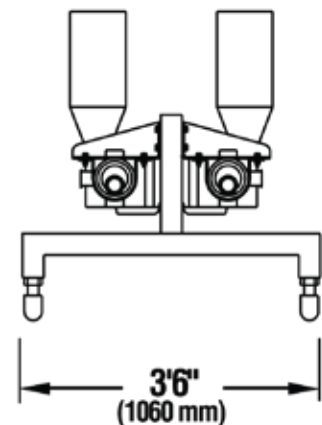
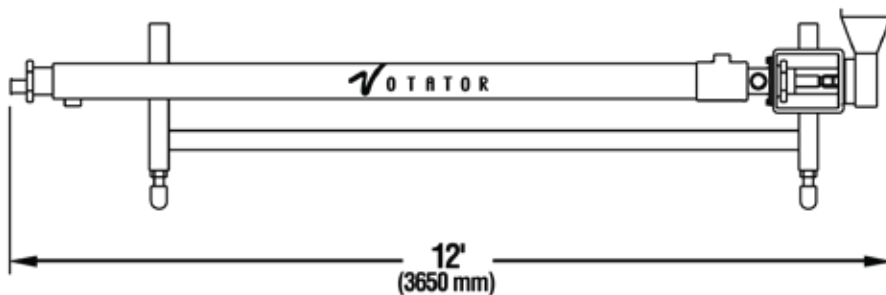

Votator® II Scraped Surface Heat Exchangers

The Votator® II is the newest design of scraped surface heat exchangers. It is a combination of design features from the proven Votator family, Thermutator Heat Exchangers, and new innovations resulting in a rugged, economical, and hygienic heat exchanger that can be used for heating and cooling products of a wide range of viscosities, including extremely thick and sticky products that require the cam action of the eccentric design.

Features:

- Can be mounted vertically or horizontally
- Sanitary appearance
- Minimum overall length
- USDA, CFIA, 3A and ASME design standard; CE-PED optional
- Tough 2" (50 mm) shaft spline
- Steam/ water or gravity /pumped liquid refrigerant jacket configurations
- Concentric or eccentric shaft mounting

Dimensional Data Model 6x72

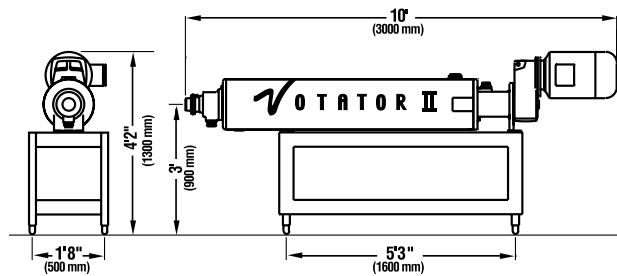

Process Matched:

- Drives From 7-1/2 TO 20 HP
- Wide range of output speeds
- Chrome plated nickel heat transfer tubes or 316 stainless steel tubes specially designed for enhanced heat transfer
- Stainless steel or plastic scraper blades
- Mutator shaft diameter based on fluid properties, 2-1/2", 4", 4-1/2", and 5-1/4" (63, 102, 114, and 133 mm)
- Single and double mechanical seals

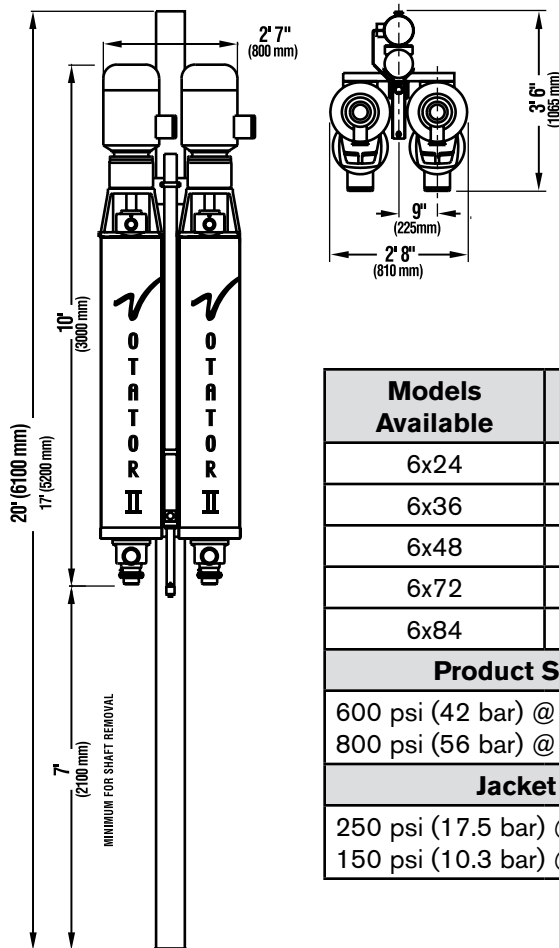

Easy to Maintain:

- Stainless steel exterior and stainless steel painted drive
- Open stainless steel mounting frame
- Boltless V-Lock heads for quick disassembly
- Splined mutator shaft removes in minutes
- Unique boltless blade mounting pins
- Gear motor drive - no couplings, belts or sheaves
- Heat transfer tube separate from media jacket. It has a reliable double O-Ring seal on each end and can be removed from the jacket in minutes without disturbing the media piping.

Models Available	Heat Transfer Area
6x24	3.0 ft ² (0.28 m ²)
6x36	4.2 ft ² (0.39 m ²)
6x48	6.0 ft ² (0.56 m ²)
6x72	9.0 ft ² (0.84 m ²)
6x84	11.0 ft ² (1.0 m ²)
Product Side Pressure	
600 psi (42 bar) @ 400° F (204° C) or 800 psi (56 bar) @ 400° F (204° C)	
Jacket Pressure	
250 psi (17.5 bar) @ 400° F (204° C) or 150 psi (10.3 bar) @ 400° F (204° C)	

Votator® II Easy to Maintain



1 After any servicing or inspection, the Votator® II reassembles quickly and easily: simply insert the self-aligning spline end of the mutator shaft into the hollow shaft in the gear motor drive. There is no complex shaft coupling, no sensitive stub shaft alignment, or vulnerable drive belts to service.



2 Boltless V-Lock heads let you remove the shaft for inspection or routine maintenance in minutes.



3 Scraper blades are secured to the mutator shaft by the Votator® II universal mounting pins, and are easily and quickly removed and replaced.

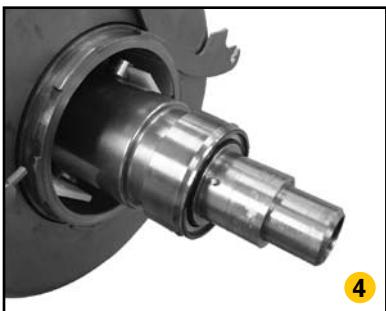

4 One-piece rotating seal body provides durability and simplifies maintenance.

5 And the seal spring is out of the product zone.

6 The heat transfer tube is bolted to the jacket assembly. The seal design for both ends features double O-Rings. The tube can be removed easily without disturbing or disconnecting the media piping.

7 Hydraulic lift mechanism guides the mutator shaft through its full range of travel.

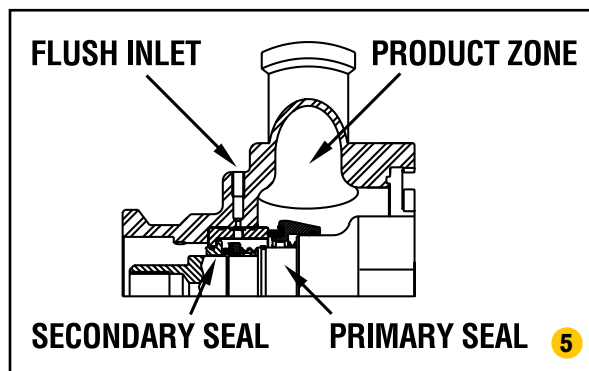
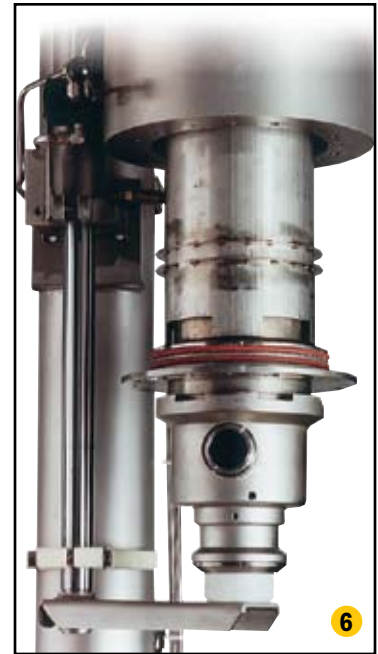

Votator® II Extra Heavy Duty Scraped Surface Heat Exchanger

The Votator® name carries with it the reputation of durability that is unequalled. The Extra Heavy Duty Votator® II is capable of heating and cooling products with viscosities in the 1,000,000 centipoise range. The units have high torque 17-4 PH stainless steel drive spline, can be equipped with direct drives with up to 30 horsepower, and are available with Concentric, Eccentric or Oval heat transfer tubes to provide optimum processing conditions for any product.

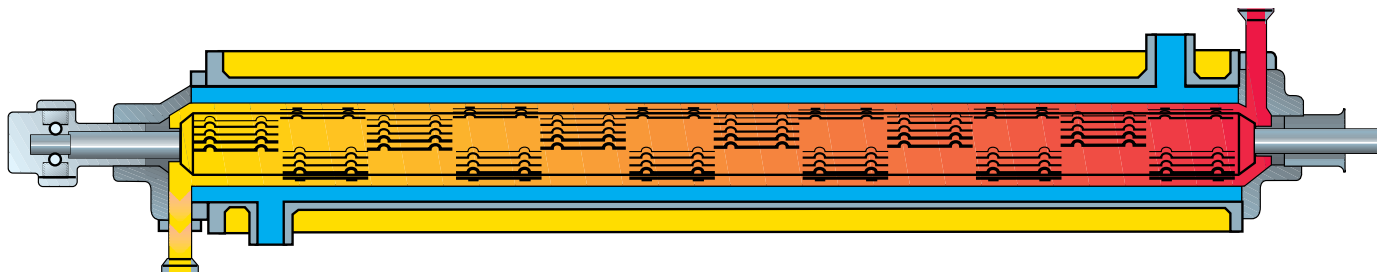

Features and Options

The Extra Heavy Duty (XHD) Scraped Surface Heat Exchanger is now available as a Votator II option. The Extra Heavy Duty option has a special heavy-duty roller bearing on the non-driven product head and a high torque 17-4 PH Stainless Steel spline on the driven end of the Mutator shaft. The motor pedestal is modified to use a larger gear drive with a 20, 25, or 30 Horsepower motor. Other mechanical features and most options are the same as the standard Votator® II.

- The overall dimensions of the unit and space requirements are the same as the Votator II.
- It has bayonet locking product heads without bolts.
- The integral Nord gear motor drive with a stainless steel mounting pedestal - without the traditional drive shaft and motor coupling - reduces the overall length or height of the unit by over 2 feet.
- It has a flange bolted heat transfer tube with a double O-Ring seal on each end, drastically reducing the maintenance time associated with servicing that component.
- The mechanical seal is the same design as the standard Votator® II and is available as a single or double seal.

Versatile Heat Transfer Systems

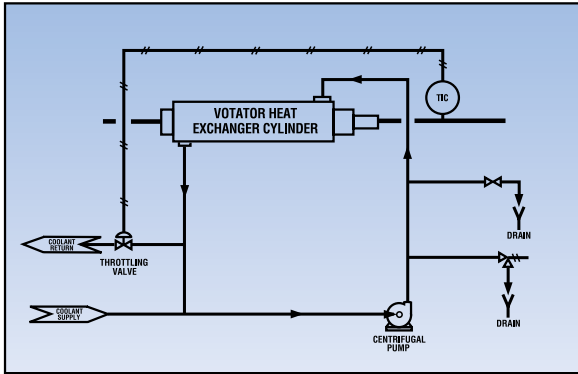

Brine Water Steam

Liquid / Steam Jacketing

When using a liquid heat transfer medium, it is necessary to maintain a high flow rate for optimum efficiency. This is accomplished by using a centrifugal pump to maintain a constant media flow. A controller monitors the product temperature out of the Votator® II heat exchanger and allows liquid media from the supply to be introduced into the loop as required.

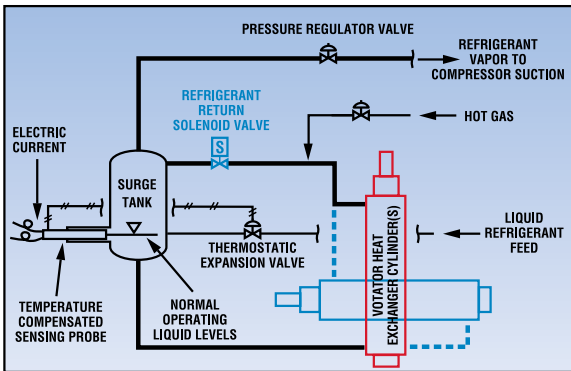

Gravity System

Gravity System

In the gravity refrigeration system, liquid refrigerant flows from a receiver in the compressor plant to a surge drum installed above the Votator® II or the Votator® II Extra Heavy Duty. A modulating thermostatically controlled expansion valve automatically maintains the correct refrigerant level in this vessel. Gravity forces the refrigerant into the cooling jacket, where product heat vaporizes a portion of the liquid and reduces the bulk density of the remainder. The flow of vapor and this density difference combine to create the classic “thermosyphon effect,” which forces liquid refrigerant to circulate from the surge drum to the cooler. A regulating valve controls the pressure in the surge drum and, consequently, the temperature of the refrigerant in the cooling cylinder. Make-up liquid enters through the level control and the entire cycle continues. Individual surge drums can be provided for each cooling cylinder or a single drum can be used for two cylinders.

The gravity system protects against freeze-up through an instantaneous current relay system. Optional hot gas controls also can be provided for freeze-up protection and to assist in removing refrigerant for pump down.

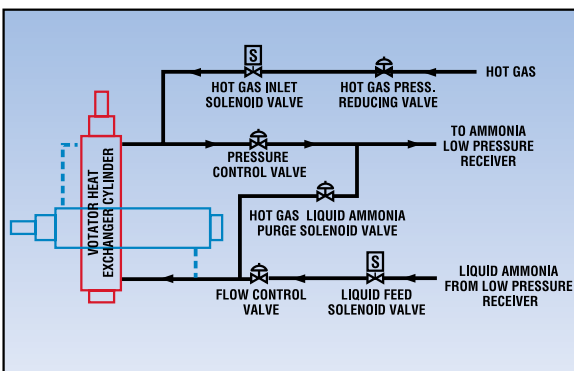

Liquid Overfeed Refrigeration System

Liquid Overfeed Refrigeration System

Liquid Overfeed (LOF) is available on the Votator® II and the Votator® II Extra Heavy Duty. It is a proven direct expansion concept in which only 25-35% of the liquid refrigerant flowing to the heat exchanger is actually vaporized. A large low pressure receiver replaces individual surge drums. This receiver, normally located in the compressor plant, is designed to separate the vapor from the circulated liquid. Waukesha Cherry-Burrell has designed many scraped surface heat exchangers for operating with Liquid Overfeed refrigeration. Overload protection against freeze-up is included and hot gas systems can be provided.

Votator® Shortening & Margarine Systems

Votator® technology pioneered continuous, controlled shortening and margarine production more than 70 years ago. All systems rely on the unique efficiency of Votator® Scraped Surface Heat Exchangers in achieving quick, consistent production of crystal nuclei. The super-cooled product is then plasticized for the desired crystal structure through controlled agitation and working in a Votator® agitated holding unit or it is held in a static rest unit to develop a more rigid structure.

Votator® systems can be furnished for various capacity requirements for bulk or bakery shortening, lard, and margarine formulations for stick, tub, and spreads, and Puff Pastry formulations. All systems are easy to install.

SLS Features

- Includes Votator® II SSHE
- All stainless steel construction
- Pre-piped assembly factory-tested before shipment
- Eductor permits injection of low pressure air or nitrogen
- High pressure feed pump has no mechanical seal
- Individual gear motor drives - no belts or sheaves
- Open mounting frames for easier cleaning
- Rotary joints for mutator shafts are standard
- Votator® extrusion valve assures correct product texture
- Reliable and efficient refrigeration controls

Options

- Manual or automatic control panels
- Shaft diameters for controlled residence time
- Tempered-water circulating systems for shaft rotary joints
- Process-matched refrigeration compressor systems
- Eccentric Votator® II shortening post coolers

Why do you think they call it "VOTATING"?

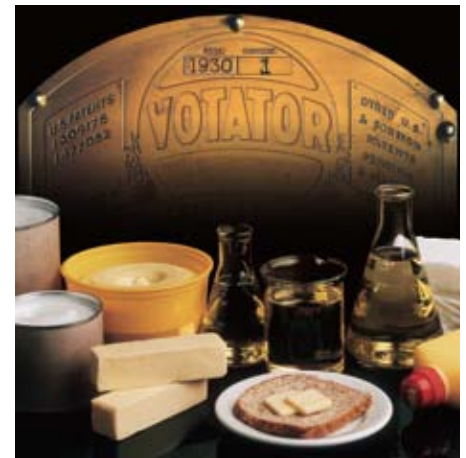

Margarine Models	Lbs/Hr	Kg/Hr
1M48	2300	1000
1M72	3500	1600
2M48	4600	2100
2M72	7000	3200
3M72	10500	4700
4M72	14000	6400

Shortening Models	Lbs/Hr	Kg/Hr
SLS61	3000	1300
SLS91	5000	2200
SLS182	10000	4500
SLS364	20000	9000

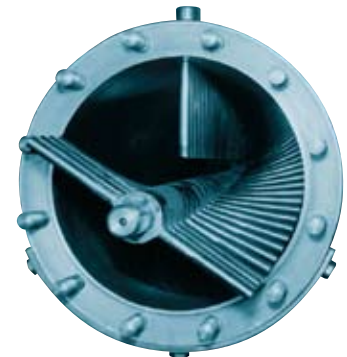

The Votator® Agitated Holding Unit consists of a tube, in which a motorized shaft with agitating pins revolves at a fixed speed; the unit prevents margarine from "setting," so it can deliver the soft product to tubs or bulk containers.

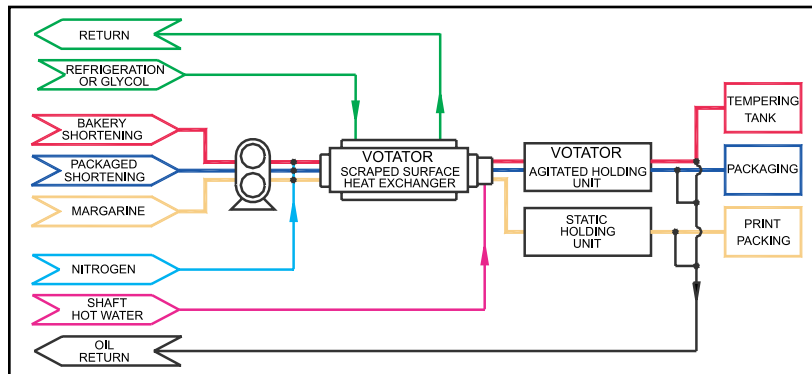

Votator® Scraped Surface Heat Exchangers



Vertical
Votator® II



Liquid or Steam Votator® II



Votator® 4 x 120



Votator® Process Systems



Liquid Overfeed Refrigeration Votator® II

SPX®

PROCESS EQUIPMENT

SPX Process Equipment
611 Sugar Creek Road
Delavan, WI 53115
Phone: (262)728-1900 or (800) 252-5200 Fax: (262) 728-4904 or (800) 252-5012
E-mail: wcb@spx.com

Packaging - Processing
Bid on Equipment
1-847-683-7720
www.bid-on-equipment.com

For more information about our worldwide locations, approvals, certifications, and local representatives, please visit www.spxpe.com.

SPX Corporation reserves the right to incorporate our latest design and material changes without notice or obligation.

Design features, materials of construction and dimensional data, as described in this bulletin, are provided for your information only and should not be relied upon unless confirmed in writing.