



Operation and Maintenance Manual DTL Blender



**Read and understand this manual
prior to installing, operating or servicing this equipment.**

Table of Contents

Waukesha Cherry-Burrell Warranty	4
Shipping Damage or Loss	4
Warranty Claim	4
Safety	5
Introduction	6
Description	6
Installation	7
Unpacking	7
Receiving and Inspection	7
Location and Installation	7
Piping	7
Maintenance	8
Cleaning	8
Disassembly for Cleaning	8
C.I.P. Cleaning	8
DTL Blender Disassembly	9
External Balanced Type D, F. Dg Seals:	9
Water Cooled Balanced Double Seal Type E:	9
Deflector and Stub Shaft Removal	10
Shaft and Motor Removal (Model WP3218MD)	10
Model WP2116MD Assembly	11
Model WP3218MD Assembly	11
Disassembly of the Butterfly Valve	12
Setting the Drive Collar	12
Blenders With D, F. Or DG Seals	12
Install the deflector on the shaft.	12
Setting The Drive Collar By Position	12
Blenders With E Seals	13
Care of Stainless Steel	14
Stainless Steel Corrosion	14
Alloy 88	14
Elastomer Seal Replacement Following Passivation	14
Troubleshooting	15

Waukesha Cherry-Burrell Warranty

Seller warrants its products to be free from defect in materials and workmanship for a period of one (1) year from the date of shipment. This warranty shall not apply to products which require repair or replacement due to normal wear and tear or to products which are subjected to accident, misuse or improper maintenance. This warranty extends only to the original Buyer. Products manufactured by others but furnished by Seller are exempted from this warranty and are limited to the original manufacturer's warranty.

Seller's sole obligation under this warranty shall be to repair or replace any products that Seller determines, in its discretion, to be defective. Seller reserves the right either to inspect the products in the field or to request their prepaid return to Seller. Seller shall not be responsible for any transportation charges, duty, taxes, freight, labor or other costs. The cost of removing and/or installing products which have been repaired or replaced shall be at Buyer's expense.

Seller expressly disclaims all other warranties, express or implied, including without limitation any warranty of merchantability of fitness for a particular purpose. The foregoing sets forth Seller's entire and exclusive liability, and Buyer's exclusive and sole remedy, for any claim of damages in connection with the sale of products. In no event shall Seller be liable for any special consequential incidental or indirect damages (including without limitation attorney's fees and expenses), nor shall Seller be liable for any loss of profit or material arising out of or relating to the sale or operation of the products based on contract, tort (including negligence), strict liability or otherwise.

Shipping Damage or Loss

If equipment is damaged or lost in transit, file a claim at once with the delivering carrier. The carrier has signed the Bill of Lading acknowledging that the shipment has been received from WCB in good condition. WCB is not responsible for the collection of claims or replacement of materials due to transit shortages or damages.

Warranty Claim

Warranty claims must have a **Returned Goods Authorization (RGA)** from the Seller before returns will be accepted.

Claims for shortages or other errors, exclusive of transit shortages or damages, must be made in writing to Seller within ten (10) days after delivery. Failure to give such notice shall constitute acceptance and waiver of all such claims by Buyer.

Safety

READ AND UNDERSTAND THIS MANUAL PRIOR TO INSTALLING, OPERATING OR SERVICING THIS EQUIPMENT

Waukesha Cherry-Burrell recommends users of our equipment and designs follow the latest Industrial Safety Standards. At a minimum, these should include the industrial safety requirements established by:

1. Occupational Safety and Health Administration (OSHA), Title 29 of the CFR
Section 1910.212- General Requirements for all Machines
2. National Fire Protection Association, ANSI/NFPA 79
ANSI/NFPA 79- Electrical Standards for Industrial Machinery
3. National Electrical Code, ANSI/NFPA 70
ANSI/NFPA 70- National Electrical Code
ANSI/NFPA 70E- Electrical Safety Requirement for Employee Workplaces
4. American National Standards Institute, Section B11

Attention: Servicing energized industrial equipment can be hazardous. Severe injury or death can result from electrical shock, burn, or unintended actuation of controlled equipment. Recommended practice is to disconnect and lockout industrial equipment from power sources, and release stored energy, if present. Refer to the National Fire Protection Association Standard No. NFPA70E, Part II and (as applicable) OSHA rules for Control of Hazardous Energy Sources (Lockout-Tagout) and OSHA Electrical Safety Related Work Practices, including procedural requirements for:

- Lockout-tagout
- Personnel qualifications and training requirements
- When it is not feasible to de-energize and lockout-tagout electrical circuits and equipment before working on or near exposed circuit parts

Locking and Interlocking Devices: These devices should be checked for proper working condition and capability of performing their intended functions. Make replacements only with the original manufacturer's renewal parts or kits. Adjust or repair in accordance with the manufacturer's instructions.

Periodic Inspection: Industrial equipment should be inspected periodically. Inspection intervals should be based on environmental and operating conditions and adjusted as indicated by experience. At a minimum, an initial inspection within 3 to 4 months after installation is recommended. Inspection of the electrical control systems should meet the recommendations as specified in the National Electrical Manufacturers Association (NEMA) Standard No. ICS 1.3, Preventative Maintenance of Industrial Control and Systems Equipment, for the general guidelines for setting-up a periodic maintenance program.

Replacement Equipment: Use only replacement parts and devices recommended by the manufacturer to maintain the integrity of the equipment. Make sure the parts are properly matched to the equipment series, model, serial number, and revision level of the equipment.

Warnings and cautions are provided in this manual to help avoid serious injury and/or possible damage to equipment:



DANGER: marked with a stop sign.
Immediate hazards which *WILL* result in severe personal injury or death.



WARNING: marked with a warning triangle.
Hazards or unsafe practices which *COULD* result in severe personal injury or death.



CAUTION: marked with a warning triangle.
Hazards or unsafe practices which *COULD* result in minor personal injury or product or property damage.

Introduction

Description

The DTL Blender is designed to introduce a dry material to a liquid and through a mechanical action provide a blended end product for a process.

The DTL Blender has two sections, the dry material section and the liquid material section.

The DTL Blender model WP3218MD is mounted on a base plate. The blender is driven by belts located under the base plate. These belts are driven by the drive motor mounted next to the blender assembly. A electrically controlled butterfly valve and control panel are standard equipment on model WP3218MD. The control panel may be mounted directly to the DTL Blender base, or a remote location.

The DTL Blender model WP2116MD is mounted, on a base plate, with the drive motor mounted to the underside of the base plate. The motor shaft which extends through the base plate into the stub shaft secured to the impeller. Material flow is controlled with a hand operated butterfly valve. Optional electrically or pneumatically controlled valves are also available.

All piping connections are made with quick couple S-Clamps. The support legs are adjustable for leveling of the blender during installation.

Installation

Unpacking

The model WP3218MD DTL Blender is packed in two separate shipping containers, the hopper is in one crate, the Blender and its components are packaged in another crate. The blender and drive motor are mounted to the base plate which is secured to a wood pallet.

The adjusting legs and clamps are in a bag packed with the blender.

The control box and the control valve are packaged in a separate carton.

Model WP2116MD DTL Blender is shipped in one container.

Receiving and Inspection

WCB equipment is run tested or inspected prior to shipment. When leaving the factory, it is well crated for normal transportation procedures. WCB cannot, however, guarantee safe arrival. Therefore, upon receipt of this equipment, check the received items against the packing list for damage or missing parts. Check the packing material thoroughly for small parts.

Visually inspect for damage or loss. Damage or loss should be reported immediately to the delivery carrier while present. Following the immediate notification of the lost or damaged parts, a detailed description including quantity, description of the loss or damage, and a cash value should be claimed against the carrier with respect to the guidelines set forth by the responsible carrier's policies. WCB's responsibility terminates F.O.B. point of manufacture unless otherwise specified per the General Terms and Conditions of Sale as published by WCB and amended from time to time. Contact WCB Order Services if shipping information is required for handling claims.

In the case of damage or loss to the equipment, WCB may perform three major functions:

Manufacturer Function - WCB manufactures quality equipment and stands behind the WCB Standard Warranty. Refer to the Standard Warranty.

Location and Installation

For best performance locate DTL Blender unit within 3 feet of the liquid source and in a position where the supply piping will be short and direct with a minimum number of elbows and fittings. When installing the unit consider accessibility for future cleaning and inspection.

To install the WP2116MD model a minimum space of 20" x 20" will be needed to accommodate the basic unit. For the WP3218MD model a minimum space of 32" x 47" will be needed. Install the adjustable legs in the base of the unit and position the blender in the area it will be used. Turn each adjusting leg with a wrench until the unit is level.

An auxiliary pump is required to supply the liquid to the blender.

Attach the supply and discharge piping. Be sure supply and discharge piping is properly supported to avoid strain on the blender casing.

The inlet connection on the model WP3218MD is 1-1/2" tube O.D. and the outlet on the impeller casing is 2" tube O.D. Be sure the inlet and outlet tubes are correctly positioned.

Piping

All piping is to be supplied and installed by the purchaser. Piping must be well supported near the unit and in line with connection fittings so that no strain is put on the fittings. The inlet piping should be short and follow a direct route. Elbows should not be used at the inlet. The use of elbows increases friction resulting in head loss and cavitation in the blender reducing performance, as well as increasing noise, vibration and damage to equipment. Whenever practical the diameter of the piping at the inlet should be increased in size. An eccentric tapered reducer, should be used in place of a straight concentric tapered reducer to help direct the flow into the offset tee to minimize turbulence. (For more information regarding reducers refer to Waukesha Fittings Catalog)

Maintenance

The DTL Blenders are relatively maintenance free, requiring normal cleaning and inspection to ensure optimum performance.

Cleaning



DANGER: ALWAYS turn off the electrical power supply and Lock Out, using a locking device for which only the person doing the work has the key, before performing service or maintenance.



WARNING: Hydrochloric acid, even with inhibitors added, is not recommended for cleaning stainless. (Inhibitors are specific compounds that are added to cleaning chemicals to diminish their corrosive effect on metals. Most inhibitors are proprietary, and recommendations for their use are available from the supplier).

It is necessary to disassemble all of the parts of the DTL Blender except the drive motor, for cleaning and sanitizing.

Disassembly for Cleaning

1. Disconnect the suction and discharge piping.
2. Remove the clamps securing the hopper to the blender.
3. Remove the clamps securing the butterfly valve end connections.
4. Disassemble the valve. "DTL Blender Disassembly" on page 9.
5. Remove each of the clamps and blender tubes in a top down sequence until all that remains is the impeller casing.
6. Grasp the impeller casing firmly in both hands and pull the casing up and off of the adaptor ring.
7. After disassembling the unit, rinse all parts with lukewarm water 100 F until all traces of ingredient and product are gone.
8. Brush the unit and all parts with a general purpose powered alkaline cleaning solution. Follow manufacturer's recommendations.
9. Immediately rinse the unit and parts with lukewarm water 100 F until all the detergent has been removed.

10. Rinse with hot water to facilitate quick drying and to eliminate water spotting.
11. Drain parts and allow them to air dry.
12. Inspect O-ring seals, and replace if necessary.
13. Before assembling the unit, apply sanitary lubricant to gaskets.

C.I.P. Cleaning

If the DTL Blender is to be cleaned-in-place, the butterfly valve must be removed and cleaned separately. See "Disassembly of the Butterfly Valve" on page 12. In addition the dry ingredients inlet adaptor tube must be capped off.

NOTE: The impeller casing and backplate are separated by a gasket. Do not attempt to separate the two sections by inserting a tool and prying them apart. This could result in damage to the machined surfaces of the adaptor ring and the gasket. A firm tug on the casing will separate the casing from the unit.

Remove the screen from inside of the impeller casing. To clean the impeller and backplate, remove the bolt securing the impeller to the shaft. Lift the washer and impeller off of the shaft.

Clean all of the disassembled blender components. "Care of Stainless Steel" on page 14.

If during the cleaning process you notice any damaged or worn parts replace them before reassembling the unit.

Reassemble the blender using the reverse order of disassembly.

DTL Blender Disassembly

It is recommended that periodic inspection of all parts of the DTL Blender be made to prevent malfunctions caused by worn or broken parts.

The following disassembly procedures cover the WP2116MD and WP3218MD models. Portions of the disassembly are identical for all models, but where differences occur the procedure for each model will be indicated.

NOTE: *Disassembly varies depending on the type of seal used. There are four types of seals: D, F, DG, and E.*



DANGER: *ALWAYS turn off the electrical power supply and Lock Out, using a locking device for which only the person doing the work has the key, before performing service or maintenance.*

1. Disconnect the suction and discharge piping.
2. Loosen the wing nut on the clamp, securing the hopper to the blender, until tension on the clamp saddle is relieved.
3. Open the clamp and remove the hopper and gasket.
4. Disconnect the clamp securing the control valve. Hold the valve while loosening the clamp, to prevent the valve from falling.
5. For repair and service of the butterfly valve on your blender see "Disassembly of the Butterfly Valve" on page 12
6. Remove the clamps on the top flange of the inlet adapter, and lift the diffuser and suction tube out of the inlet adapter.
7. Remove the clamp securing the inlet adapter to the impeller casing and remove the adapter and gasket.
8. Remove the large clamp securing the impeller casing to the backplate. Grasp the impeller casing firmly in both hands and pull the casing straight up and off of the backplate.



CAUTION: *Do not use a tool to pry the casing off of the backplate. Any object inserted between the casing and gasket could cause damage to the gasket and casing sealing surface, resulting in a leak after reassembly.*

9. Using a suitable wrench remove the bolt securing the impeller to the stub shaft. Remove the washer and impeller.

At this point, disassembly will vary, depending on the type of seal the blender has refer to the following procedures specific to your seal arrangement.

External Balanced Type D, F, Dg Seals:

1. Rotate the backplate until the pins in the plate clear the adapter pins.
2. Remove the backplate.
3. Carefully inspect the backplate, gasket, and impeller casing for nicks, scratches or signs of wear.



CAUTION: *Use caution, when handling the backplate to avoid damage to the surfaces around the opening for the carbon seal.*

- On DO models inspect the clamped-in seat for damage.
 - On F models remove the water flush piping.
4. Remove the carbon seal, O-ring seal, cup, spring, and drive collar.

Water Cooled Balanced Double Seal Type E:

1. Disconnect the water inlet and outlet from the stuffing box.
2. Remove the four screws that retain the follower to the stuffing box.
3. Slide the stuffing box and backplate assembly off of the shaft.
4. Remove the inboard carbon seal, seal O-ring, cup and the seal spring from the shaft.

Deflector and Stub Shaft Removal

1. Loosen the two set screws and remove the drive collar. The remaining carbon seal, seal O-ring, cup and the follower may now be removed from the shaft.
2. When removing the drive motor from the base plate, place a suitable block beneath the motor and turn the adjustable legs until the motor rests firmly on the block.
3. To remove deflector, lift straight off.
4. Remove the four nuts, bolts, and lock washers securing the motor to the base plate.
5. With the motor resting on the blocks, lift the base plate off of the motor, leaving the stub shaft attached to the motor.
6. Loosen the two setscrews securing the stub shaft to the motor armature shaft.
7. Remove the stub shaft by prying beneath it with a flat bar.
8. Examine the stub shaft sealing surface for nicks, or scratches which can cause excessive O-ring seal wear or leakage.
9. To remove the adaptor ring and spacers from the blender base, set the base on its side.
10. Remove the six socket head screws in the bottom of the base. While removing the socket head screws hold the adaptor to prevent it from falling.
11. Remove the adjustable legs from the blender base. Inspect the O-rings for damage.
12. To assemble see assembly procedures in this manuals for your particular model.

Shaft and Motor Removal (Model WP3218MD)

When removing the drive components, it is necessary to tip the entire blender and base on its side, with the motor end toward the floor. To ease the lifting of the unit remove all of the components possible before tipping.

1. Loosen the mounting bolts securing the drive motor to the base. The bolt holes are elongated to permit belt adjustment.
2. Slide the motor toward the blender and remove the drive belts.

NOTE: When replacing drive belts allow 3/4" deflection (slack).

3. Remove the three bolts securing the blender pulley. Use the same three bolts as forcing screws and thread them into the forcing holes, finger tight.
4. Turn each bolt an equal amount, alternating bolts until the pulley releases from the bushing.
5. Remove the forcing screws and remove the pulley.
6. Slide the tapered bushing from the shaft.
7. Loosen the setscrews securing the collar to the shaft and remove the deflector collar.
8. Loosen the six capscrews securing the adapter ring spacers. Hold the adapter ring to prevent it from falling.

9. Remove the capscrews and remove the adapter and spacers.
10. Set the blender down on its legs.
11. Remove the four capscrews securing the bearing housing to the base plate.
12. Grasp the bearing housing firmly in both hands, and lift it out of the blender base.
13. Remove the retaining ring and press the shaft out of the housing.
14. Using puller, remove the bearing from the shaft and remove the other bearing from the housing.
15. Inspect the shaft sealing surface for nicks or scratches.
16. Inspect all of the components for cracks and distortion. Inspect the adjusting legs for worn threads and damaged O-rings.
17. Replace any worn or damaged components.

NOTE: The two bearings in the bearing housing are sealed and lifetime lubricated. If either of the bearings are worn or damaged make certain they are replaced with exactly the same type of bearings, and replaced as a set.

Model WP2116MD Assembly

1. Install the adjusting legs into the base.
2. Install the ring adapter onto the base plate, place the base plate on top of the motor and install the motor.
3. Place the motor mounting screws (4) in position. Attach the nuts and washers, but do not tighten them securely at this time. The motor must remain loose enough to allow alignment of the motor stub shaft in the backplate.
4. Align the setscrew in the stub shaft with the key on the motor armature and slide the stub shaft down.
5. Place the backplate over the stub shaft and position the impeller on the shaft. Approximately 1/16 inch clearance should be between the backplate and the impeller. The setscrews on the stub shaft may now be tightened securely.
6. Remove the impeller and observe the position of the stub shaft in the backplate. If the stub shaft is not centered in the backplate, move the motor in the proper direction.
7. When the stub shaft is centrally located in the backplate, tighten the motor mounting screws (4) securely.
8. See "Setting the Drive Collar" on page 12
9. Assemble the impeller, retainer, mounting bolt, and casing gasket.
10. Place the impeller casing firmly on the backplate and seal the two together with the large clamp.
11. Assemble the remaining tubes and seals securing each section with the proper size clamps.

***NOTE:** For correct positioning of the inlet adapter, refer to the exploded view pages for appropriate models in the parts section of this manual*

12. Install the control valve and the hopper.
13. Connect all the suction and discharge piping.

Model WP3218MD Assembly

1. Install the bearing housing on top of the base plate.
2. Tip the blender on end and install the adapter ring.
3. Install the blender pulley key and bushing.
4. Place the pulley in position and be certain to use the correct mounting holes for the bolts securing the pulley; make sure that both pulleys are horizontally aligned.
5. Draw the pulley tight with the mounting bolts by alternately tightening each bolt a small amount until all three bolts are tight.
6. Place the drive belts on the motor pulley and the blender pulley. It may be necessary to move the motor toward the blender housing to place the belts on the pulleys.
7. Adjust the belts by moving the drive motor away from the blender housing until 3/4 inch of slack remains in the belts.
8. Secure the motor.
9. See "Setting the Drive Collar" on page 12
10. Assemble the impeller, retainer, mounting bolt, and casing gasket.
11. Place the impeller casing firmly on the backplate and seal the two together with the large clamp.
12. Assemble the remaining tubes and seals securing each section with the proper size clamps.

***NOTE:** For correct positioning of the inlet adapter, refer to the exploded view pages for appropriate models in the parts section of this manual.*

Disassembly of the Butterfly Valve

In the event that repair or replacement becomes necessary, the following procedures are suggested:

1. Drain and flush the piping surrounding the valve.
2. To remove handle, remove the socket head capscrew found at the top of the valve handle with the proper sized allen wrench.
3. Remove the nuts and capscrews.
4. Separate the valve body halves.
5. Set the butterfly disc to the open position.
6. Squeeze the seal until oval shaped, then slide the short end of the stem from the seal.

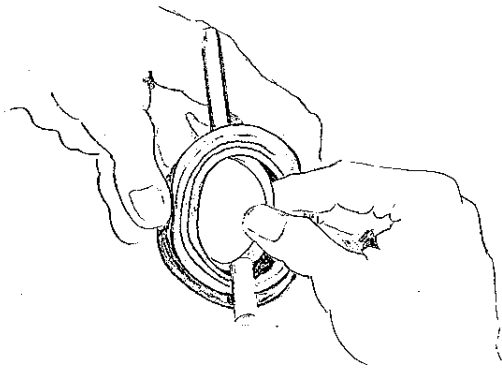

Figure 1 Valve Gasket Removal

7. Pinch the disc between the thumb and forefinger, and pull the long end of the stem from the seal.
8. Check for and replace a cracked or worn seal, stem and disc, or screw threads.

Reverse this procedure for assembly.

Setting the Drive Collar

Blenders With D, F, Or DG Seals

Install the deflector on the shaft.

When the drive collar has been removed or the carbon seal has been replaced, the drive collar must be positioned on the shaft by one of two following methods:

Setting The Drive Collar By Measurement

1. Install the backplate, gasket, and casing.
2. Install and tighten casing clamp. At a location behind the backplate scribe a mark on the shaft. See Figure 2 and Figure 3.
3. Remove casing clamp, casing, and backplate.
4. Slide the drive collar onto the shaft.
5. Locate drive collar in relation to the scribe mark as shown in dimension A and secure to the shaft with the set screws. Drive collar location is critical.
6. Install the seal spring, seal cup, seal O-ring and carbon onto the shaft.

Setting The Drive Collar By Position

1. Assemble the spring seal cup, O-ring seal, and carbon seal onto the drive collar.

NOTE: Take care that the spring does not rest on the tab that is bent back. A portion of the spring is offset to provide clearance for this tab.

NOTE: Ensure that pin on drive collar is in line with slot on cup. Install this assembly as a unit on the shaft.

2. Install the backplate and casing.
3. Install and tighten the casing clamp.
4. Install the backplate and casing.
5. Install and tighten the casing clamp.
6. Slide the drive collar and seal assembly toward the backplate until the nose of the drive collar pushes the O-ring and carbon seal tight against the backplate.
7. Slide the drive collar away from the backplate 1/32" and secure the drive collar in this location with the set screws.

Blenders With E Seals

1. Install the backplate, gasket, and casing.
2. Install and tighten casing clamp. At a location behind the backplate scribe a mark on the shaft. See Figure C.
3. Remove casing clamp, casing, and backplate.
4. Slide the follower, one carbon seal, one seal O-ring, one seal cup, and drive collar onto the shaft.
5. Locate drive collar in relation to the scribe mark as shown in Figure C and secure to the shaft with the set screws.

NOTE: Drive collar location is critical.

6. Install the seal spring, seal cup, seal O-ring and carbon onto the shaft. Be sure the spring is seated in each cup and the drive ear on each seal cup is not in alignment with the drive pins on the drive collar.
7. Slide the stuffing box and backplate assembly over the shaft and seal parts.
8. Secure the follower to the stuffing box using four screws.

NOTE: All Seals: With backplate and casing installed, and casing clamp tightened, the blender shaft should rotate freely by hand.

If excessive effort is required to rotate the shaft, check to be sure that all components are properly installed, and that the drive collar is properly positioned.

9. Assemble seal guard and tighten nut.

Type E: attach the water inlet and outlet to the stuffing box.

After setting instructions have been completed, return to the assembly instructions for your configuration on preceding pages.

Table 1: Dimensions chart for Figure 2, Figure 3, Figure 4

Model A	Dimensions
F2116	23/64
F3218	23/64

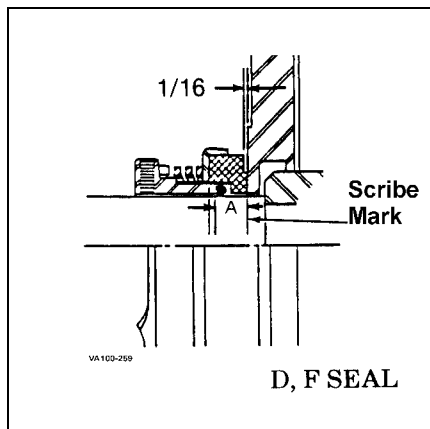

Figure 2 D,F Seals

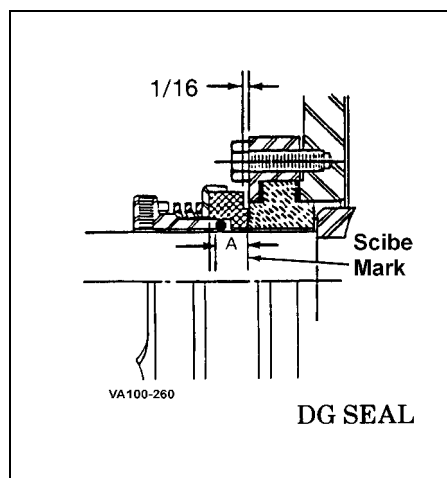

Figure 3 DG Seal

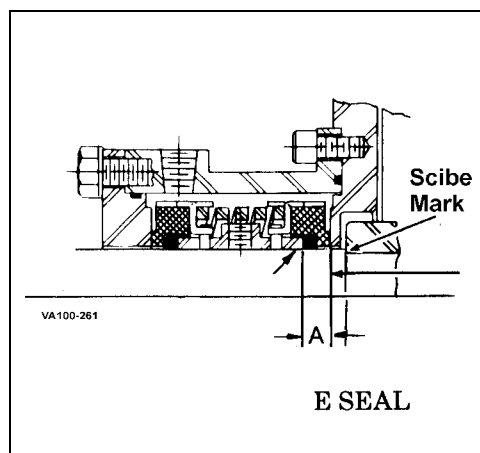

Figure 4 E Seal

Care of Stainless Steel

Stainless Steel Corrosion

Corrosion resistance is greatest when a layer of oxide film is formed on the surface of stainless steel. If film is disturbed or destroyed, stainless steel becomes much less resistant to corrosion and may rust, pit or crack.

Corrosion pitting, rusting and stress cracks may occur due to chemical attack. Use only cleaning chemicals specified by a reputable chemical manufacturer for use with 300 series stainless steel. Do not use excessive concentrations, temperatures or exposure times. Avoid contact with highly corrosive acids such as hydrofluoric, hydrochloric or sulfuric. Also avoid prolonged contact with chloride-containing chemicals, especially in presence of acid. If chlorine-based sanitizers are used, such as sodium hypochlorite (bleach), do not exceed concentrations of 150 ppm available chlorine, do not exceed contact time of 20 minutes, and do not exceed temperatures of 104°F (40°C).

Corrosion discoloration, deposits or pitting may occur under product deposits or under gaskets. Keep surfaces clean, including those under gaskets or in grooves or tight corners. Clean immediately after use. Do not allow equipment to set idle, exposed to air with accumulated foreign material on the surface.

Corrosion pitting may occur when stray electrical currents come in contact with moist stainless steel. Ensure all electrical devices connected to the equipment are correctly grounded.

Alloy 88

Waukesha Alloy 88 is the standard rotor material for Universal I, Universal II, Universal Lobe, Universal 420/520 and 5000 Series Rotary PD pumps. This alloy was developed specifically for corrosion resistance and close operating clearance requirements of high performance rotary positive displacement pumps. Alloy 88 is a nickel based, corrosion-resistant, non-galling or seizing material. The ASTM designation is A494 Grade CY5SnBiM (UNS N26055), and the material is listed in the 3-A Sanitary Standards as acceptable for product contact surfaces.

The above properties make Alloy 88 the ideal material for Waukesha stainless steel PD pumps. The non-galling rotors permit close operating clearances in the liquid end. This provides low slip and minimum shear damage. The rotors will not gall or seize if they come in contact with the body or cover during operation.

The corrosion resistance of Alloy 88 is approximately equal to AISI 300 Series Stainless Steel. However, Alloy 88 has limited resistance to certain aggressive chemicals that may be commonly used in contact with AISI 300 Series Stainless Steel.

Do not use Alloy 88 in contact with nitric acid. Nitric acid is commonly used to passivate new installations of stainless steel equipment. Do not allow nitric acid based passivation chemicals to contact Alloy 88 rotors. Remove the rotors during passivation and use a separate pump to circulate the passivation chemicals. Also, if nitric acid-based CIP cleaning chemicals are used, remove the rotors prior to CIP cleaning and clean them separately by hand in a mild detergent.

If you have questions regarding other aggressive chemicals, please contact Waukesha Cherry-Burrell Application Engineering for assistance.

Elastomer Seal Replacement Following Passivation

Passivation chemicals can damage product contact areas of WCB equipment. Elastomers (rubber components) are most likely to be affected. Always inspect all elastomer seals after passivation is completed. Replace any seals showing signs of chemical attack. Indications may include swelling, cracks, loss of elasticity or any other noticeable changes when compared with new components.

Troubleshooting

The following chart is intended as a guide to help correct most of your DTL Blender problems. Should problems arise where solutions listed in the chart below do not solve the situation, cavitation may be the problem. Symptoms of cavitation, such as noisy operation, insufficient discharge and vibration result when the auxiliary pump or the suction tube are not properly installed. If these conditions are present, check the system and re-evaluate the application. If assistance is required, contact Waukesha Cherry-Burrell Customer Service

PROBLEM	POSSIBLE CAUSE	SUGGESTED ACTION
1. No Suction	Wrong supply pump or lack of discharge pump	Verify that pumps are sized correctly for your application. Contact Waukesha Cherry-Burrell if you require assistance
	Leak on suction side of the supply pump	Tighten all clamps, fittings - replace worn out gaskets
	Carbon seal is worn	Replace carbon seal on blender and/or supply pump
	Wrong direction of rotation	Reverse a three phase motor by switching any of the three power leads at the motor or controller.
	Inlet port on wrong side	Remove inlet adapter housing and relocate so it is correctly positioned as shown on the exploded view pages.
	Splashing in the suction throat off the DTL Blender.	High Flow - oversized supply pump, see 1.a., above, see 1.d., above
	High % of solids	See 3
	High temperature	Reduce temperature below 140° F.
2. Insufficient blending	High % of solids with screen in discharge	Remove screen casing
	No liquids	Check supply pump
	Product too viscous, or discharge head too great	Add discharge pump
3. Excessive power consumption	High % of solids with screen in head	Remove screen in head
	High % of solids	Install discharge pump on discharge end of the Blender
4. Not enough liquid on discharge	Impeller diameter too small for duty	Contact Waukesha Cherry-Burrell Customer service for proper pump sizing
	Discharge head too high	The blender must be on the same level or below the main liquid supply
	Wrong direction of rotation	Check motor wiring and installation
	Pump not primed	Check liquid supply and liquid supply piping

PROBLEM	POSSIBLE CAUSE	SUGGESTED ACTION
	Speed too slow (low voltage, wrong frequency, wrong motor)	Check motor wiring and installation
	Suction or discharge plugged or closed	Check suction and discharge and remove any foreign materials
5. Motor Overload	Discharge head too low allowing pump to delivery too much liquid	Reposition discharge or blender to reduce output allowance
	High % of solids with screen in head	Remove screen in head
	High % of solids	Install discharge pump on discharge end of the Blender
	Impeller diameter too large for duty	Contact Waukesha Cherry-Burrell Customer service for proper pump sizing
	Liquid heavier or more viscous than rating.	Contact Waukesha Cherry-Burrell Customer service for proper pump sizing
	Electrical supply, voltage or frequency incorrect.	Check motor manufacturer specifications and wiring information.
	Mechanical abnormality in pump:	
	Impeller interference	Check for foreign material and remove if found
	Seal binding	Disassemble pump and verify proper assembly of pump
	Defective motor.	Contact Waukesha Cherry-Burrell Customer service
	Faulty electrical connections.	Check motor manufacturer specifications and wiring information.
Overload heaters too small for motor.	Check motor manufacturer specifications and wiring information.	

PROBLEM	POSSIBLE CAUSE	SUGGESTED ACTION
6. Vibration/Noise	Starved suction	Increase Net Positive Suction Head
	Starved suction -Supply line too long; too small or blocked	Adjust supply as needed
	liquid too hot or too viscous	Check supplied liquids fall within set operating parameters.
	Impeller shaft loose or bent	Check impeller shaft and replace if necessary
	Worn motor bearings	Replace bearings
	Pump not level	Level pump
	Foreign material in pump	Disassemble pump and remove foreign material
	Piping not properly supported	Check Installation Section in this manual for information on proper piping support
7. Rapid Seal Wear	Incorrect impeller shaft location; excessive spring loading	Check spring loading and impeller alignment
	Abrasive product	Contact Waukesha Cherry-Burrell Customer service for additional seal options
	Loose impeller shaft	Check impeller shaft and replace if necessary
	Water hammer	Adjust process to reduce air in the system
	Prolonged "Dry" running	Increase liquid supply or disengage pump when not in use
8. Seal Leaks	Gasket damaged or worn	Replace gasket
	Seal not installed correctly	Disassemble and install seal correctly
	Inlet/Outlet connection loose or gasket missing	Check connections for gasket and proper tightness
	Casing clamp loose	Tighten casing clamp

Puriti DTL Blender Model F2116MD

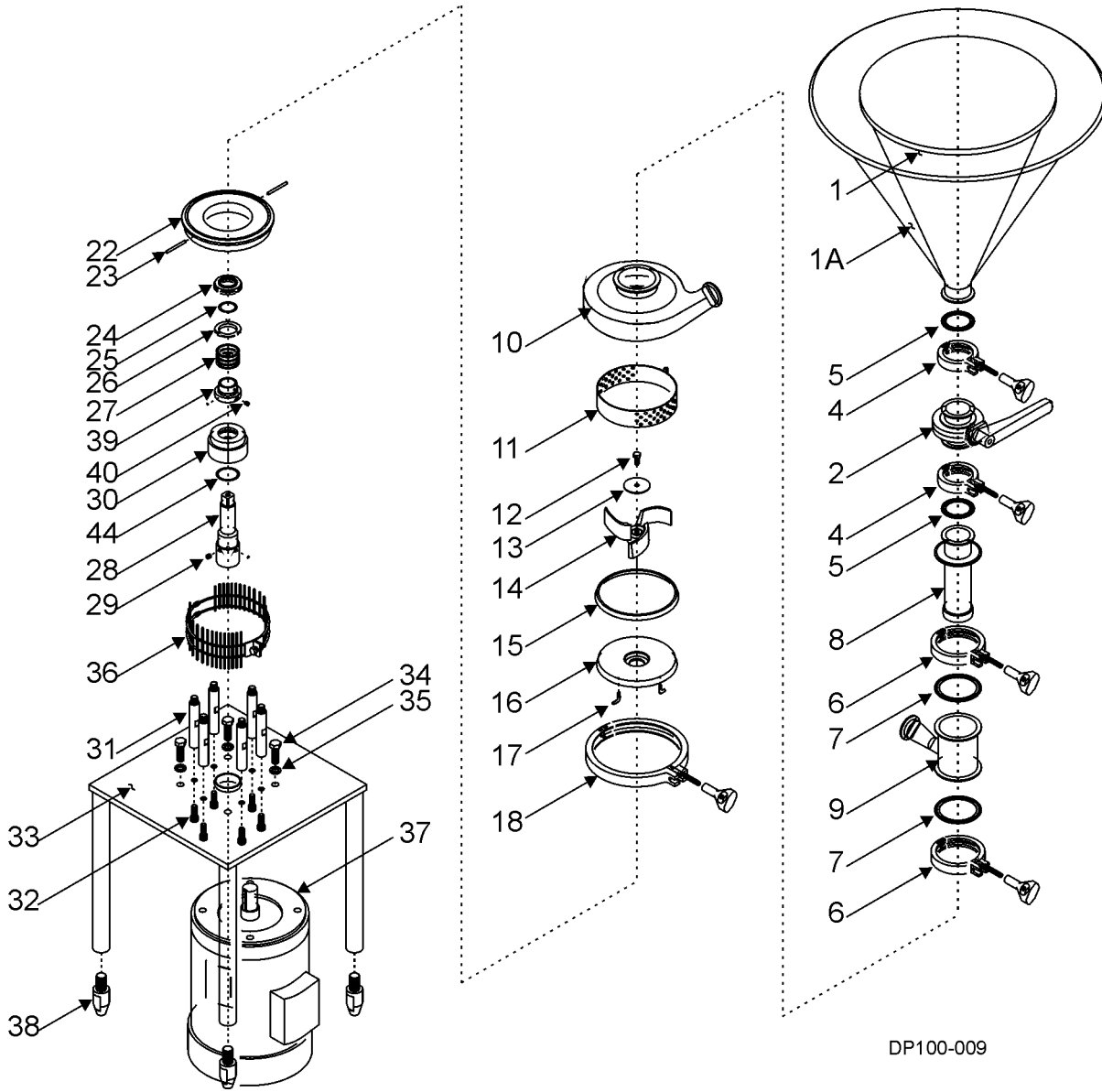

DP100-009

Puriti DTL Blender Model F2116MD

ITEM NO.	DESCRIPTION	QTY	PART NO.	NOTES
1	Hopper, 40 Degree	1	60306	
1A	Hopper, 60 Degree	1	60307	
2	Butterfly Valve, Manual S-51	1	60685	
4	Clamp	2	119-30	
5	Gasket, BUNA 2"	2	20-3	
6	Clamp	2	P119-287	
7	Gasket, BUNA 3"	2	20-5	
8	Diffuser and Suction Tube	1	60309	
9	Inlet Adapter, 3" x 1"	1	60310	
10	Casing,	1	60868	
11	Screen	1	60869	
12	Capscrew, Impeller, 18-8SS	1	30-151	
13	Washer, Impeller	1	60314	
14	Impeller	1	60315	
15	Casing Gasket	1	60101	
16	Backplate "D"	1	60316	
17	Pin, Backplate	2	60013	
18	Clamp, Casing	1	60081	
22	Ring Adapter	1	60320	
23	Pin, 3/16 x 2", Adapter	2	60634	
24	Carbon Seal	1	60086	
25	O-ring Seal, BUNA	1	N70216	
26	Cup	1	60089	
27	Spring	1	60092	
28	Stub Shaft	1	60865	
29	Setscrew, Stub Shaft	2	30-436	
30	Deflector	1	60867	
31	Spacer	6	60324	
32	Capscrew, Spacer	6	30-30	
33	Base	1	60326	
34	Capscrew, Motor, 18-8SS	4	30-103	
35	Lockwasher, 1/2", Motor	4	43-16	
36	Seal Guard	1	60329	
37	Motor C- Face, Standard 4 Poles 3 H.P.	1	2116	
38	Leg, Adjustable	4	60611	
39	Drive Collar	1	60095R1	
40	Setscrew, Drive Collar	2	30-178	
44	O-ring, Seal, BUNA	1	N70222	

F2116MD

Notes:

1. Complete Assembly

Puriti DTL Blender Model F3218MD

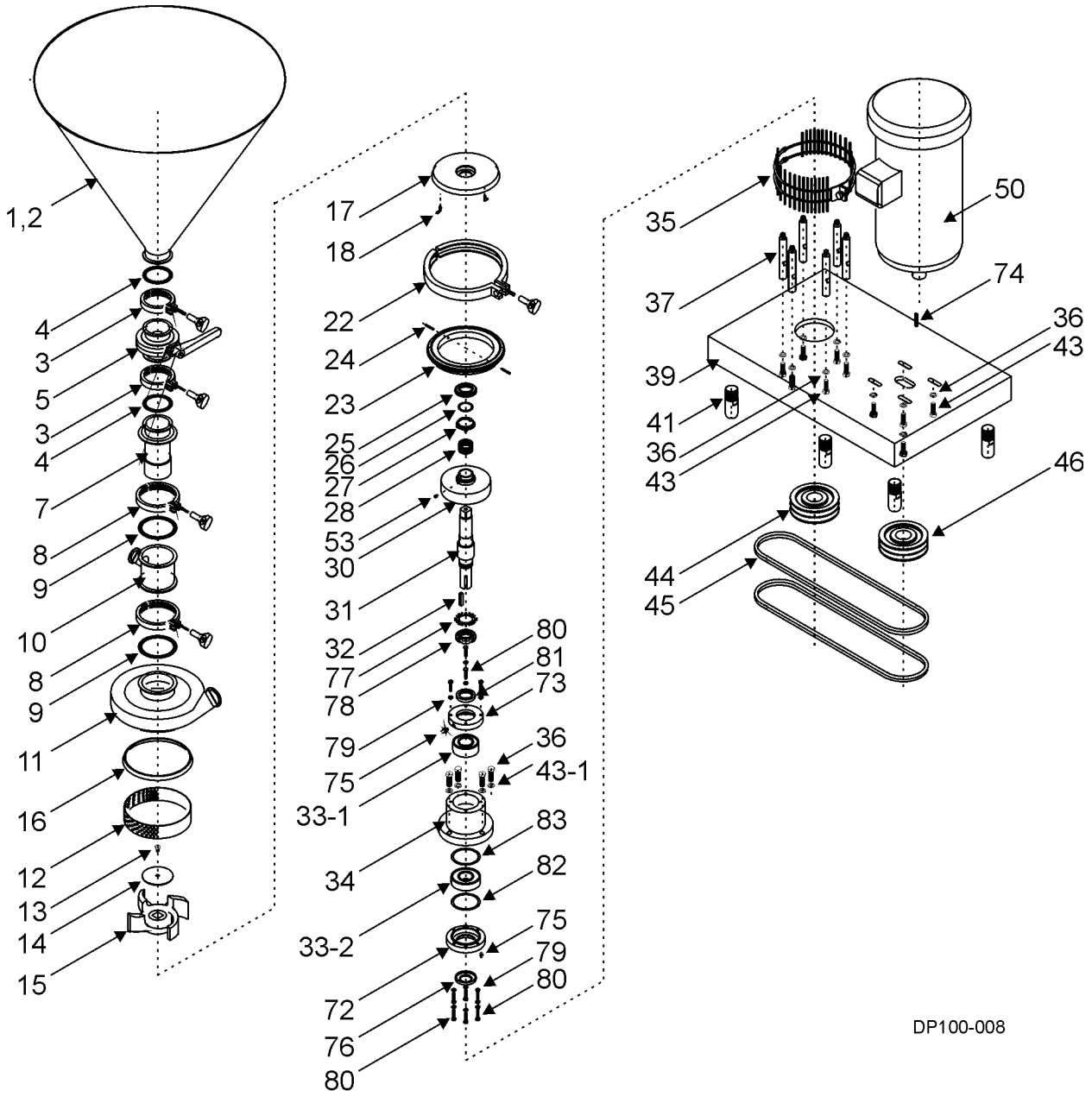

DP100-008

Puriti DTL Blender Model F3218MD

ITEM NO.	DESCRIPTION	QTY	PART NO.	NOTES
1	Hopper, 40 Degree	1	60343	
2	Hopper, 60 Degree	1	60344	
3	Clamp	2	119-34	
4	Diffuser Gasket	2	20-5	
5	Butterfly Valve, S-51	1	60686	
7	Diffuser and Suction Tube	1	60346	
8	Clamp	2	119-49	
9	Adapter Gasket	2	20-6	
10	Inlet Adapter Housing, 4" x 1-1/2"	1	60347	
11	Casing, 4" x 2"	1	60870	
12	Screen	1	60871	
13	Capscrew	1	30-656	
14	Washer, Impeller, Special	1	60351	
15	Impeller	1	60352	
16	Casing Gasket, BUNA	1	60103	
17	Backplate "D"	1	60353	
18	Pin, Backplate	2	60013	
22	Clamp	1	60082	
23	Adapter Ring	1	60354	
24	Pin, 3/16 x 2", Adapter	2	30-434	
25	Carbon Seal	1	60087	
26	O-ring Seal, BUNA	1	N70222	
27	Cup	1	60090	
28	Spring Seal	1	60093	
30	Collar Deflector	1	60355	
31	Shaft	1	60356	
32	Key Pulley/Shaft	1	60357	
33	Bearing, Sealed	1	030036000	
	Bearing, Sealed	1	60358	
34	Housing, Bearing	1	60359	
35	Seal Guard with capscrew and nut	1	60360	1
36	Lockwasher, 1/2", Housing Bearing	4	43-16	
	Lockwasher, 1/2", Spacer	6	43-16	
	Lockwasher, 1/2", Motor	4	43-16	
37	Spacer	6	60362	
39	Blender Base	1	60364	
41	Leg, Adjustable	4	60330	

F3218MD

Notes:

1. Complete Assembly

Puriti DTL Blender Model F3218MD

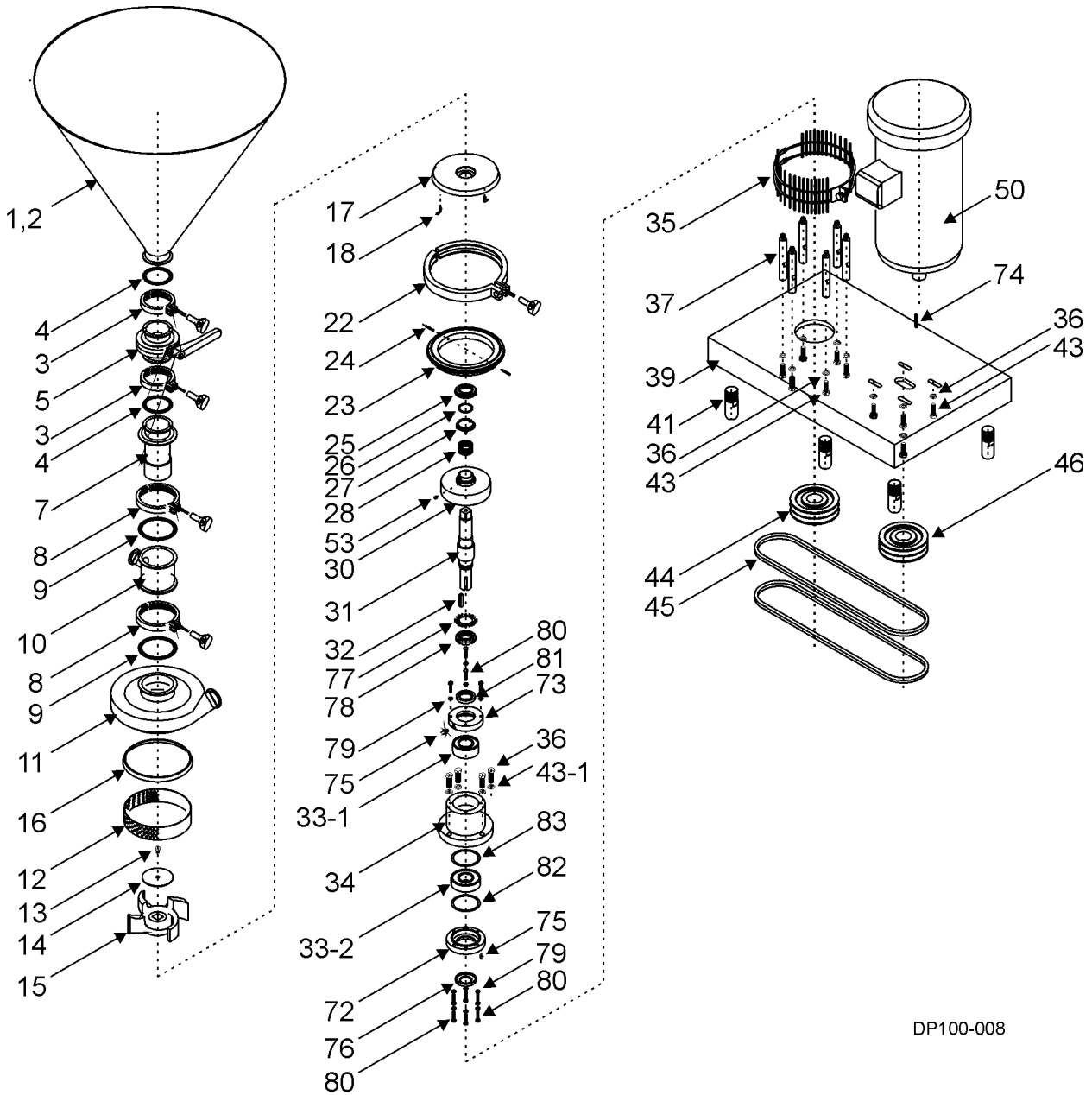

DP100-008

Puriti DTL Blender Model F3218MD

ITEM NO.	DESCRIPTION	QTY	PART NO.	NOTES
43	Capscrew	6	30-103	
	Capscrew	4	30-103	
	Capscrew	4	60863	
44	Pulley	1	30-127	
45	Drive Belt	2	60367	
46	Pulley	1	60368	
50	Motor 254TC 15 HP, 1700 RPM	1	3218	
53	Setscrew	2	30-178	
72	Posterior Plate	1	60603	
73	Interior Plate	1	60604	
74	Key Pulley/Motor	1	60701	
75	Greaser, 1/8"	2	BD0092001	
76	Retainer Posterior, 13844	1	60606	
77	Star Washer	1	60607	
78	Safety Nut	1	60608	
79	Lockwasher, Retainer Backplates, 1/4" SS	10	43-22	
80	Capscrew	10	30-102	
81	Retainer Interior	1	60883	
82	Shim O.D. 3.5" Thick 0.005"	*	60744	
83	Shim O.D. 3.5" Thick 0.010"	*	60747	

F3218MD2

Notes:

* Variable