

# Waukesha Cherry-Burrell

## Colloid Mill

For producing controlled, highly sheared, uniform emulsified products



- **Greater capacity**

Waukesha Cherry-Burrell Colloid Mills dispense product inline through larger openings. Clearance setting does not effect product movement. You get up to 50% more flow rate with less heat than other mills.

- **Easy clearance adjustment**

Just set a simple, calibrated ring. It locks in position in increments of .001 between .010 and .240 inches. No special tools. Less chance for error. Less downtime. Clearance adjustment can be made 'on the fly' during operation or when stopped.

- **Easy cleaning**

With the stator removed, you gain complete visibility. Comes off without tools. Also can be cleaned in place depending on application.

- **Longer bearing & seal life**

Shaft and bearing position is independent of clearance adjustment, so heavy duty, pre-loaded bearings can be used for longer life. Runs quieter, too.

- **Easy to Disassemble**

With only seven basic parts to the mill. Cleaning and inspection are quick and easy.



# Colloid Mill Dimensions

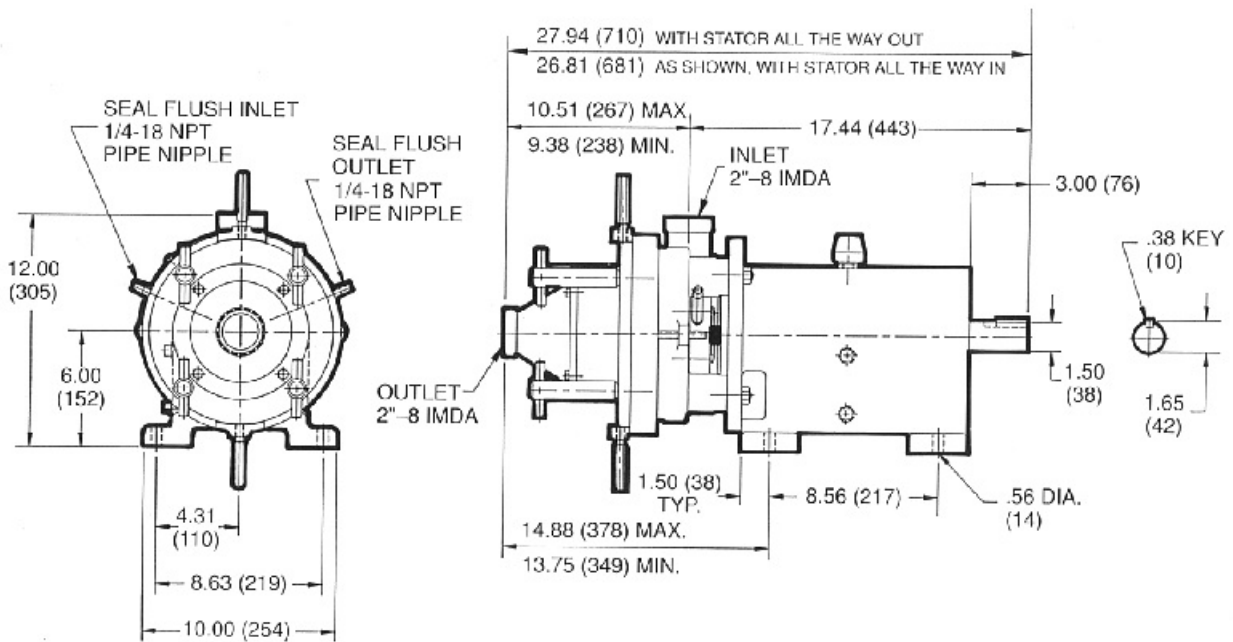

- **Waukesha Cherry-Burrell Design**

A serrated conical stator and serrated rotating cone make up the emulsifying head. Clearances are determined by moving the stator-not the shaft. Shaft, bearings and seals are all fixed.

### Simple Stator Adjustment

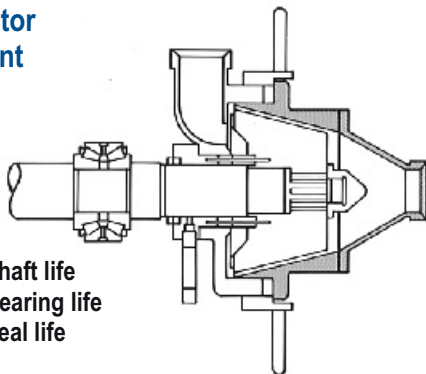

Longer shaft life  
Longer bearing life  
Longer seal life

- **Conventional Design**

Standard mills require the forward or backward movement of the shaft within its bearings to achieve desired clearance settings. Wear on parts affect emulsion results. Tools required. Errors, easy.

### Complicated Shaft Adjustment

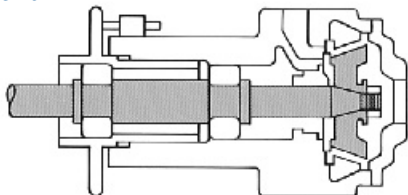

**ISO 9001  
CERTIFIED**

## Waukesha Cherry-Burrell Warranty

Seller warrants its products to be free from defects in materials and workmanship for a period of (1) year from the date of shipment. This warranty shall not apply to products which require repair or replacement due to normal wear and tear or to products which are subjected to accident, misuse or improper maintenance. This warranty extends only to the original buyer. Products manufactured by others but furnished by seller are exempted from this warranty and are limited to the original manufacturer's warranty.



**Waukesha  
Cherry-Burrell**

611 Sugar Creek Road  
Delavan, WI 53115  
Tel: 1.800.252.5200 or 262.728.1900  
Fax: 1.800.252.5012 or 262.728.4904  
E-mail: [custserv@gowcb.com](mailto:custserv@gowcb.com)  
Web site: <http://www.gowcb.com>