



SPX Process Equipment

Design Features

- Shear action for mixing that can be “tuned” to exactly the right amount of physical work—no more, no less.
- The number of passes which the product makes through the mixing zone can be controlled.
- Temperature rise normally associated with all shear-type mixing can be regulated
- Ability to make the materials in process pass through its multi-pass mixing zone not once, but many times during their residence within the mixer.

CR Mixer

Typical Applications

- Cake Icings
- Cheese Spread
- Cocoa Dispersion
- Collagen-Fibre
- Cosmetic Emulsions
- Cream Cheese
- Dissolving Gums and CMC
- Frozen Topping
- Icing Base
- Margarine
- Marshmallow
- Non-Dairy Topping
- Nougat
- Pharmaceutical Creams & Lotions
- Pie Topping
- Sponge Cake
- Surgical Foam
- Synthetic Foams



How it Works

Materials are pumped into the mixer through the cylindrical housing inlet. They are pulled through the forest of intermeshing pins of the multi-pass mixing zone into the opening of the inner rotor disc. The rotor vanes exposed at the openings of the inner disc impel and centrifugally sling the materials to the rotor periphery. Here the materials are directed back to the multi-pass mixing zone by the product sweeper or directing vanes.

The number of times the material is returned or recycled to and through the multi-pass zone depends on the RPM of the rotor and product consistency. The higher the rotor speed the more times the material in process is made to circulate and recirculate through the multi-pass zone, regardless of the net flow of product being pumped into the mixer inlet by a product metering pump. Mixing efficiency is further enhanced by imposing pressure by a valve in the mixer discharge line. Mixer Jacketing requires 5 gallons per minute of coolant flow at up to 50 pounds pressure.

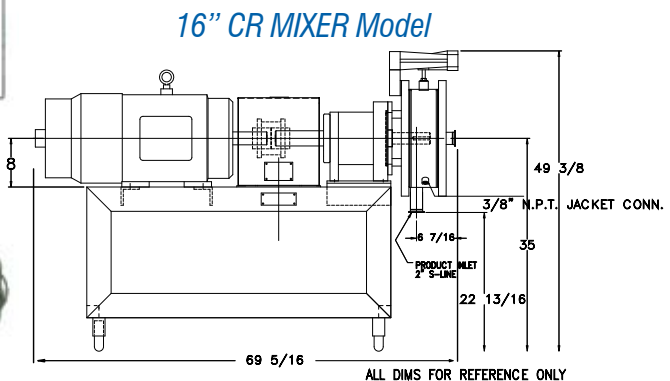
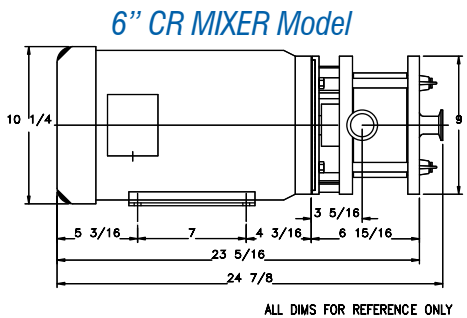
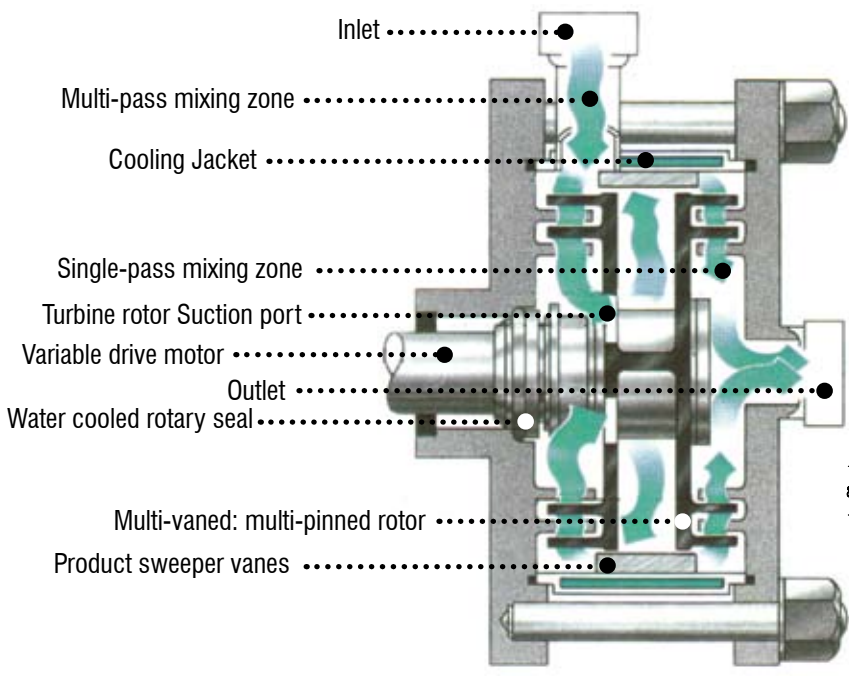

For more information about our worldwide locations, approvals and certifications, and local representatives, please visit our web site.

Web Site: www.spxpe.com
E-Mail: wcb@processequipment.spx.com



Packaging - Processing
Bid on Equipment
 1-847-683-7720
www.bid-on-equipment.com

611 Sugar Creek Road Delavan, WI 53115 Telephone: (262)728-1900 or (800)252-5200 Fax: (262)728-4904 or (800)252-5012

SPX Process Equipment reserves the right to incorporate our latest design and material changes without notice or obligation. Design features, materials of construction and dimensional data, as described in this bulletin, are provided for your information only and should not be relied upon unless confirmed in writing. Certified drawings are available upon request.
 Issued: PE-2800 4/07