



Operation and Maintenance Manual 200 Series Liquid Ring Self-Priming Pumps



CT100-145

**Read and understand this manual
prior to installing, operating or servicing this equipment.**

Table of Contents

Waukesha Cherry-Burrell Warranty	4
Shipping Damage or Loss	4
Warranty Claim	4
Safety	5
Care of Stainless Steel	6
Stainless Steel Corrosion	6
Alloy 88	6
Elastomer Seal Replacement Following Passivation	6
Introduction	7
Manual Content	7
Receiving Your Pump	7
Pump Characteristics	8
Performance Characteristics	8
Quality Control	8
Standard Construction	8
Construction Options	8
Leg Kit	8
Motors	8
Enclosure Options	8
Operating Parameters	8
Dimensions	9
Installation	10
Special Requirements for Liquid Ring Self-Priming Pump	10
General Requirements	10
Installation Safety Procedures	11
Pump Leveling	11
Type 4 Seal Flush Supply Installation	11
Electrical Connections	11
Before First Startup	12
Cleaning Pump and Piping	12
Cleaning Safety Procedures	12
Preliminary Test Run	12
Operation	13
Starting Pump	13
Stopping Pump	13
Maintenance	14
Scheduled Routine Maintenance	14
Disassembly of Pump	14
Type 1 Seal Disassembly	16
Type 4 Seal Disassembly	17
Inspecting Parts	17
Assembly of Pump	18
Backplate Assembly	18
Type 1 Seal Assembly	19
Type 4 Seal Assembly	19
Parts Lists	22
Seal Components All Pumps	22
2065LR Self-Priming Pump Parts	24
2085LR Self-Priming Pump Parts	25
Motor Mounts	26
Troubleshooting	27

Waukesha Cherry-Burrell Warranty

Seller warrants its products to be free from defect in materials and workmanship for a period of one (1) year from the date of shipment. This warranty shall not apply to products which require repair or replacement due to normal wear and tear or to products which are subjected to accident, misuse or improper maintenance. This warranty extends only to the original Buyer. Products manufactured by others but furnished by Seller are exempted from this warranty and are limited to the original manufacturer's warranty.

Seller's sole obligation under this warranty shall be to repair or replace any products that Seller determines, in its discretion, to be defective. Seller reserves the right either to inspect the products in the field or to request their prepaid return to Seller. Seller shall not be responsible for any transportation charges, duty, taxes, freight, labor or other costs. The cost of removing and/or installing products which have been repaired or replaced shall be at Buyer's expense.

Seller expressly disclaims all other warranties, express or implied, including without limitation any warranty of merchantability of fitness for a particular purpose. The foregoing sets forth Seller's entire and exclusive liability, and Buyer's exclusive and sole remedy, for any claim of damages in connection with the sale of products. In no event shall Seller be liable for any special consequential incidental or indirect damages (including without limitation attorney's fees and expenses), nor shall Seller be liable for any loss of profit or material arising out of or relating to the sale or operation of the products based on contract, tort (including negligence), strict liability or otherwise.

Shipping Damage or Loss

If equipment is damaged or lost in transit, file a claim at once with the delivering carrier. The carrier has signed the Bill of Lading acknowledging that the shipment has been received from WCB in good condition. WCB is not responsible for the collection of claims or replacement of materials due to transit shortages or damages.

Warranty Claim

Warranty claims must have a **Returned Goods Authorization (RGA)** from the Seller before returns will be accepted.

Claims for shortages or other errors, exclusive of transit shortages or damages, must be made in writing to Seller within ten (10) days after delivery. Failure to give such notice shall constitute acceptance and waiver of all such claims by Buyer.

Safety

READ AND UNDERSTAND THIS MANUAL PRIOR TO INSTALLING, OPERATING OR SERVICING THIS EQUIPMENT

Waukesha Cherry-Burrell recommends users of our equipment and designs follow the latest Industrial Safety Standards. At a minimum, these should include the industrial safety requirements established by:

1. Occupational Safety and Health Administration (OSHA), Title 29 of the CFR
Section 1910.212- General Requirements for all Machines
2. National Fire Protection Association, ANSI/NFPA 79
ANSI/NFPA 79- Electrical Standards for Industrial Machinery
3. National Electrical Code, ANSI/NFPA 70
ANSI/NFPA 70- National Electrical Code
ANSI/NFPA 70E- Electrical Safety Requirement for Employee Workplaces
4. American National Standards Institute, Section B11

Attention: Servicing energized industrial equipment can be hazardous. Severe injury or death can result from electrical shock, burn, or unintended actuation of controlled equipment. Recommended practice is to disconnect and lockout industrial equipment from power sources, and release stored energy, if present. Refer to the National Fire Protection Association Standard No. NFPA70E, Part II and (as applicable) OSHA rules for Control of Hazardous Energy Sources (Lockout-Tagout) and OSHA Electrical Safety Related Work Practices, including procedural requirements for:

- Lockout-tagout
- Personnel qualifications and training requirements
- When it is not feasible to de-energize and lockout-tagout electrical circuits and equipment before working on or near exposed circuit parts

Locking and Interlocking Devices: These devices should be checked for proper working condition and capability of performing their intended functions. Make replacements only with the original manufacturer's renewal parts or kits. Adjust or repair in accordance with the manufacturer's instructions.

Periodic Inspection: Industrial equipment should be inspected periodically. Inspection intervals should be based on environmental and operating conditions and adjusted as indicated by experience. At a minimum, an initial inspection within 3 to 4 months after installation is recommended. Inspection of the electrical control systems should meet the recommendations as specified in the National Electrical Manufacturers Association (NEMA) Standard No. ICS 1.3, Preventative Maintenance of Industrial Control and Systems Equipment, for the general guidelines for setting-up a periodic maintenance program.

Replacement Equipment: Use only replacement parts and devices recommended by the manufacturer to maintain the integrity of the equipment. Make sure the parts are properly matched to the equipment series, model, serial number, and revision level of the equipment.

Warnings and cautions are provided in this manual to help avoid serious injury and/or possible damage to equipment:



DANGER: marked with a stop sign.
Immediate hazards which *WILL* result in severe personal injury or death.



WARNING: marked with a warning triangle.
Hazards or unsafe practices which *COULD* result in severe personal injury or death.



CAUTION: marked with a warning triangle.
Hazards or unsafe practices which *COULD* result in minor personal injury or product or property damage.

Care of Stainless Steel

Stainless Steel Corrosion

Corrosion resistance is greatest when a layer of oxide film is formed on the surface of stainless steel. If film is disturbed or destroyed, stainless steel becomes much less resistant to corrosion and may rust, pit or crack.

Corrosion pitting, rusting and stress cracks may occur due to chemical attack. Use only cleaning chemicals specified by a reputable chemical manufacturer for use with 300 series stainless steel. Do not use excessive concentrations, temperatures or exposure times. Avoid contact with highly corrosive acids such as hydrofluoric, hydrochloric or sulfuric. Also avoid prolonged contact with chloride-containing chemicals, especially in presence of acid. If chlorine-based sanitizers are used, such as sodium hypochlorite (bleach), do not exceed concentrations of 150 ppm available chlorine, do not exceed contact time of 20 minutes, and do not exceed temperatures of 104°F (40°C).

Corrosion discoloration, deposits or pitting may occur under product deposits or under gaskets. Keep surfaces clean, including those under gaskets or in grooves or tight corners. Clean immediately after use. Do not allow equipment to set idle, exposed to air with accumulated foreign material on the surface.

Corrosion pitting may occur when stray electrical currents come in contact with moist stainless steel. Ensure all electrical devices connected to the equipment are correctly grounded.

Alloy 88

Waukesha Alloy 88 is the standard rotor material for Universal I, Universal II, Universal Lobe, Universal 420/520 and 5000 Series Rotary PD pumps. This alloy was developed specifically for corrosion resistance and close operating clearance requirements of high performance rotary positive displacement pumps. Alloy 88 is a nickel based, corrosion-resistant, non-galling or seizing material. The ASTM designation is A494 Grade CY5SnBiM (UNS N26055), and the material is listed in the 3-A Sanitary Standards as acceptable for product contact surfaces.

The above properties make Alloy 88 the ideal material for Waukesha stainless steel PD pumps. The non-galling rotors permit close operating clearances in the liquid end. This provides low slip and minimum shear damage. The rotors will not gall or seize if they come in contact with the body or cover during operation.

The corrosion resistance of Alloy 88 is approximately equal to AISI 300 Series Stainless Steel. However, Alloy 88 has limited resistance to certain aggressive chemicals that may be commonly used in contact with AISI 300 Series Stainless Steel.

Do not use Alloy 88 in contact with nitric acid. Nitric acid is commonly used to passivate new installations of stainless steel equipment. Do not allow nitric acid based passivation chemicals to contact Alloy 88 rotors. Remove the rotors during passivation and use a separate pump to circulate the passivation chemicals. Also, if nitric acid-based CIP cleaning chemicals are used, remove the rotors prior to CIP cleaning and clean them separately by hand in a mild detergent.

If you have questions regarding other aggressive chemicals, please contact Waukesha Cherry-Burrell Application Engineering for assistance.

Elastomer Seal Replacement Following Passivation

Passivation chemicals can damage product contact areas of WCB equipment. Elastomers (rubber components) are most likely to be affected. Always inspect all elastomer seals after passivation is completed. Replace any seals showing signs of chemical attack. Indications may include swelling, cracks, loss of elasticity or any other noticeable changes when compared with new components.

Introduction

Manual Content

Maintenance procedures in this manual do not cover aseptic or high pressure pump applications. These are covered in special addendums available from your Waukesha Cherry-Burrell representative.

Receiving Your Pump

All ports are covered at the factory to keep out foreign objects during transit. If covers are missing or damaged, remove the pump cover for a thorough inspection of fluid head. Be sure pumping head is clean and free of foreign material before rotating shaft.

Each Waukesha pump is shipped completely assembled, lubricated and ready for use. Review “Operation” on page 13 before operating your pump.

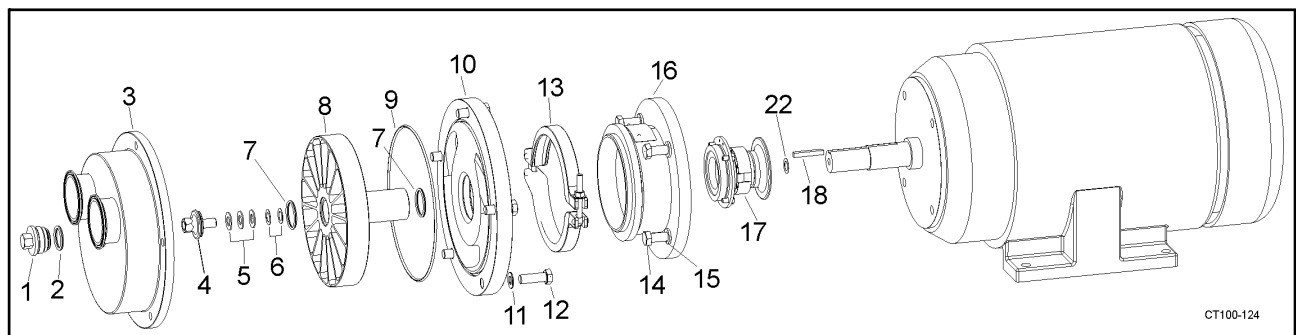

Figure 1 - Common Part Identification

- | | | |
|--|--------------------------|--------------------------------------|
| 1. Plug Inspection | 8. Impeller | 14. Cap Screws |
| 2. O-Ring | 9. O-ring | 15. Lock Washers |
| 3. Casing | 10. Backplate | 16. Motor Adapter |
| 4. Impeller Retainer | 11. Flat Washers | 17. Seals (details shown on page 22) |
| 5. Spring Nut (2065LR) /
Belleville Washer (2085LR) | 12. Backplate Cap Screws | 18. Key |
| 6. Spacer Nut (2065LR) /
Shim Washers (2085LR) | 13. Clamp | 22. Motor Shims |
| 7. O-ring | | |

NOTE: Reorder information is available on page 24.

Pump Characteristics

The 200LR (Liquid Ring) Self-Priming Pump handles products with entrained air as well as maintaining its prime when other pumps become air bound. This feature makes the 200LR the best choice for complete emptying of tanks and lines during normal process or cleaning-in-place (CIP).

In addition to being an excellent CIP return pump, the 200LR can run in either direction, making it possible to fill or empty tanks with the same pump.

The 200LR Self-Priming Pump is built for extremely durable service. The casing, backplate and impeller/stub shaft are 316L stainless steel for extra strength and resistance to line shock and corrosion. Large bearings and shaft provide positive alignment and minimize vibration.

The pump is available with two standard seal types:

- Type 1- Single mechanical seal, external mounted and balanced.
- Type 4 - Double mechanical seal with flush housing.

All seal components are interchangeable between models. All seal assemblies utilize an externally mounted balanced rotary seal for longer seal life and better sealing capability. The stationary seal face is reversible and replaceable.

Performance Characteristics

Quality Control

Prior to shipment, each pump undergoes a performance test for design flow rate and design pressure.

Standard Construction

- Casing: 316L Stainless Steel
- Port Connections: S-Line
- Backplate: 316L Stainless Steel
- Impeller W/Integral Shaft: 316L Stainless Steel
- Impeller Retainer: 316L Stainless Steel
- Shaft Seal: Single Mechanical, External Balanced (Type 1)
- Rotary Seal Material: Carbon
- Stationary Seal: Siliconized Graphite
- Elastomers: FDA approved Viton[®]
- Finish: All product contact surfaces are 316L stainless steel with 32Ra finish.
- Motor adapter: Stainless steel
- Mounting: JM Motor

Construction Options

Ports

- 2.5" S-line fittings
- Optional casing 1/2" or 1" drain with S-clamp connection available.

Seal Type

- Single mechanical seal, external mounted and balanced (Type 1 shaft seal)
- Double mechanical with flush (Type 4 shaft seal)
- WFI - special Type 4 shaft seal flush piping for water used in injection applications
- Commercially available seals (Contact your WCB representative for details.)

Rotary Seal Material

Purebide
Silicone Carbide
Tungsten Carbide

Stationary Seal

Silicone Carbide
Tungsten Carbide

Elastomers

EPDM (FDA approved)
Silicone (FDA approved)
Kalrez[®]

Finishes/Product Contact Surfaces

Electro-Polish (20Ra or 25Ra)

Leg Kit

“Motor Mounts” on page 26.

Motors

- NEMA JM (standard) totally enclosed fan cooled (TEFC) for close-coupled pumps.
- 1750 3-phase 230/460 volt.

Enclosure Options

Washdown
Explosion-proof
Severe Duty/Chemical Duty

Operating Parameters

Nominal Capacity

Up to 180 U.S. GPM (40 Cubic Meters/Hr.)

Differential Pressure

Up to 195 Feet (60 Meters)

Nominal Speeds

1450 - 50HZ
1750 - 60HZ

Dimensions

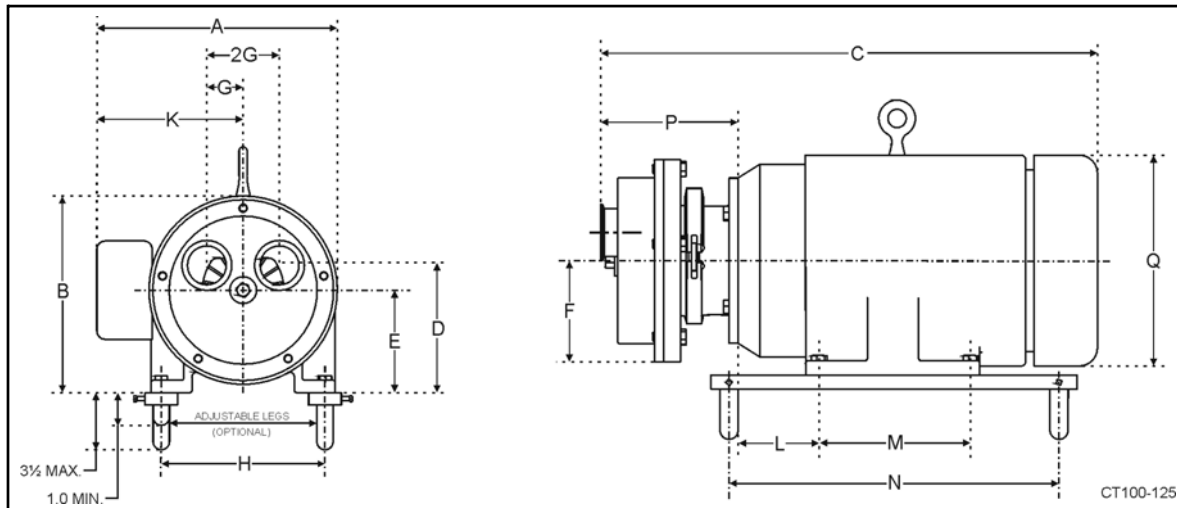

Figure 2 - Foot Print Dimensions

ITEM	DIMENSION FOR 2065LR 213JM AND 215JM MOTOR FRAME		DIMENSION FOR 2085LR 254JM AND 256JM MOTOR FRAME	
	IN	MM	IN	MM
A	13.44	341	14.9	379
B	10.34	263	12	305
C	23.51	597	27.4	697
D	6.51	165	7.75	197
E	5.25	133	6.25	159
F	4.56	116	5.50	140
G	1.88	48	2.25	57
2G	3.76	95	4.50	114
H	8.50	216	10.0	254
K	8.37	213	8.9	227
L	5.38	137	6.5	165
M	213JM = 5.5 215JM = 7.0	213JM = 140 215JM = 178	254JM = 8.25 256JM = 10.0	254JM = 209 256JM = 254
N	13.88	353	18.0	475
P	7.92	201	7.8	198
Q	10.18	259	11.5	292

Installation

Special Requirements for Liquid Ring Self-Priming Pump

Liquid ring self-priming pumps are designed for applications with large amounts of entrained air. CIP return pump applications involve intermittent flow from tank with air entering supply line. Suction lift applications evacuate air from supply line lifting liquid into pump to begin pumping. Suction lift up to 23 feet (7 meters) is possible.

For pump to work correctly, casing first must be full of liquid. If casing is completely dry or has too little liquid, it will not be able to self-prime and operate as intended. Correct installation piping helps ensure casing remains full of liquid and ensures trouble-free operation. Installation piping may include:

- **Vertical Discharge Piping:** Ensures backflow into casing for CIP return or similar applications. Install vertical section of pipe no less than 3 feet (1 meter) long in discharge piping (Figure 3).
- **Vertical Suction Piping:** For suction lift applications, install vertical section of pipe no less than 3 feet (1 meter) long in suction and discharge piping. This will prevent backflow (due to siphon effect) from evacuating liquid in casing (Figure 4).

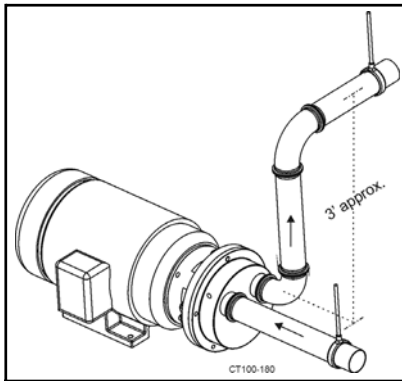

Figure 3 - Vertical Discharge

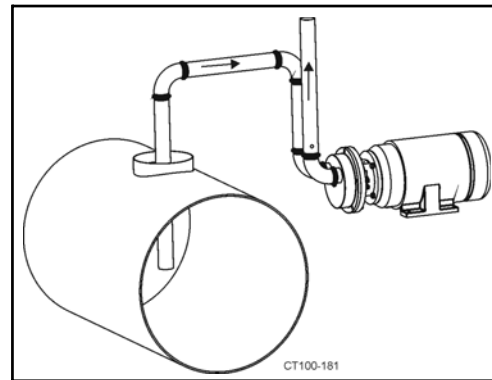

Figure 4 - Vertical Suction and Discharge

- **Foot or Check Valve in Suction Piping:** For suction lift applications not allowing vertical suction piping (Figure 4), install foot or check valve to prevent backflow and siphon effect from evacuating liquid in casing.
- **Leak-Free Suction Piping:** Air leaks in suction piping will reduce pump performance and may allow air in faster than pump is able to pump it away. This is especially important for suction lift applications requiring long suction lift.

General Requirements

CAUTION: Pump and piping may contain sharp edges. Wear gloves during installation and service of pump to help avoid injuries from these hazards.

- Install pump near as practical to liquid supply.
- Install shutoff valves to isolate pump from supply and discharge lines allowing pump service without draining system.
- Keep supply piping short and straight to keep pump supplied with liquid and prevent damaging cavitation.
- Use line size, particularly for inlet supply line, equal to or larger than connection size on pump.
- Ensure joints in suction line are well sealed preventing air leaks.
- Support supply and discharge piping near pump preventing strain on pump casing.
- Install pipe anchor between joint and pump if expansion joint is used.
- Allow easy access to pump for service and inspection during operation.
- Ensure mounting structures are properly sized supporting weight of pump.
- Consider local noise level regulations.
- Ensure pump motor type is suitable for environment where pump is to be operated.
- Protect motor from flooding.

CAUTION: Pumps intended for use in hazardous environments - eg., explosive, corrosive, etc. - must use a motor with appropriate enclosure characteristics. Failure to use an appropriate motor type may result in serious damage and/or injury.

Installation Safety Procedures

- Any system throttling valves or similar devices controlling flow rate must be installed in discharge line. **Do not** install devices in supply line. Restriction in supply line may cause cavitation and pump damage.
- "Water hammer" in system can damage pump and other system components. Water hammer often occurs when valves in system are suddenly closed causing lines to move violently and with a loud noise. When this condition is present, find and eliminate source of water hammer. One way to eliminate water hammer is to slow down actuation speed of valve.
- Do not expose pump to freezing temperatures with liquid in casing. Frozen liquid in casing will damage pump. Drain casing before exposing to freezing temperatures.

Pump Leveling

Level pump by loosening set screws (Figure 5, item A) to adjust length of legs.

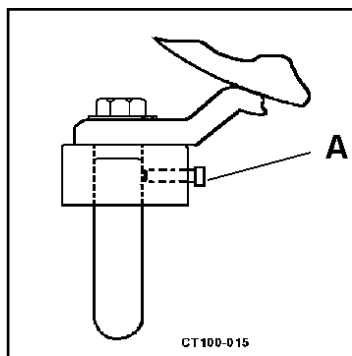

Figure 5 - Set Screw Location

Type 4 Seal Flush Supply Installation

Attach seal flush supply to bottom 1/4-inch pipe-threaded hole in flush housing. Drain tubing attached to top hole allowing continuous flooding and moderate pressure to be supplied to seals. (Figure 6).

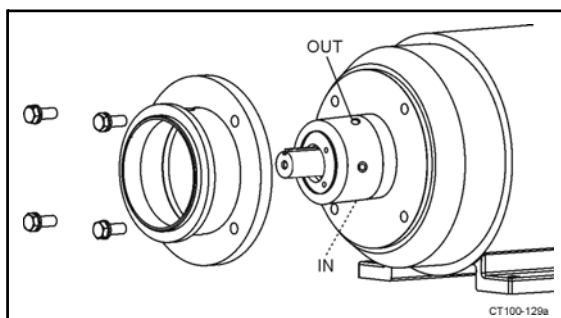

Figure 6 - Type 4 Flush Housing

Electrical Connections

WARNING: To avoid electrocution, all electrical installation should be done by a registered electrician following Industry Safety Standards. All power must be off and locked out during installation.

- Read motor manufacturer's instructions before making installation. Follow manufacturer's lubrication schedules.
- Check motor nameplate to confirm motor is compatible with all wiring, switches, starters and electrical supply. Ensure overload protections are correctly sized. (Figure 7).

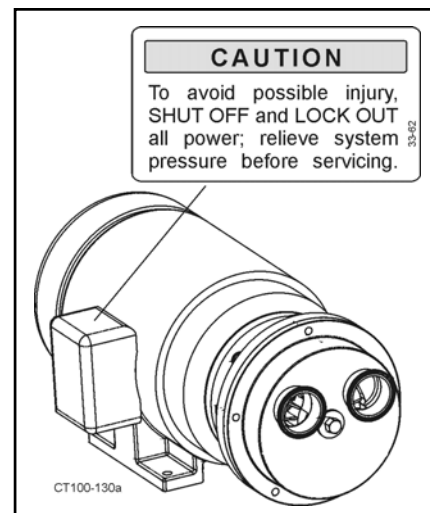

Figure 7 - Replaceable Label Location

Before First Startup

Cleaning Pump and Piping

Disassemble pump and clean all product contact parts and seal parts prior to first operation. Follow instructions in “Cleaning Safety Procedures” on page 12 and “Scheduled Routine Maintenance” on page 14. The pump and piping system should be thoroughly cleaned of any materials accumulated during installation. Do not use pump to clean system. Check motor for proper rotation (looking at front of pump, motor should rotate counter-clockwise when discharge is on right side, clockwise when discharge is on left side).

- Pump housing should be filled with liquid before startup.
- Maximum inlet pressure to the pump should not exceed 150 PSI.
- Available NPSH should be greater than or equal to the NPSH required by the pump.

Cleaning Safety Procedures

Manual Cleaning



DANGER: Never attempt cleaning equipment while it is operating.



WARNING: To prevent an accidental startup, power source should be locked out using lock and key.

- Lock out electrical power and shut off all air prior to cleaning equipment.
- Keep electrical panel covers closed and power off when washing equipment.
- Do not use toxic and/or flammable solvents.
- Clean up spills as soon as possible.
- Wear proper protective clothing.

Cleaning-In-Place (CIP)

- Ensure all connections in cleaning circuit are properly applied and tight to avoid contact with hot water or cleaning solutions.
- Establish safe procedures to avoid automatic startup while servicing equipment in circuit when cleaning cycle is controlled from remote or automated cleaning center.

Preliminary Test Run

Test system using a preliminary run with materials to be pumped. During testing, **DO NOT** run pump to produce final product.

See “Starting Pump” on page 13.

Ammeter Test

Temporarily install an ammeter in electrical service if uncertain about pump selection and application.



WARNING: To avoid electrocution, ammeter installation should be done by a registered electrician.

Operate pump under process conditions and check motor amp draw versus nameplate full load rating. If amp draw exceeds motor rating, a system change or pump change is required.

Recheck motor amp draw if liquid and/or process conditions change (higher specific gravity, higher viscosity).

Operation

Before proceeding ensure pump has been correctly installed as described in “Installation” on page 10.

Starting Pump

1. Start flow of filtered flush water (recommended rate is approximately 5 US gallons per hour) before operating the pump if pump has flush seal option.
2. Start pump motor.
3. Check pump to verify liquid is flowing and all piping connections and seals are leak free.
4. Ensure pump is not operating against a closed discharge. Continued operation against a closed discharge will heat liquid in casing to boiling and lead to pump damage.

Stopping Pump

1. Shut off power to pump motor.

NOTE: Liquid in system can flow freely through pump; pump does not act as a shutoff valve.

2. Shut off supply and discharge lines.

Maintenance

Scheduled Routine Maintenance

A scheduled routine maintenance program can extend life of pump. Keep maintenance records to help pinpoint potential problems and causes.

- Check for unusual noise, vibration and bearing temperatures.
- Inspect pump and piping for leaks.
- Check mechanical seal area for leakage. No leakage is desired.
- Check backplate gasket for wear/damage.
- Lubricate bearings. (See motor manufacturer for correct specifications.)
- Analyze vibration.
- Check discharge pressure.
- Monitor temperature.

Disassembly of Pump

Tools Required

Soft-face hammer

3/4" socket wrench

3/4" open end wrench

1/8" allen wrench

1/2" open end wrench

1/4" allen wrench

7/16" open end wrench

Disassembly Procedure

1. Shut off product flow to pump and relieve any product pressure.
2. Shut off and lockout power to pump.
3. Disconnect suction and discharge pipe fittings.
4. Remove bolts and washers connecting front cover to backplate (Figure 8, item A).

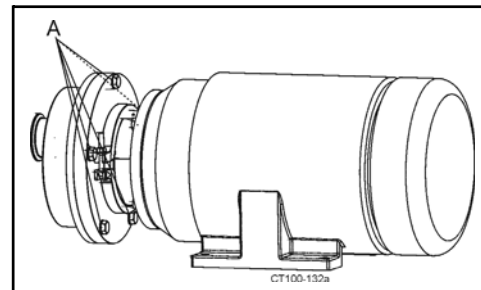

Figure 8 - Remove Backplate Bolts

- Remove front cover (Figure 9, item A) from pump. Place front cover on a protected surface with ports up.

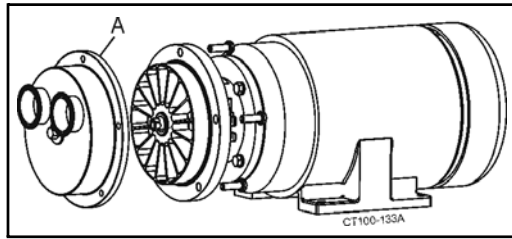

Figure 9 - Remove Cover

- Remove backplate cover o-ring (Figure 10, item A).

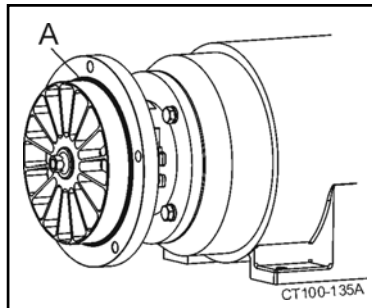

Figure 10 - Remove Cover O-ring

- Remove shims, belleville washers and impeller retainer with o-ring (Figure 11, items A, B, D and C).

NOTE: Tap wrench handle with soft-face hammer to loosen impeller retainer. It may be necessary to block impeller with nylon dowel to assist in removing impeller retainer.

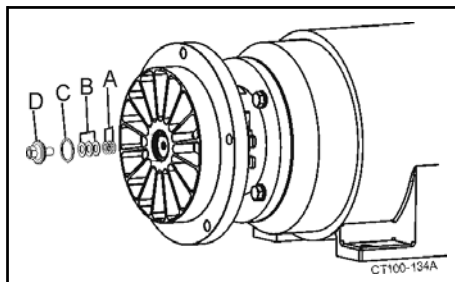

Figure 11 - Remove Shims, Belleville Washers and Impeller Retainer

- Remove clamp securing backplate to motor adapter (Figure 12, item A).

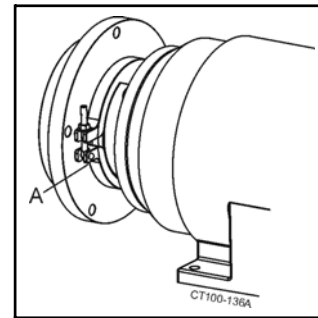

Figure 12 - Remove Clamp

- Pull impeller, backplate, and seal assembly from motor shaft (Figure 13). Place assembly face down on impeller vanes on a protected surface.

NOTE: Use a wheel puller if assembly cannot be removed from motor shaft by hand.

CAUTION: Handle the impeller/backplate assembly with care to prevent damage to seal components.

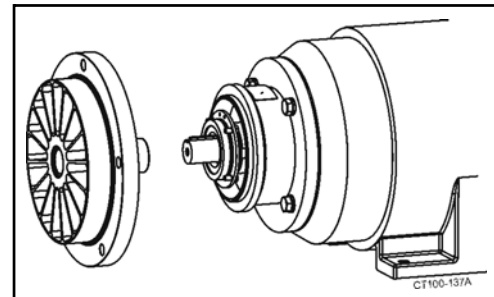

Figure 13 - Remove Impeller, Backplate and Seal Assembly

For "Type 1 Seal Disassembly," turn to page 16.
For "Type 4 Seal Disassembly," turn to page 17.

Type 1 Seal Disassembly

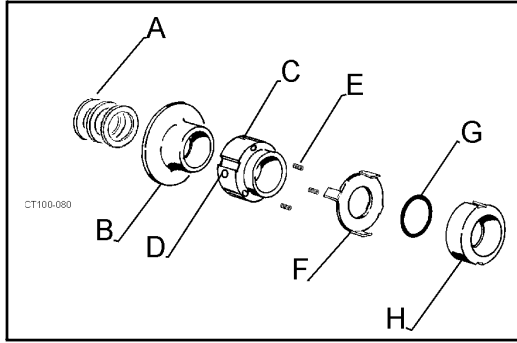

Figure 14 - Type 1 Seal Components

1. Remove deflector (Figure 14, item B).

NOTE: Drive key and shims (Figure 14, item A) remain on motor shaft. If impeller is replaced, add or remove shims as necessary.

2. Loosen set screws (2) (Figure 14, item D) in spring retainer (Figure 14, item C). Slide retainer and washer (Figure 14, item F) off shaft. Save springs (3) (Figure 14, item E).
3. Use backplate to slide rotary seal up impeller shaft approximately 1-1/2 inches (Figure 15).



Figure 15 - Move Rotary Seal Up Shaft

4. With backplate resting on impeller, push rotary seal toward backplate until o-ring is free (Figure 16).



Figure 16 - Push Rotary Seal Down Releasing O-ring

5. Remove o-ring and lift rotary seal off shaft (Figure 14, item G and H).



CAUTION: To avoid seal failure, DO NOT place fingers on seal face.

6. Lift backplate off impeller.
7. Remove four 1/4" hex bolts and stationary seal retainer ring (Figure 17, items A and B).

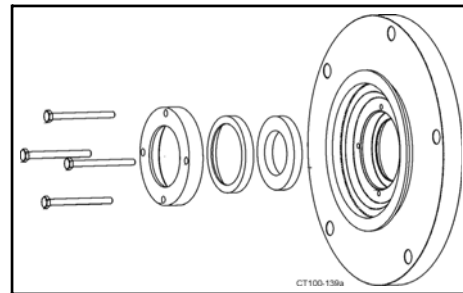

Figure 17 - Remove Stationary Seal

8. Pull stationary seal and L-gasket out of backplate (Figure 17, items C and D).

NOTE: The stationary seal is brittle. Prying or hammering on seal plate can shatter seal. If stationary seal cannot be removed by hand, place 2-1/4 inch diameter plastic or wood rod on impeller side of seal and apply even pressure to dislodge.

Type 4 Seal Disassembly

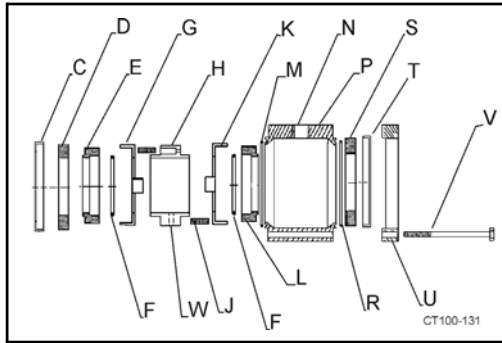

Figure 18 - Type 4 Seal Components

1. Remove cap screws from seal housing. (Figure 19, item A).

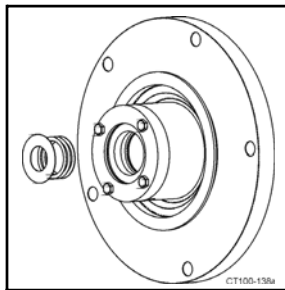

Figure 19 - Remove Screws from Housing

2. Carefully lift off seat retainer, o-ring, L-gasket, stationary seal and flush housing (Figure 18, items P, R, T, S and U).
3. Loosen set screws (2) in spring retainer. (Figure 18, items W and H).
4. Lift off rotating seal components:
 - Rotary Seal (Figure 18, item L)
 - O-ring (Figure 18, item F)
 - Washer (Figure 18, item K)
 - Spring Retainer (Figure 18, item H)
 - Springs (6 springs: 3 up, 3 down) (Figure 18, item J)
 - Washer (Figure 18, item G)
5. Use backplate to slide rotary seal up impeller shaft approximately 1-1/2 inches (Figure 20).



Figure 20 - Move Rotary Seal Up Shaft

6. With backplate resting on impeller, push rotary seal toward backplate until o-ring is free (Figure 21).



Figure 21 - Push Rotary Seal Down Releasing O-ring

7. Pull stationary seal and L-gasket out of backplate (Figure 18, items C and D).

NOTE: The stationary seal is brittle. Prying or hammering on seal plate can shatter seal. If stationary seal cannot be removed by hand, place 2-1/4 inch diameter plastic or wood rod on impeller side of seal and apply even pressure to dislodge.

Inspecting Parts

- Examine all seal surfaces and replace scratched, cracked and/or braised seals.
- Inspect all o-rings and o-ring seats for abrasions, cuts or other wear potentially causing leakage.
- Clean all seal areas and alignment surfaces.

NOTE: Stationary seals are **reversible**. Use **both sides** before replacing.

NOTE: Replace rotary seal when seal face extends less than 1/32 inch (1mm) from body (Figure 22).

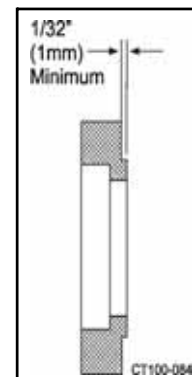

Figure 22 - Replace Rotary Seal if Less than Minimum

Assembly of Pump

Tools Required

Soft-face hammer

3/4" socket wrench

.020" feeler gage

3/4" open end wrench

1/8" allen wrench

1/2" open end wrench

1/4" allen wrench

7/16" open end wrench

Backplate Assembly

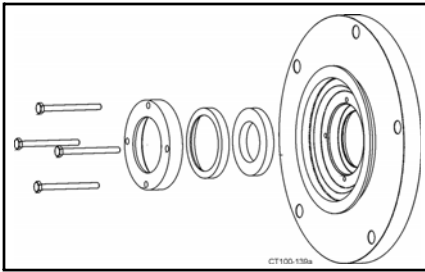

Figure 23 - Stationary Seal Assembly

1. To determine number of shims needed to space impeller from backplate while parts are in metal to metal contact, hold impeller and backplate in place on motor shaft and check shimming of impeller location (Figure 24). If necessary, add or remove shims from motor shaft so space between backplate and impeller face is .020. When .020 clearance is achieved, clamp backplate, assemble impeller retainer bolt and check clearance again.

NOTE: Any axial movement of shaft should not be added to .020 nominal clearance (Figure 24). If needed, change clearance by adding or removing shims. Shims (Figure 25, item A) are added on drive shaft (Figure 25, item C) behind impeller shaft (Figure 25, item B). Clean all parts and lubricate all elastomer (rubber-like) parts with sanitary lubricant.

2. Remove impeller and backplate leaving shims on motor shaft.
3. Clean all parts and lubricate all elastomer (rubber-like) parts with sanitary lubricant.
4. Insert L-gasket (Figure 23, item D) into backplate seal cavity.

5. Place stationary seal into L-gasket. (Figure 23, item C and D).
6. Place seat retainer over stationary seal and secure retainer with four 1/4-20 x 1/2 inch hex head cap screws. (Figure 23, item B and A).
7. Tighten cap screws evenly.
8. Place impeller shaft end up on a clean flat surface and slide assembled backplate onto impeller shaft.

NOTE: Avoid hitting stationary seal against impeller shaft to prevent seal from breaking.



CAUTION: Handle impeller/backplate assembly with care to prevent damaging seal components.

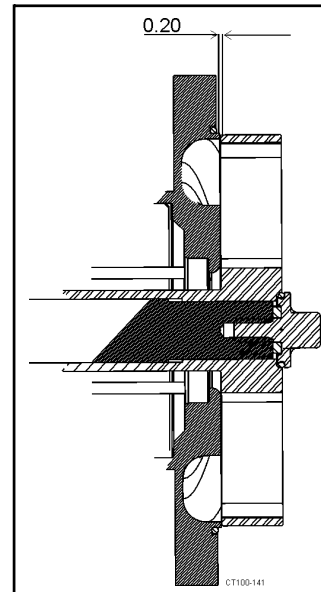

Figure 24 - Clearance Between Impeller and Backplate

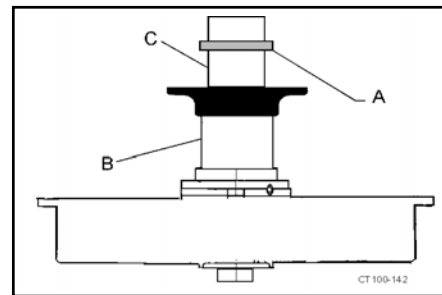

Figure 25 - Shims Locations

For "Type 1 Seal Assembly," turn to page 19, column I.
For "Type 4 Seal Assembly," turn to page 19, column II.

Type 1 Seal Assembly

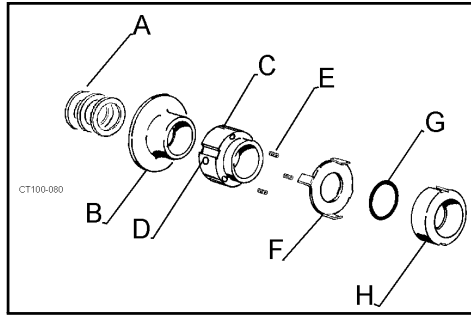

Figure 26 - Type 1 Seal Components

1. Carefully place rotary seal in position over impeller shaft and down against stationary seal.
2. Lubricate and slide seal assembly o-ring onto impeller shaft. (Use the spring retainer as a tool to push o-ring into rotary seal.) (Figure 27).

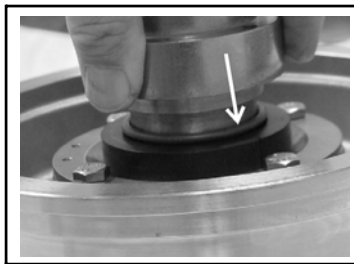

Figure 27 - Install O-ring Using Spring Retainer.

3. Slide tabbed washer (Figure 26, item F) over impeller shaft and engage tabs of washer into notches on outside of rotary seal. (Figure 26, item F and H).
4. Install three seal springs into holes in spring retainer (Figure 26, item C and E). Hold springs in place with RTV silicone sealant.
5. Slide spring retainer over impeller shaft until slots in spring retainer engage drive tabs on washer and springs rest against washer (Figure 26).
6. With backplate against impeller, push spring retainer down to compress springs until length of visible spring is approximately 1/8".
7. Lock spring retainer in place by tightening set screws (2) (Figure 26, item D).
8. Install deflector onto impeller shaft (Figure 26, item B).

To conclude assembly, turn to page 20, "Backplate Assembly".

Type 4 Seal Assembly

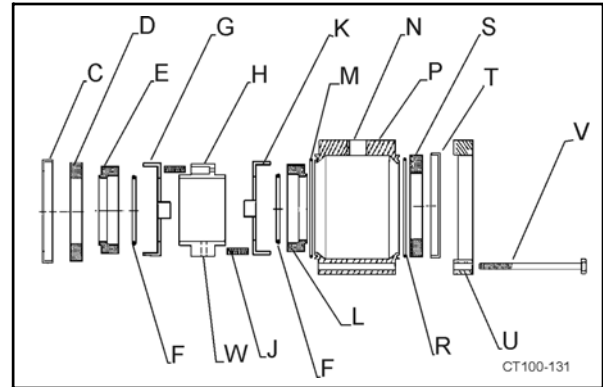

Figure 28 - Type 4 Seal Components

1. Install L-gasket in backplate (Figure 28, items B and C) and seat retainer. (Figure 28, item T).
2. Install stationary seals (Figure 28, item S) in L-gaskets.
3. Place backplate and rotary seal onto impeller shaft.
4. Temporarily place .020" shims 180 degrees apart between impeller and backplate to preset clearance. **Remove shims before final assembly.** (Figure 29).

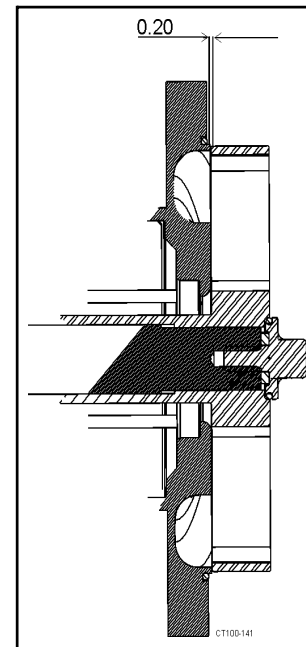

Figure 29 - Place Shims Between Impeller and Backplate

- Slide o-ring (Figure 28, item F) onto shaft and use spring retainer to push o-ring into rotary seal (Figure 30).

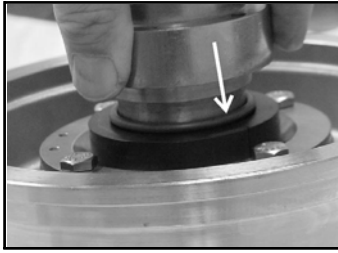

Figure 30 - Install O-ring Using Spring Retainer.

- Place washer (Figure 28, item G) over rotary seal with tabs in outside diameter notches.
- Place three springs (Figure 28, item J) in one side of spring retainer holding them in place with silicone sealer. With springs down slide spring retainer onto impeller shaft against washer.
- Place remaining three springs in spring retainer.
- Slide washer and o-ring (Figure 28, items K and F) onto shaft against spring retainer. Use spring retainer to push o-ring into rotary seal.
- Remove 1/4 NPT plug from center port on flush housing (Figure 28, item N).
- Install o-rings (Figure 28, items R and M) in both ends of housing.
- Install L-gasket in seat retainer. (Figure 28, items T and U).
- Install stationary seal (Figure 28, item S) in L-gasket.
- Install housing over seal assembly.
- With flush ports facing away from the backplate place seat retainer (Figure 28, item T) on housing.
- Tighten seat retainer in place using four hex screws (Figure 28, item V).

NOTE: Tighten screws evenly until full metal to metal contact is made on backplate and seat retainer.

- Tighten set screws in spring retainer through 1/4" NPT center port in flush housing (Figure 28, item N). Insert plug and tighten.

Backplate Assembly

- Install o-ring in front shims on motor shaft.
- Apply anti-seize or equal compound to motor shaft and install key.
- Install backplate with seal assembly and impeller on motor shaft.
- Position backplate onto adapter with flat surface area above groove. Top mounting screw will be at 12 o'clock position.
- Install clamp and position bolt/nut connection at 7 o'clock allowing easy access to front cover bolts. (Figure 31).

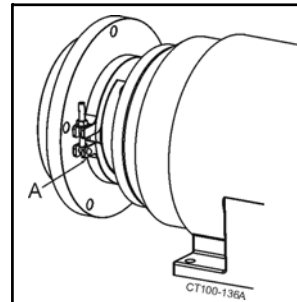

Figure 31 - Clamp Impeller/Backplate to Motor Adapter

- 2065LR:** Assemble spring washers in series, as shown in . Tighten impeller nut.

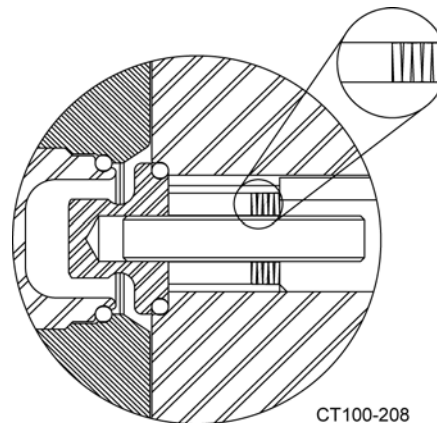

Figure 32 - 2065LR Impeller Retainer Shimming

2085LR: If end of shaft is not flush with impeller counter bore, add .015 shim washers (Figure 34, item A) to end of shaft (Figure 33).

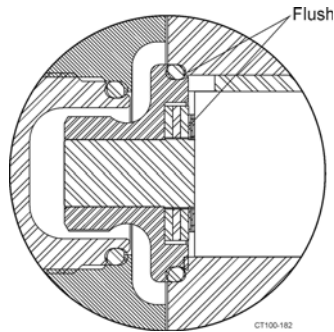

Figure 33 - 2085LR Impeller Retainer Shimming

Assemble three belleville washers to impeller retainer with o-ring (Figure 34, item B, D and C) with curved surfaces opposed to each other. Tighten impeller retainer to bottom out metal-to-metal.

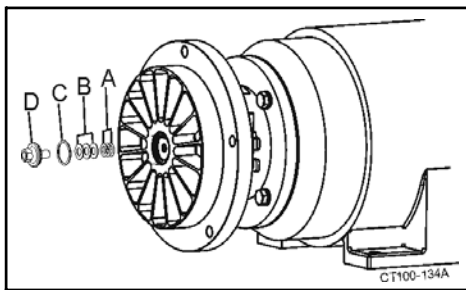

Figure 34 - Install Shims, Belleville Washers and Impeller Retainer with O-Ring

7. Install backplate cover o-ring. (Figure 35, item A).

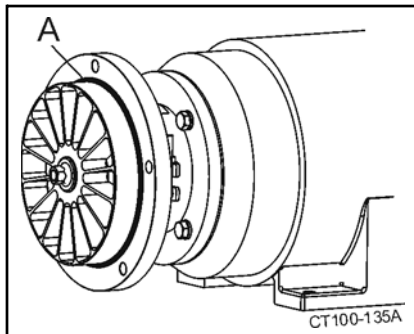

Figure 35 - Install Backplate Cover O-ring

8. Install front cover (Figure 36, item A) on backplate with ports above center of pump.

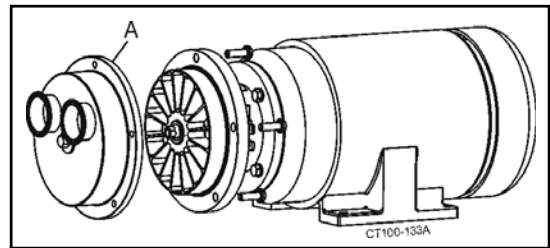

Figure 36 - Install Front Cover

9. Install bolts and washers connecting front cover to backplate (Figure 37).

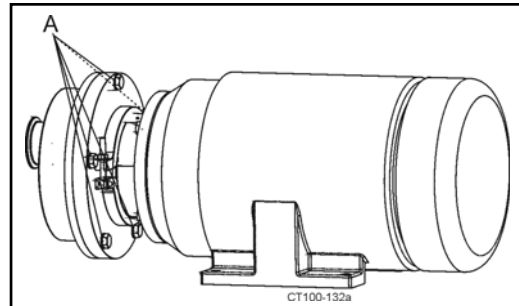

Figure 37 - Install Backplate Bolts

10. Remove impeller inspection plug and confirm operating clearances by manually rotating shaft/impeller ensuring impeller does not touch casing or backplate.

11. Reinstall impeller inspection plug.

Parts Lists

Seal Components All Pumps

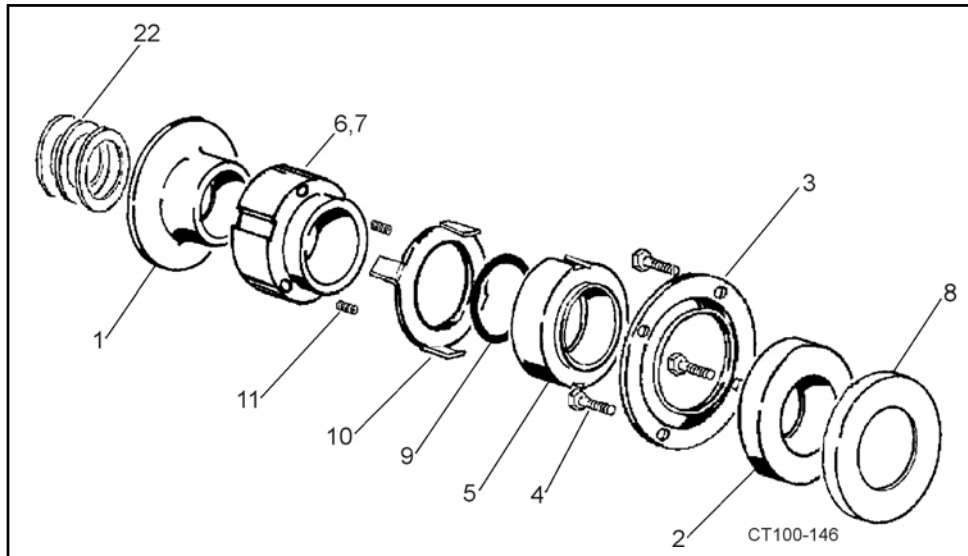

Figure 38 - Type 1 Seal Assembly

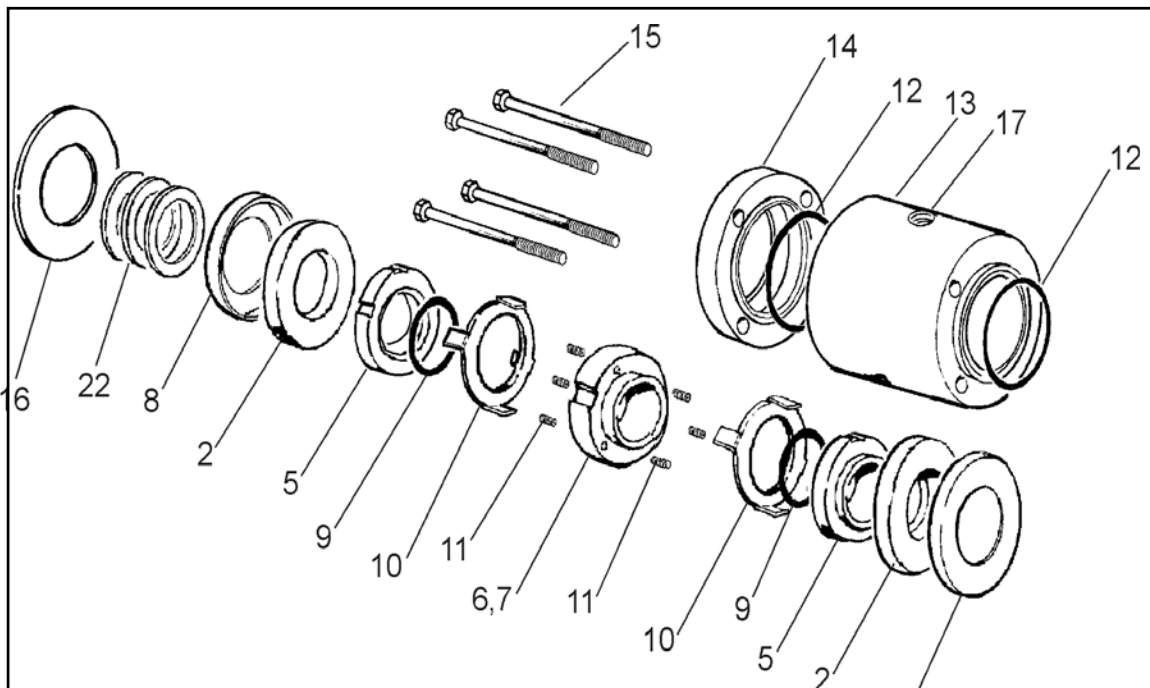

Figure 39 - Type 4 Seal Assembly

ITEM	DESCRIPTION	TYPE 1/1C SEAL QTY	TYPE 4 SEAL QTY	MATERIAL	PART #
1	Deflector	1	-		69-1
2*	Stationary Seal	1	2	Purbide (1.75")	23-17
				S/Carbide (1.75")	23-17A
				Ceramic (1.75")	23-17E
				T/Carbide (1.75")	23-17F
3	Seal Retainer	1	-		23-78
4	Bolt 1/4-20 x 1/2"	4	-		30-62
5*	Rotary Seal	1	2	Carbon (1.75")	9-225A
				Purbide (1.75")	9-225B
				S/Carbide (1.75")	9-225C
				T/Carbide (1.75")	9-225F
6*	Capscrew 1/4-20 x 3/8" (not shown)	2	2		30-178
7*	Spring Retainer (1.75)	1	1		23-77
8*	L-gasket	1	2	Viton®	9-37
				EPDM	9-37E
				Kalrez®	9-37K
				Silicone	9-37R
9*	O-ring	1	2	Viton® (1.75)	V70224
				EPDM (1.75)	E70224
				Chemrez (1.75)	C75224
				Kalrez® (1.75)	K75224
				Silicone (1.75)	S75224
10*	Washer, Tabbed	1	2		43-87
11*	Spring	3	6		24-65
12*	O-ring, Housing	-	2		V70039
13	Housing, Seal	-	1		23-80
14	Retainer, Seat	-	1		23-79
15	Capscrew 1/4-20 x 3"	-	4		30-175
16	Slinger, 142-215JM	-	1		69-4
17	Plug N.P.T. 1/4"	-	1		78-155
20	Plastic Hose 1/4" (not shown)	-	-		74-1
21	Hose Fitting 1/4" (not shown)	-	-		78-18

*Recommended spare parts.

For item 22, see "Motor Shaft Shims" on page 24.

MOTOR SHAFT SHIMS	MOTOR NEMA FRAME SIZE	QTY	PART #
.005" THK.	213JM-215JM	As required.	35-1
.010" THK.	213JM-215JM	As required.	35-2
.020" THK.	213JM-215JM	As required.	35-3
.005" THK.	254JM-326JM	As required.	35-4
.010" THK.	254JM-326JM	As required.	35-5
.020" THK.	254JM-326JM	As required.	35-6

2065LR Self-Priming Pump Parts

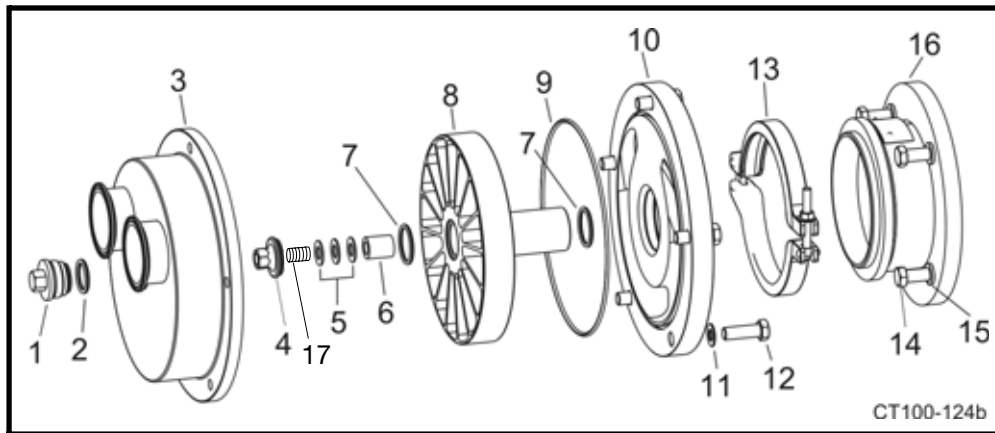

ITEM	DESCRIPTION	QTY	PART #
1	Plug Inspection	1	115162
2	O-ring 215 FDA Viton®	1	V70215
3	Cover Pump	1	120873
4	Nut-Impeller Retainer	1	122456
5	Spring Nut	5	120897
6	Spacer Nut	1	120896
7	O-ring 220 FDA Viton® Impeller Nut	2	V70214
8	Impeller Self-Primer	1	120875
9	O-ring 267 FDA Viton® Cover Seal	1	V70260
10	Backplate	1	120874
11	Plain Washer 1/2" SS Type B Narrow	4	43-233
12	Bolt HHCS 1/2"-13 x 1.5"	4	30-103X
13	Clamp	1	119-87
14	Bolt HHCS 3/8"-16 x .75 18-8	4	30-50
15	Lock Washer 3/8" 18-8	4	43-28
16	Adapter LR85 254/256JM	1	120877
17	Stud LR2065 Pump	1	120898

2085LR Self-Priming Pump Parts

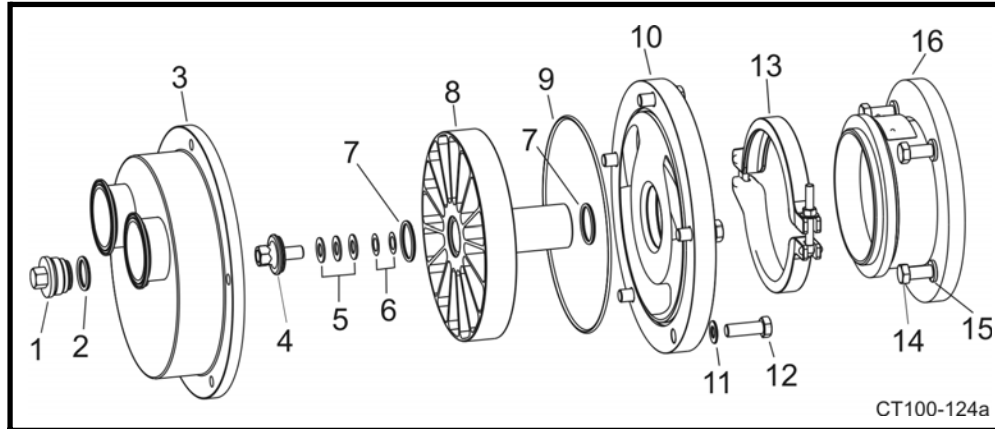

ITEM	DESCRIPTION	QTY	PART #
1	Plug Inspection	1	115162
2	O-ring 215 FDA Viton®	1	V70215
3	Cover Pump	1	115160
4	Nut-Impeller Retainer	1	115163
5	Belleville Washer 1/2" 17-7SS	3	43-243
6	Shim Washer .015" Thick	As required.	43-244
7	O-ring 220 FDA Viton® Impeller Nut	2	V70220
8	Impeller Self-Primer	1	114911
9	O-ring 267 FDA Viton® Cover Seal	1	V70267
10	Backplate	1	115161
11	Plain Washer 1/2" 18-8	5	43-31X
12	Bolt HHCS 1/2"-13 x 1.5"	5	30-103X
13	Clamp	1	119-71
14	Bolt HHCS 1/2"-13 x 1.25 316SS	4	30-36X
15	Lock Washer 1/2" 18-8	4	43-16
16	Adapter LR85 254/256JM	1	115169

Motor Mounts

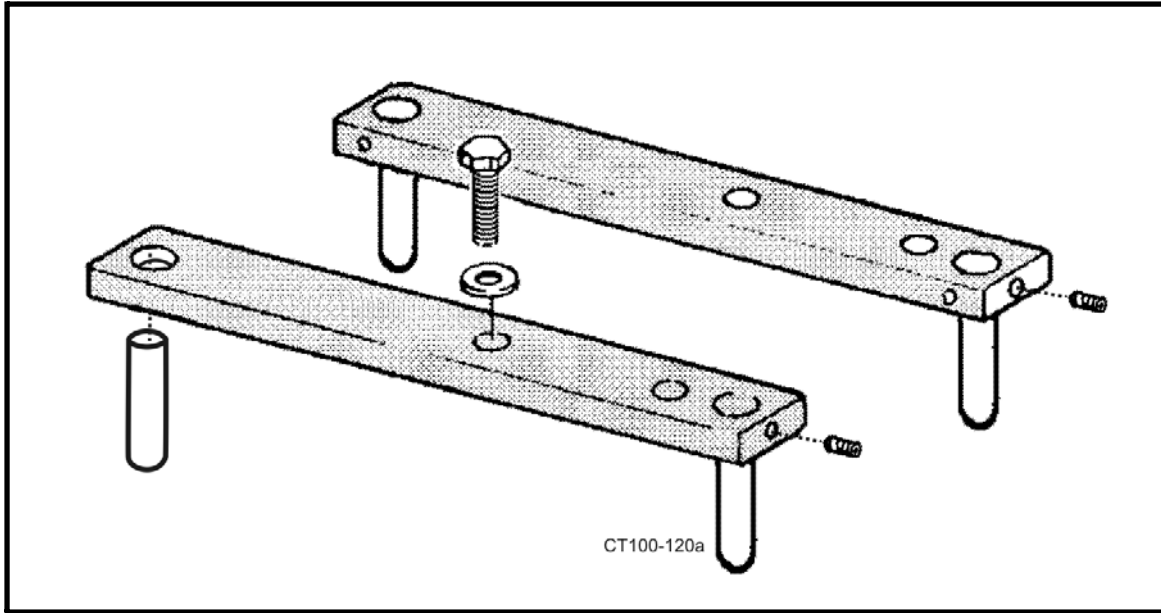

PUMP MODEL	FRAME	LEG KIT
S2065LR	213/215	110254
S2085LR	254/256	110253

Troubleshooting

PROBLEM	POSSIBLE CAUSE	SUGGESTED ACTION
Not Enough Liquid Delivered	Suction or discharge plugged or closed.	Open suction. If plugged shutdown pump and remove blockage.
	Air leak in supply or at seal area.	Check system for air leaks and repair as necessary. Replace seals if necessary.
	Discharge head too high.	Lower discharge head until pump can move material without turning too freely causing overload.
	Suction lift too high.	Lower pump in system until pump is easily supplied with product.
	Speed too slow (low voltage, wrong frequency, wrong motor).	Adjust voltage and frequency. Change motor if necessary.
	Excessive air in material.	Adjust system to remove excess air from material before reaching the pump.
	Insufficient NPSH (Net Positive Suction Head) available.	Adjust system to provide correct NPSH.
Not Enough Pressure	Air leak in supply or at seal area.	Check system for air leaks and repair as necessary. Replace seals if necessary.
	Speed too slow (low voltage, wrong frequency, wrong motor).	Adjust voltage and frequency. Change motor if necessary.
	Excessive air in material.	Adjust system to remove excess air from material before reaching the pump.
Motor Overload	Faulty electrical connections.	Check wiring and repair or replace as necessary.
	Impeller interference.	Disassemble pump and inspect for damage. Remove interference if still present. Replace worn or damaged parts.
	Seal binding.	Disassemble pump and inspect for damage. Check for material crystallization on seals.
	Liquid heavier or more viscous than rating.	Contact your Waukesha Cherry-Burrell Customer Service Representative for sizing information. WCB Customer Service Telephone: 1-800-252-5200 or 262-728-1900
	Overload heaters too small for motor.	Inspect and replace as necessary.
	Electrical supply, voltage and frequency incorrect.	Adjust voltage and frequency. Change motor if necessary.
	Defective motor.	Replace motor.
	Discharge lead too low.	Increase discharge pressure.

PROBLEM	POSSIBLE CAUSE	SUGGESTED ACTION
Vibration/Noise	Pump not level.	Ensure legs are touching floor. Level pump.
	Piping not supported.	Support all piping as described in installation section.
	Starved suction/supply line blocked.	Shutdown pump and remove blockage.
	Foreign material in pump.	Disassemble pump, remove all foreign material and inspect for damage. Replace worn or damaged parts.
	Starved suction/insufficient NPSH (Net Positive Suction Head) available.	Adjust system to provide correct NPSH.
	Impeller out of balance.	Disassemble pump and inspect for damage. Replace impeller.
	Motor bearings worn.	Disassemble motor and inspect for damage. Replace worn parts.
	Starved suction/supply line too long.	Shorten system supply line.
	Starved suction/supply line too small.	Install larger supply lines.
Rapid Seal Wear	Water Hammer.	Adjust system to reduce air in system and sudden starts or stops in flow.
	Abrasive product.	Contact your Waukesha Cherry-Burrell Customer Service Representative for alternate seal information. WCB Customer Service Telephone: 1-800-252-5200 or 262-728-1900
	Prolonged “dry” running.	Adjust process to insure pump has continual fresh supply of product during operation.
	Abrasive solids (unfiltered) in flush water supplied to seal.	Use only filtered water in seal flush system.
Seal Leaks	Gasket damaged or worn.	Replace gasket.
	Seal not installed correctly.	Disassemble pump and inspect seal for damage (replace if necessary). Install seal correctly and reassemble pump.
	Carbon seal worn or damaged.	Replace carbon seal.
	Inlet/outlet connection loose.	Inspect inlet/outlet connection for gasket and tighten connection.