

/ Recold® MW Series Fluid Cooler /

Engineering Data



Closed circuit cooler selections can easily be made by using the information on pages 2 through 7. The examples below demonstrate proper procedures for water and ethylene glycol solutions. Other fluids can be cooled, but since their heat transfer and flow characteristics may vary, please contact your local Recold sales representative for assistance.

WATER SELECTION EXAMPLE

Tower duty: cool 300 GPM of water from 95°F to 85°F at 72°F wet bulb temperature.

1. Determine Range:

95°F - 85°F = 10°F Range

2. Determine Approach:

85°F - 72°F = 13°F Approach

3. Select Load Factor (Table 1):

For 72°F wet bulb, 10°F Range and 13°F Approach, Load Factor = 3.2. (Interpolate between tables for wet bulbs not shown.)

4. Select Unit Model (Table 2):

Since 3.2 load factor falls between 3.0 and 3.5, enter the 3.0 column and read down to the smallest unit flow rating which is greater or equal to 300 GPM. For the model 44C, interpolating between 343 and 271 GPM gives a flow rating of 316 GPM. Since the unit is capable of cooling the design flow at these conditions, the Model 44C is the correct selection. If the interpolated result was still less than design flow, select the next largest model and repeat this procedure.

5. Determine Flow Limitations (Table 2):

For 44C, 300 GPM falls in a High Flow category, so the correct unit selection is a MWH-44C.

6. Determine Coil Pressure Drop (Table 3):

For 300 GPM the pressure drop for a 44C is 2.8 PSI.

ETHYLENE GLYCOL EXAMPLE

Tower duty: cool 68 GPM of 50% ethylene glycol solution in water from 95°F to 85°F at 78°F wet bulb.

1. Determine Range:

95°F - 85°F = 10°F Range

2. Determine Approach:

85°F - 75°F = 7°F Approach

3. Select Load Factor (Table 1):

For 78°F wet bulb, 10°F Range and 7°F Approach, Load Factor = 4.2.

4. Select Unit Model (Table 2):

At a 4.2 load factor, an 18B is the smallest unit that will handle a design flow of 68 GPM.

5. Correct Flow for Ethylene Glycol (Table 8):

The flow correction factor for 68 GPM of 50% glycol is 1.06. 68 GPM x 1.06 = 72 GPM.

6. Adjust Model Selection (Table 2):

Re-enter table 2 to make a selection based on a corrected design flow of 72 GPM. The adjusted unit selection is a 18C.

7. Determine Flow Limitations (Table 2):

For a 18C, 72 GPM falls in a Low Flow category, so the correct unit selection is a MWL-18C.

8. Determine Coil Pressure Drop (Table 3):

For 72 GPM the pressure drop for a 18C is 3.3 PSI.

DEFINITIONS

Range: the difference between the entering and leaving water temperatures (WT in – WT out).

Approach: the difference between the leaving water temperature and the web bulb temperature (WT out – WB).

Load BTUH =

GPM x 500 x Sp. Gr. x Sp. Ht. x (T¹ – T²) where

Sp. Gr. = specific gravity at average temperature

Sp. Ht. = specific heat at average temperature

T¹ = entering temperature

T² = leaving temperature

Closed circuit cooler selections can easily be made by using the information on pages 2 through 7. The examples below demonstrate proper procedures for water and ethylene glycol solutions. Other fluids can be cooled, but since their heat transfer and flow characteristics may vary, please contact your local Recold sales representative for assistance.

WATER SELECTION EXAMPLE

Tower duty: cool 300 GPM of water from 97°F to 87°F at 80°F wet bulb temperature.

1. Determine Range:

97°F - 87°F = 10°F Range

2. Determine Approach:

87°F - 80°F = 7°F Approach

3. Select Load Factor (Table 1):

For 80°F wet bulb, 10°F Range and 7°F Approach, Load Factor = 4.1. (Interpolate between tables for wet bulbs not shown.)

4. Select Unit Model (Table 5):

Since 4.1 load factor falls between 4.0 and 4.2, enter the 4.0 column and read down to the smallest unit flow rating which is greater or equal to 300 GPM. For the model 96B, interpolating between 358 and 330 GPM gives a flow rating of 344 GPM. Since the unit is capable of cooling the design flow at these conditions, the Model 96B is the correct selection. If the interpolated result was still less than design flow, select the next largest model and repeat this procedure.

5. Determine Flow Limitations (Table 5):

For 96B, 300 GPM falls in a Standard Flow category, so the correct unit selection is a MW-96B.

6. Determine Coil Pressure Drop (Table 6):

For 300 GPM the pressure drop for a 96B is 2.95 PSI.

ETHYLENE GLYCOL EXAMPLE

Tower duty: cool 250 GPM of 50% ethylene glycol solution in water from 95°F to 85°F at 78°F wet bulb.

1. Determine Range:

95°F - 85°F = 10°F Range

2. Determine Approach:

85°F - 75°F = 7°F Approach

3. Select Load Factor (Table 1):

For 78°F wet bulb, 10°F Range and 7°F Approach, Load Factor = 4.2.

4. Select Unit Model (Table 5):

At a 4.2 load factor, an MW-64C is the smallest unit that will handle a design flow of 250 GPM.

5. Correct Flow for Ethylene Glycol (Table 8):

The flow correction factor for 250 GPM of 50% glycol is 1.06. 250 GPM x 1.06 = 265 GPM.

6. Adjust Model Selection (Table 5):

Re-enter table 5 to make a selection based on a corrected design flow of 265 GPM. The adjusted unit selection is a 80B.

7. Determine Flow Limitations (Table 5):

For a 80B, 265 GPM falls in a Standard Flow category, so the correct unit selection is a MW-80B.

8. Determine Coil Pressure Drop (Table 6):

For 265 GPM the pressure drop for a 80B is 2.1 PSI.

DEFINITIONS

Range: the difference between the entering and leaving water temperatures (WT in – WT out).

Approach: the difference between the leaving water temperature and the web bulb temperature (WT out – WB).

Load BTUH =

GPM x 500 x Sp. Gr. x Sp. Ht. x (T¹ – T²) where

Sp. Gr. = specific gravity at average temperature

Sp. Ht. = specific heat at average temperature

T¹ = entering temperature

T² = leaving temperature

Recold / MW Series Fluid Cooler / Load Factors

TABLE NO. 1

60° WET BULB

		RANGE																	
		6	8	10	12	14	16	18	20	22	24	26	28	30	32	34	36	38	40
APPROACH	7				6.0	6.4	6.7	7.2	7.3	7.5	7.7	7.9	8.0	8.2					
	8				5.6	6.0	6.4	6.7	6.9	7.1	7.3	7.5	7.6	7.8	7.9	8.0			
	9		4.3	4.8	5.3	5.7	6.0	6.3	6.5	6.8	6.9	7.1	7.3	7.4	7.6	7.7	7.8	7.9	8.0
	10		4.0	4.5	5.0	5.4	5.7	6.0	6.2	6.4	6.6	6.8	6.9	7.1	7.3	7.4	7.5	7.6	7.8
	11		3.8	4.3	4.7	5.0	5.3	5.6	5.9	6.1	6.3	6.5	6.6	6.8	6.9	7.0	7.2	7.3	7.4
	12	2.9	3.5	4.0	4.5	4.8	5.1	5.4	5.6	5.8	6.0	6.2	6.4	6.5	6.6	6.8	6.9	7.0	7.2
	13	2.8	3.2	3.8	4.2	4.5	4.9	5.1	5.4	5.6	5.8	5.9	6.2	6.3	6.4	6.5	6.7	6.8	6.9
	14	2.5	3.1	3.6	4.0	4.3	4.6	4.9	5.1	5.3	5.5	5.7	5.9	6.0	6.2	6.3	6.4	6.6	6.8
	15	2.4	3.0	3.5	3.9	4.1	4.5	4.7	4.9	5.2	5.4	5.5	5.7	5.8	6.0	6.1	6.3	6.4	6.6
	16	2.3	2.8	3.3	3.7	4.0	4.3	4.6	4.8	4.9	5.1	5.3	5.5	5.6	5.7	5.9	6.1	6.3	6.4
	17	2.2	2.7	3.2	3.6	3.9	4.1	4.4	4.6	4.8	4.9	5.1	5.3	5.4	5.7	5.8	5.9	6.0	6.2
	18	2.1	2.6	3.0	3.6	3.8	4.0	4.2	4.4	4.6	4.8	4.9	5.1	5.3	5.4	5.6	5.8	5.9	6.0
	19	2.0	2.5	2.9	3.3	3.6	3.9	4.1	4.3	4.5	4.7	4.8	4.9	5.2	5.3	5.4	5.6	5.8	5.9
	20	1.9	2.4	2.8	3.2	3.4	3.7	3.9	4.2	4.3	4.5	4.7	4.8	4.9	5.1	5.3	5.4	5.6	5.7
	21	1.9	2.4	2.7	3.1	3.4	3.6	3.9	4.1	4.2	4.4	4.6	4.7	4.9	5.0	5.3	5.3	5.4	5.6
	22	1.8	2.3	2.6	3.0	3.2	3.5	3.7	3.9	4.1	4.3	4.4	4.6	4.7	4.9	5.0	5.2	5.3	5.4
	23	1.8	2.3	2.6	3.0	3.2	3.5	3.7	3.9	4.1	4.3	4.4	4.6	4.7	4.8	5.0	5.2	5.3	5.4
	24	1.7	2.1	2.5	2.8	3.1	3.3	3.5	3.7	3.9	4.1	4.3	4.4	4.5	4.6	4.8	4.9	5.1	5.2
	25	1.6	2.1	2.4	2.7	3.0	3.2	3.4	3.6	3.8	3.9	4.1	4.2	4.4	4.6	4.7	4.8	4.9	5.1
	26	1.6	2.0	2.3	2.6	2.9	3.2	3.3	3.5	3.7	3.9	4.0	4.1	4.3	4.4	4.6	4.7	4.8	4.9
	27	1.5	2.0	2.3	2.6	2.8	3.1	3.3	3.4	3.6	3.8	3.9	4.1	4.2	4.3	4.4	4.6	4.7	4.8
	28	1.5	1.9	2.2	2.5	2.8	3.0	3.2	3.4	3.5	3.7	3.8	4.0	4.1	4.2	4.3	4.4	4.6	4.7
	29	1.4	1.8	2.1	2.4	2.7	2.9	3.1	3.3	3.4	3.6	3.7	3.9	4.0	4.1	4.2	4.4	4.5	4.6
	30	1.4	1.8	2.1	2.4	2.6	2.8	3.0	3.2	3.3	3.5	3.6	3.8	3.9	4.0	4.1	4.3	4.4	4.5

62° WET BULB

		RANGE																	
		6	8	10	12	14	16	18	20	22	24	26	28	30	32	34	36	38	40
APPROACH	7						5.8	6.3	6.6	6.9	7.1	7.3	7.5	7.7	7.9	8.1			
	8						4.9	5.4	5.8	6.2	6.5	6.7	6.9	7.1	7.3	7.4	7.6	7.8	8.0
	9		4.1	4.6	5.0	5.4	5.8	6.0	6.4	6.5	6.7	6.9	7.0	7.2	7.3	7.5	7.6	7.8	7.9
	10		3.8	4.3	4.8	5.1	5.5	5.8	6.0	6.2	6.4	6.6	6.8	6.9	7.0	7.2	7.3	7.4	7.6
	11	3.0	3.6	4.2	4.6	4.9	5.2	5.5	5.7	6.0	6.2	6.3	6.5	6.7	6.8	7.0	7.1	7.2	7.3
	12	2.8	3.5	4.0	4.4	4.7	5.0	5.3	5.5	5.7	5.9	6.1	6.3	6.4	6.5	6.7	6.8	7.0	7.1
	13	2.7	3.3	3.7	4.1	4.5	4.8	5.1	5.3	5.5	5.7	5.9	6.0	6.2	6.3	6.5	6.6	6.8	6.9
	14	2.5	3.1	3.5	3.9	4.3	4.6	4.8	5.0	5.2	5.5	5.6	5.8	5.9	6.1	6.2	6.3	6.5	6.7
	15	2.2	2.9	3.3	3.7	4.1	4.3	4.6	4.8	5.0	5.2	5.4	5.5	5.7	5.8	6.0	6.1	6.3	6.4
	16	2.2	2.8	3.0	3.6	3.9	4.2	4.4	4.6	4.8	5.1	5.2	5.4	5.5	5.7	5.8	6.0	6.1	6.3
	17	2.1	2.7	3.1	3.5	3.8	4.1	4.3	4.5	4.7	4.9	5.0	5.2	5.4	5.5	5.7	5.8	6.0	6.1
	18	2.1	2.5	3.0	3.4	3.7	3.9	4.2	4.4	4.5	4.7	4.9	5.0	5.2	5.3	5.5	5.6	5.8	5.9
	19	2.0	2.4	2.9	3.2	3.5	3.8	4.0	4.2	4.4	4.6	4.7	4.9	5.0	5.2	5.3	5.4	5.6	5.8
	20	1.9	2.3	2.8	3.1	3.4	3.6	3.9	4.1	4.2	4.4	4.6	4.7	4.9	5.0	5.2	5.3	5.5	5.6
	21	1.8	2.3	2.7	3.0	3.3	3.5	3.8	4.0	4.1	4.3	4.5	4.6	4.8	4.9	5.1	5.2	5.3	5.5
	22	1.8	2.2	2.6	2.9	3.2	3.4	3.7	3.9	4.0	4.2	4.4	4.5	4.7	4.8	4.9	5.1	5.2	5.4
	23	1.7	2.1	2.5	2.8	3.1	3.3	3.5	3.7	3.9	4.1	4.3	4.4	4.5	4.7	4.8	4.9	5.1	5.2
	24	1.6	2.1	2.5	2.7	3.0	3.2	3.4	3.6	3.8	4.0	4.1	4.3	4.4	4.6	4.7	4.8	5.0	5.1
	25	1.6	2.0	2.4	2.6	2.9	3.1	3.3	3.5	3.7	3.9	4.0	4.2	4.3	4.5	4.6	4.7	4.8	5.0
	26	1.5	2.0	2.3	2.6	2.8	3.1	3.3	3.4	3.6	3.8	3.9	4.1	4.2	4.4	4.5	4.6	4.7	4.9
	27	1.5	1.9	2.2	2.5	2.8	3.0	3.2	3.4	3.6	3.7	3.9	4.0	4.1	4.3	4.4	4.5	4.6	4.7
	28	1.5	1.8	2.2	2.4	2.7	2.9	3.1	3.3	3.5	3.6	3.7	3.9	4.0	4.2	4.3	4.4	4.5	4.6
	29	1.4	1.8	2.1	2.3	2.6	2.8	3.0	3.2	3.4	3.5	3.6	3.8	3.9	4.1	4.2	4.3	4.4	4.5
	30	1.4	1.7	2.0	2.3	2.5	2.8	3.0	3.2	3.4	3.5	3.6	3.8	3.9	4.1	4.2	4.3	4.4	4.5

64° WET BULB

		RANGE																	
		6	8	10	12	14	16	18	20	22	24	26	28	30	32	34	36	38	40
APPROACH	7				5.6	6.1	6.4	6.7	7.0	7.1	7.4	7.5	7.7	7.8	8.0				
	8			4.8	5.3	5.6	6.0	6.3	6.6	6.8	7.0	7.1	7.3	7.5	7.6	7.7	7.8	7.9	8.0
	9		3.9	4.5	4.9	5.3	5.6	5.9	6.2	6.4	6.6	6.7	6.9	7.1	7.2	7.3	7.5	7.6	7.7
	10		3.7	4.3	4.7	5.0	5.3	5.6	5.9	6.1	6.3	6.5	6.6	6.8	6.9	7.0	7.1	7.3	7.5
	11	2.9	3.5	4.1	4.5	4.9	5.1	5.4	5.6	5.8	6.0	6.2	6.3	6.5	6.7	6.8	6.9	7.0	7.2
	12	2.7	3.4	3.9	4.3	4.6	4.9	5.1	5.4	5.6	5.8	6.0	6.1	6.3	6.4	6.6	6.7	6.8	7.0
	13	2.6	3.2	3.6	4.0	4.4	4.6	4.9	5.2	5.4	5.5	5.7	5.9	6.0	6.2	6.3	6.5	6.6	6.8
	14	2.4	3.0	3.4	3.8	4.2	4.4	4.7	4.9	5.1	5.3	5.5	5.7	5.8	5.9	6.1	6.2	6.4	6.6
	15	2.2	2.8	3.2	3.6	4.0	4.2	4.5	4.7	4.9	5.0	5.2	5.4	5.6	5.7	5.9	6.0	6.1	6.3
	16	2.1	2.7	3.1	3.5	3.8	4.1	4.3	4.5	4.7	4.9	5.1	5.3	5.4	5.5	5.7	5.9	6.0	6.1
	17	2.1	2.6	3.0	3.4	3.7	4.0	4.2	4.4	4.6	4.7	4.9	5.1	5.3	5.4	5.6	5.7	5.8	6.0
	18	2.0	2.5	2.9	3.3	3.6	3.8	4.1	4.3	4.4	4.6	4.8	4.9	5.1	5.2	5.4	5.5	5.7	5.8
	19	1.9	2.4	2.8	3.1	3.4	3.7	3.9	4.1	4.3	4.5	4.6	4.8	4.9	5.1	5.2	5.3	5.5	5.7
	20	1.8	2.3	2.7	3.0	3.3	3.5	3.8	4.0	4.1	4.3	4.5	4.6	4.8	4.9	5.1	5.2	5.4	5.5
	21	1.8	2.2	2.6	2.9	3.2	3.4	3.7	3.9	4.0	4.2	4.4	4.5	4.7	4.8	5.0	5.1	5.2	5.4
	22	1.8	2.1	2.5	2.8	3.1	3.3	3.6	3.8	3.9	4.1	4.3	4.4	4.6	4.7	4.8	5.0	5.1	5.3
	23	1.7	2.1	2.4	2.7	3.0	3.3	3.6	3.8	4.0	4.1	4.3	4.4	4.6	4.7	4.8	5.0	5.1	5.2
	24	1.6	2.0	2.4	2.7	2.9	3.2	3.3	3.5	3.7	3.9	4.0	4.2	4.3	4.5	4.6	4.7	4.9	5.0
	25	1.6	1.9	2.3	2.6	2.8	3.1	3.2	3.4	3.6	3.8	3.9	4.1	4.2	4.4	4.5	4.6	4.7	4.9
	26	1.5	1.9	2.2	2.5	2.7	3.0	3.2	3.3	3.5	3.7	3.8	4.0	4.1	4.3	4.4	4.5	4.6	4.8
	27	1.5	1.8	2.1	2.4	2.7	2.9	3.1	3.3	3.5	3.6	3.7	3.9	4.0	4.2	4.3	4.4	4.5	4.6
	28	1.4	1.8	2.1	2.3	2.6	2.8	3.0	3.2	3.4	3.5	3.6	3.8	3.9	4.1	4.2	4.3	4.4	4.5
	29	1.4	1.7	2.0	2.3	2.5	2.8	2.9	3.1	3.3	3.4	3.5	3.7	3.8	4.0	4.1	4.2	4.3	4.4
	30	1.3	1.6	1.9	2.2	2.4	2.7	2.9	3.0	3.2	3.3	3.4	3.6	3.7	3.9	4.0	4.1	4.2	4.3

66° WET BULB

		RANGE																	
		6	8	10	12	14	16	18</											

Recold / MW Series Fluid Cooler / Load Factors

TABLE NO. 1

72° WET BULB

		RANGE																	
		6	8	10	12	14	16	18	20	22	24	26	28	30	32	34	36	38	40
APPROACH	7	4.1	4.7	5.1	5.5	5.9	6.1	6.4	6.6	6.8	7.0	7.1	7.3	7.4	7.6	7.7	7.8	7.9	
	8	3.1	3.8	4.3	4.8	5.1	5.5	5.7	6.0	6.2	6.4	6.6	6.7	6.9	7.0	7.1	7.3	7.4	7.5
	9	2.9	3.5	4.1	4.4	4.8	5.1	5.4	5.6	5.8	6.0	6.1	6.4	6.5	6.6	6.7	6.9	7.0	7.1
	10	2.7	3.3	3.8	4.2	4.5	4.8	5.1	5.3	5.5	5.7	5.9	6.0	6.2	6.3	6.5	6.6	6.7	6.9
	11	2.5	3.1	3.6	4.0	4.3	4.6	4.9	5.1	5.3	5.5	5.7	5.8	6.0	6.1	6.3	6.4	6.5	6.7
	12	2.4	2.9	3.4	3.8	4.1	4.4	4.7	4.9	5.1	5.3	5.5	5.6	5.7	5.8	6.0	6.2	6.3	6.5
	13	2.3	2.8	3.2	3.6	4.0	4.2	4.5	4.7	4.9	5.1	5.2	5.4	5.5	5.7	5.8	5.9	6.1	6.3
	14	2.1	2.6	3.1	3.4	3.8	4.0	4.3	4.5	4.6	4.8	5.0	5.1	5.3	5.4	5.6	5.7	5.9	6.1
	15	2.0	2.5	2.9	3.2	3.6	3.8	4.1	4.3	4.4	4.6	4.8	4.9	5.1	5.2	5.4	5.5	5.7	5.9
	16	1.9	2.4	2.8	3.1	3.5	3.7	3.9	4.1	4.3	4.5	4.6	4.8	4.9	5.1	5.2	5.4	5.5	5.7
	17	1.9	2.3	2.7	3.0	3.3	3.6	3.8	4.0	4.2	4.3	4.5	4.7	4.8	4.9	5.1	5.2	5.4	5.6
	18	1.8	2.2	2.6	2.9	3.2	3.5	3.7	3.9	4.0	4.2	4.4	4.5	4.7	4.8	5.0	5.1	5.2	5.4
	19	1.7	2.1	2.5	2.8	3.1	3.3	3.6	3.7	3.9	4.1	4.2	4.4	4.5	4.7	4.8	4.9	5.1	5.2
	20	1.6	2.0	2.4	2.7	3.0	3.2	3.4	3.6	3.8	3.9	4.1	4.2	4.4	4.5	4.7	4.8	4.9	5.1
	21	1.6	2.0	2.3	2.6	2.9	3.1	3.2	3.5	3.7	3.8	4.0	4.1	4.3	4.4	4.5	4.7	4.8	4.9
	22	1.5	1.9	2.2	2.5	2.8	3.0	3.2	3.4	3.6	3.7	3.9	4.0	4.2	4.3	4.4	4.5	4.7	4.8
	23	1.4	1.8	2.2	2.4	2.7	2.9	3.1	3.3	3.5	3.7	3.8	3.9	4.1	4.2	4.3	4.4	4.5	4.7
	24	1.4	1.8	2.1	2.4	2.6	2.8	3.0	3.2	3.4	3.5	3.7	3.8	3.9	4.0	4.2	4.3	4.4	4.5
	25	1.3	1.7	2.0	2.3	2.5	2.7	2.9	3.1	3.3	3.4	3.6	3.7	3.8	3.9	4.0	4.2	4.3	4.4
	26	1.3	1.7	2.0	2.2	2.4	2.6	2.8	3.0	3.2	3.3	3.5	3.6	3.7	3.8	3.9	4.1	4.2	4.3
	27	1.2	1.6	1.9	2.1	2.4	2.6	2.8	2.9	3.1	3.2	3.4	3.5	3.6	3.7	3.9	4.0	4.1	4.2
	28	1.2	1.5	1.8	2.1	2.3	2.5	2.7	2.9	3.0	3.2	3.3	3.4	3.6	3.7	3.8	3.9	4.0	4.1
	29	1.2	1.5	1.7	2.0	2.2	2.4	2.6	2.8	2.9	3.1	3.2	3.3	3.5	3.6	3.7	3.8	3.9	4.0
	30	1.1	1.4	1.7	1.9	2.1	2.3	2.5	2.6	2.8	3.0	3.1	3.2	3.4	3.5	3.6	3.7	3.8	3.9

74° WET BULB

		RANGE																	
		6	8	10	12	14	16	18	20	22	24	26	28	30	32	34	36	38	40
APPROACH	7	4.0	4.5	5.0	5.4	5.7	6.0	6.3	6.4	6.7	6.8	7.0	7.2	7.3	7.4	7.5	7.7	7.8	7.9
	8	3.0	3.7	4.2	4.7	5.0	5.3	5.6	5.8	6.0	6.2	6.4	6.6	6.7	6.8	6.9	7.1	7.3	7.4
	9	2.8	3.4	3.9	4.3	4.7	4.9	5.2	5.4	5.6	5.9	6.0	6.2	6.4	6.5	6.6	6.8	6.9	7.0
	10	2.6	3.1	3.7	4.1	4.4	4.7	4.9	5.1	5.4	5.6	5.8	5.9	6.0	6.2	6.3	6.4	6.6	6.8
	11	2.5	3.0	3.5	3.9	4.2	4.5	4.7	4.9	5.2	5.4	5.5	5.7	5.8	6.0	6.1	6.2	6.4	6.6
	12	2.3	2.9	3.3	3.7	4.0	4.3	4.5	4.7	4.9	5.1	5.3	5.4	5.6	5.7	5.9	6.0	6.2	6.4
	13	2.2	2.7	3.2	3.5	3.8	4.1	4.3	4.6	4.7	4.9	5.1	5.2	5.4	5.5	5.7	5.8	6.0	6.1
	14	2.1	2.6	3.0	3.4	3.7	3.9	4.1	4.4	4.5	4.7	4.9	5.0	5.2	5.3	5.5	5.6	5.8	5.9
	15	2.0	2.4	2.8	3.2	3.5	3.7	3.9	4.2	4.3	4.5	4.7	4.8	5.0	5.1	5.3	5.4	5.6	5.7
	16	1.9	2.3	2.7	3.1	3.4	3.6	3.8	4.0	4.2	4.3	4.5	4.7	4.8	5.0	5.1	5.3	5.4	5.6
	17	1.8	2.2	2.6	3.0	3.2	3.5	3.7	3.9	4.1	4.2	4.4	4.5	4.7	4.8	5.0	5.1	5.3	5.4
	18	1.7	2.2	2.5	2.8	3.1	3.4	3.6	3.8	4.0	4.1	4.3	4.4	4.6	4.7	4.8	5.0	5.1	5.2
	19	1.7	2.1	2.4	2.7	3.0	3.2	3.5	3.7	3.8	4.0	4.1	4.3	4.4	4.6	4.7	4.8	4.9	5.1
	20	1.6	2.0	2.3	2.6	2.9	3.1	3.3	3.5	3.7	3.8	4.0	4.1	4.3	4.4	4.5	4.7	4.8	4.9
	21	1.5	1.9	2.3	2.5	2.8	3.0	3.2	3.4	3.6	3.7	3.9	4.0	4.2	4.3	4.4	4.6	4.7	4.8
	22	1.5	1.9	2.2	2.5	2.7	2.9	3.1	3.3	3.5	3.6	3.8	3.9	4.1	4.2	4.3	4.4	4.5	4.6
	23	1.4	1.8	2.1	2.4	2.6	2.9	3.1	3.2	3.4	3.5	3.7	3.8	3.9	4.1	4.2	4.3	4.4	4.5
	24	1.3	1.7	2.0	2.3	2.5	2.8	3.0	3.1	3.3	3.4	3.6	3.7	3.8	3.9	4.1	4.2	4.3	4.4
	25	1.3	1.7	2.0	2.2	2.4	2.7	2.9	3.0	3.2	3.3	3.5	3.6	3.7	3.8	3.9	4.1	4.2	4.3
	26	1.2	1.6	1.9	2.2	2.4	2.6	2.8	2.9	3.1	3.2	3.4	3.5	3.6	3.7	3.8	4.0	4.1	4.2
	27	1.2	1.6	1.8	2.1	2.3	2.5	2.7	2.9	3.0	3.1	3.3	3.4	3.5	3.6	3.7	3.8	3.9	4.0
	28	1.2	1.5	1.8	2.0	2.2	2.4	2.6	2.8	2.9	3.1	3.2	3.3	3.5	3.6	3.7	3.8	3.9	4.0
	29	1.1	1.4	1.7	1.9	2.1	2.4	2.5	2.7	2.9	3.0	3.1	3.3	3.4	3.5	3.6	3.7	3.8	3.9
	30	1.1	1.4	1.6	1.9	2.1	2.3	2.4	2.6	2.8	2.9	3.0	3.2	3.3	3.4	3.5	3.6	3.7	3.8

76° WET BULB

		RANGE																	
		6	8	10	12	14	16	18	20	22	24	26	28	30	32	34	36	38	40
APPROACH	7	3.8	4.3	4.8	5.2	5.5	5.6	6.1	6.2	6.5	6.6	6.8	7.0	7.1	7.2	7.3	7.5	7.6	7.7
	8	2.9	3.5	4.0	4.5	4.8	5.1	5.4	5.6	5.8	6.0	6.2	6.4	6.5	6.6	6.7	6.9	7.0	7.2
	9	2.7	3.3	3.8	4.2	4.5	4.8	5.1	5.3	5.5	5.7	5.9	6.0	6.2	6.3	6.5	6.6	6.8	6.9
	10	2.5	3.0	3.5	4.0	4.2	4.6	4.8	5.0	5.2	5.4	5.6	5.7	5.9	6.0	6.2	6.3	6.5	6.6
	11	2.4	2.9	3.4	3.8	4.1	4.4	4.6	4.8	5.0	5.2	5.4	5.5	5.7	5.8	6.0	6.1	6.3	6.4
	12	2.2	2.8	3.2	3.6	3.9	4.2	4.4	4.6	4.8	5.0	5.2	5.3	5.5	5.6	5.8	5.9	6.1	6.2
	13	2.1	2.6	3.1	3.4	3.7	4.0	4.2	4.5	4.6	4.8	5.0	5.1	5.3	5.4	5.6	5.7	5.9	6.0
	14	2.0	2.5	2.9	3.3	3.6	3.8	4.0	4.3	4.4	4.6	4.8	4.9	5.1	5.2	5.4	5.5	5.7	5.8
	15	1.8	2.3	2.7	3.1	3.4	3.6	3.8	4.1	4.2	4.4	4.6	4.7	4.9	5.0	5.2	5.3	5.5	5.6
	16	1.8	2.2	2.6	3.0	3.3	3.5	3.7	3.9	4.1	4.2	4.4	4.6	4.7	4.9	5.0	5.2	5.3	5.4
	17	1.7	2.1	2.5	2.9	3.1	3.4	3.6	3.8	4.0	4.1	4.3	4.4	4.6	4.7	4.9	5.0	5.2	5.3
	18	1.6	2.1	2.4	2.7	3.0	3.3	3.5	3.7	3.8	4.0	4.2	4.3	4.5	4.6	4.7	4.9	5.0	5.1
	19	1.6	2.0	2.3	2.6	2.9	3.1	3.4	3.6	3.7	3.9	4.0	4.2	4.3	4.5	4.6	4.7	4.8	4.9
	20	1.5	1.9	2.2	2.5	2.8	3.0	3.2	3.4	3.6	3.7	3.9	4.0	4.2	4.3	4.4	4.6	4.7	4.8
	21	1.5	1.8	2.2	2.4	2.7	2.9	3.1	3.3	3.5	3.6	3.8	3.9	4.1	4.2	4.3	4.5	4.6	4.7
	22	1.4	1.8	2.1	2.4	2.6	2.8	3.0	3.2	3.4	3.5	3.7	3.8	4.0	4.1	4.2	4.3	4.4	4.5
	23	1.4	1.7	2.0	2.3	2.5	2.8	3.0	3.1	3.3	3.4	3.6	3.7	3.8	4.0	4.1	4.2	4.3	4.4
	24	1.3	1.6	1.9	2.2	2.4	2.7	2.9	3.0	3.2	3.3	3.5	3.6	3.7	3.8	4.0	4.1	4.2	4.3
	25	1.3	1.6	1.9	2.1	2.3	2.6	2.8	2.9	3.1	3.2	3.4	3.5	3.6	3.7	3.8	4.0	4.1	4.2
	26	1.2	1.5	1.8	2.1	2.3	2.5	2.7	2.8	3.0	3.1	3.3	3.4	3.5	3.6	3.7	3.9	4.0	4.1
	27	1.2	1.5	1.8	2.0	2.2	2.4	2.6	2.8	2.9	3.1	3.2	3.3	3.4	3.5	3.7	3.8	3.9	4.0
	28	1.2	1.5	1.7	1.9	2.1	2.3	2.5	2.7	2.8	3.0	3.1	3.2	3.4	3.5	3.6	3.7	3.8	3.9
	29	1.1	1.4	1.6	1.8	2.1	2.3	2.5	2.7	2.8	2.9	3.0	3.2	3.3	3.4	3.5	3.6	3.7	3.8
	30	1.1	1.4	1.6	1.8	2.0	2.2	2.4	2.5	2.7	2.8	2.9	3.1	3.2	3.3	3.4	3.5	3.6	3.7

78° WET BULB

|--|--|

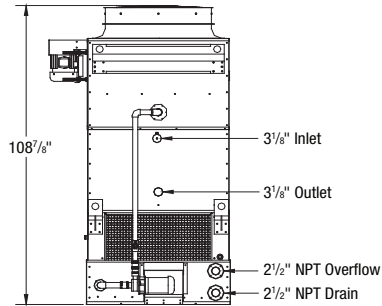

Connection Elevation

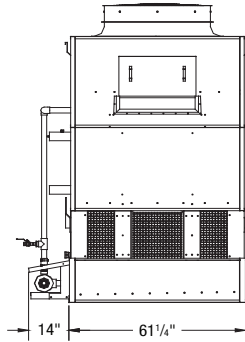

Side Elevation MW18A-MW18C

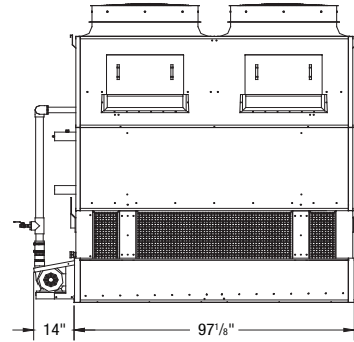

Side Elevation MW30A-MW30C

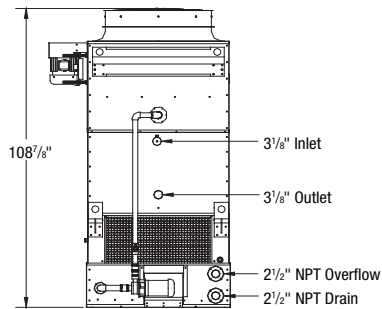

Connection Elevation

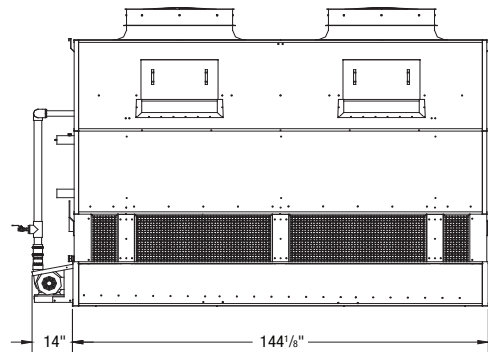

Side Elevation MW44-MW44C

TABLE NO. 9: Schematic

Note: Use this bulletin for preliminary layouts only.
Obtain current drawing from your Recold sales representative.

Model No.	Fan		Pump Motor hp	Dimensions			Weights lb		Remote Sump gallons required	Coil Volume gallons
	Motor hp	Air Volume cfm		Height	Length	Width	Shipping	Operating		
18A	5	12,600	1	108 7/8"	61 1/4"	49 3/4"	1,540	2,660	105	33
18B	5	12,300	1	108 7/8"	61 1/4"	49 3/4"	1,640	2,830	105	42
18C	5	11,800	1	108 7/8"	61 1/4"	49 3/4"	1,730	3,000	105	50
30A	(2) 3	19,500	1	108 7/8"	97 1/8"	49 3/4"	2,360	4,150	175	51
30B	(2) 3	19,000	1	108 7/8"	97 1/8"	49 3/4"	2,510	4,420	175	66
30C	(2) 3	18,500	1	108 7/8"	97 1/8"	49 3/4"	2,680	4,720	175	80
44A	(2) 5	32,400	1 1/2	108 7/8"	144 1/8"	49 3/4"	3,030	5,700	270	75
44B	(2) 5	30,300	1 1/2	108 7/8"	144 1/8"	49 3/4"	3,270	6,100	270	97
44C	(2) 5	29,000	1 1/2	108 7/8"	144 1/8"	49 3/4"	3,500	6,550	270	120

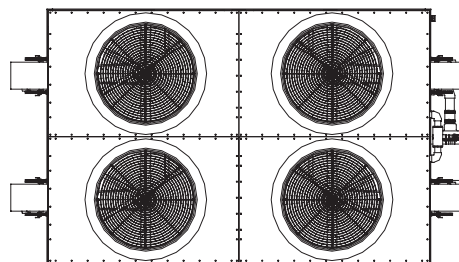

Plan View

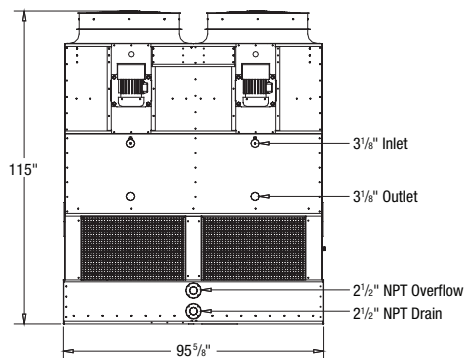

Connection Elevation

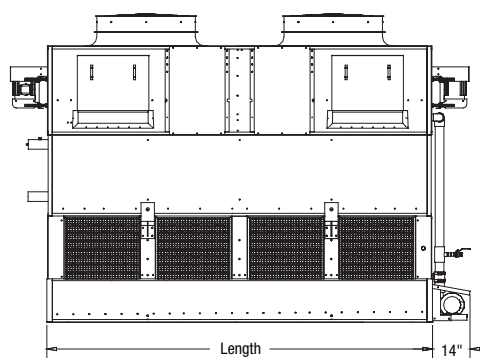

Side Elevation

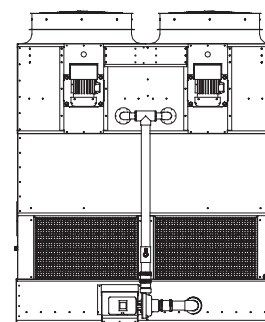

Pump Elevation

TABLE NO. 10: Schematic

Note: Use this bulletin for preliminary layouts only.
Obtain current drawing from your Recold sales representative.

Model No.	Fan		Pump Motor hp	Dimensions			Weights lb		Remote Sump gallons required	Coil Volume gallons
	Motor hp	Air Volume cfm		Height	Length	Width	Shipping	Operating		
64B	(4) 5	48,000	2	115"	97 1/8"	95 5/8"	5,070	8,890	350	132
64C	(4) 5	46,500	2	115"	97 1/8"	95 5/8"	5,410	9,490	350	160
80B	(4) 5	53,400	2	115"	120 5/8"	95 5/8"	5,840	10,610	445	163
80C	(4) 5	51,900	2	115"	120 5/8"	95 5/8"	6,240	11,330	445	200
96B	(4) 5	58,800	3	115"	144 1/8"	95 5/8"	6,600	12,330	540	66
96C	(4) 5	57,200	3	115"	144 1/8"	95 5/8"	7,070	13,170	540	240

Furnish _____ Recold model MW-_____ induced draft closed circuit fluid cooler(s). Each tower shall have the capacity to cool _____ GPM of _____ from _____ °F to _____ °F at _____ °F entering web bulb temperature.

Heat Transfer Coil: The heat exchange coil tubes shall be constructed of copper to provide maximum corrosion resistance. Coil tubes shall be 5/8" OD copper tubing with type L headers. Tubes shall be supported by stainless steel tube sheets with high temperature plastic inserts for long life. The completed coil section shall be leak tested under water at 350 psig.

Mechanical Equipment: A high-quality bearing assembly, specifically designed for cooling tower service shall be provided. Bearings will be greased at the factory with extended lubelines provided. The fan shaft shall be stainless steel. Fans shall be low sound, axial propeller type with GRP blades for high-efficiency and long life. V-belt drive shall be designed for 150% of motor horsepower. Belt adjustment shall be accomplished from the exterior of the unit. Each fan section shall have dividers to allow the fans to be cycled individually.

Fan Motor: Fan motor shall be minimum ___hp ___ RPM open drip-proof type designed for outdoor service with 1.15 service factor on ___ volts, ___ phase, and ___ hertz. All motors shall be mounted outside the tower with a protective rain cover included.

Water Distribution: System shall be designed to evenly and completely distribute the spray water over the coil. Spray nozzles shall be PVC large orifice, non-clogging design, attached to PVC headers with stainless steel clamps. Nozzle spray pattern shall be a full 360 degrees for maximum distribution. Internal piping and fittings shall be made entirely of schedule 40 PVC for maximum corrosion protection.

Water Recirculation Pumps: The water recirculation pump shall be close-coupled, centrifugal type with mechanical seal. A minimum ___ hp open drip-proof type pump motor designed for outdoor service with a 1.15 service factor suitable for service on ___ volts, ___ phase, and ___ hertz shall be provided. Drift Eliminators: The drift eliminator sections shall be sub assembled from PVC for easy handling. Drift eliminator shall incorporate three changes of air direction with maximum drift rate less than 0.001 % of the circulating water rate.

Louvers: The louver sections shall be sub assembled from PVC for easy handling. Louvers shall incorporate three changes in air direction to prevent water splash out and block direct sunlight. Each louver subassembly shall be easily removed with two screws for basin access.

Pan and Casing: The evaporative fluid cooler shall be constructed of a stainless steel sump pan and G-235 heavy mill galvanized casing panels. All panels shall be flanged outward for greater rigidity and to eliminate connecting fasteners from penetrating inside the tower wet section. The pan bottom shall be sloped design to allow for easy draining and cleaning. At least one access door to the top section shall be provided for easy inspection and service. The access door shall be made from stainless steel and operate without any gasket or fasteners.

OPTIONAL COMPONENTS

Sump Pan Heater

A Sump Pan Heater package including a low watt-density, screw-plug immersion heater(s), a thermostat mounted within a NEMA 4 enclosure, and a low-water cutout switch mounted within a NEMA 4 enclosure shall be installed on the unit sump pan for wiring by others. The Sump Pan Heater package shall provide 40°C sump pan water temperature at a -10°C outside ambient temperature when the Fluid Cooler is not in operation. Heater contactor must be supplied by others unless Recold Control-Starter Panel is included.

Control-Starter Panel

A factory installed and tested Control-Starter Panel shall consist of fan and pump motor starters, disconnect switch, control transformer (if needed), and a submersible bulb Aquastat. All components shall be factory wired in a NEMA 3R enclosure and shall have U.L. label certification. The panel shall be mounted on the unit and have the unit fans and pump motors factory wired to the panel, allowing for single-point connection to customer's power supply. The Sump Pan Heater package shall be wired and a contactor shall be installed in the factory provided Control-Starter Panel.

Furnish _____ Recold model MW-_____ induced draft closed circuit fluid cooler(s). Each tower shall have the capacity to cool _____ GPM of _____ from _____ °F to _____ °F at _____ °F entering web bulb temperature.

Heat Transfer Coil: The heat exchange coil tubes shall be constructed of copper to provide maximum corrosion resistance. Coil tubes shall be 5/8" OD copper tubing with type L headers. Tubes shall be supported by stainless steel tube sheets with high temperature plastic inserts for long life. The completed coil section shall be leak tested under water at 350 psig.

Mechanical Equipment: A high-quality bearing assembly, specifically designed for cooling tower service shall be provided. Bearings will be greased at the factory with extended lubelines provided. The fan shaft shall be stainless steel. Fans shall be low sound, axial propeller type with GRP blades for high-efficiency and long life. V-belt drive shall be designed for 150% of motor horsepower. Belt adjustment shall be accomplished from the exterior of the unit. Each fan section shall have dividers to allow the fans to be cycled individually.

Fan Motor: Fan motor shall be minimum 4-5 hp 1800 RPM open drip-proof type designed for outdoor service with 1.15 service factor on ___ volts, ___ phase, and ___ hertz. All motors shall be mounted outside the tower with a protective rain cover included.

Water Distribution: System shall be designed to evenly and completely distribute the spray water over the coil. Spray nozzles shall be PVC large orifice, non-clogging design, attached to PVC headers with stainless steel clamps. Nozzle spray pattern shall be a full 360 degrees for maximum distribution. Internal piping and fittings shall be made entirely of schedule 40 PVC for maximum corrosion protection.

Water Recirculation Pumps: The water recirculation pump shall be close-coupled, centrifugal type with mechanical seal. A minimum 3 hp open drip-proof type pump motor designed for outdoor service with a 1.15 service factor suitable for service on ___ volts, ___ phase, and ___ hertz shall be provided. Drift Eliminators: The drift eliminator sections shall be sub assembled from PVC for easy handling. Drift eliminator shall incorporate three changes of air direction with maximum drift rate less than 0.001 % of the circulating water rate.

Louvers: The louver sections shall be sub assembled from PVC for easy handling. Louvers shall incorporate three changes in air direction to prevent water splash out and block direct sunlight. Each louver subassembly shall be easily removed with two screws for basin access.

Pan and Casing: The evaporative fluid cooler shall be constructed of a stainless steel sump pan and G-235 heavy mill galvanized casing panels. All panels shall be flanged outward for greater rigidity and to eliminate connecting fasteners from penetrating inside the tower wet section. The pan bottom shall be sloped design to allow for easy draining and cleaning. At least one access door to the top section shall be provided for easy inspection and service. The access door shall be made from stainless steel and operate without any gasket or fasteners.

OPTIONAL COMPONENTS

Stainless Steel Casing

The unit(s) shall be provided with all sump pan sides, floor panels, coil supports, anti-cavitation hood, swirl arrestor, upper casing panels and access doors constructed out of series 300 stainless steel.

Chemical Water Treatment System

Unit(s) shall be provided with a factory installed and piped at the factory Chemical Water Treatment System consisting of one Nu-Calgon CMS IV microprocessor controlled Conductivity Controller and Chemical Metering Pump in a NEMA 4X style enclosure and solenoid valve, along with factory designed and installed piping system to control TDS levels and bleed rates.

For the most part, evaporative closed circuit coolers will be installed for operation on a year-round basis. Units installed in a cold climate must be provided with adequate freeze protection for both the recirculating water and the heat exchange coil for proper equipment operation.

RECIRCULATING WATER

The operation of evaporative cooled equipment under approximately full load conditions will prevent freezing of the recirculated water. However, during periods of very little or no heat load when fans and pumps are shut down, some form of freeze protection must be used.

A simple form of freeze protection commonly used is a remote sump tank inside a heated building below the evaporative cooled equipment. The water circulation pump is located at the remote tank circulating water through the evaporative cooler during load conditions. When the unit is shut down, the water drains down into the remote sump tank which is in a heated atmosphere.

The remote sump installation may be unacceptable in some cases due to unit location or space limitations. For these applications, pan water freeze protection may be attained by means of an optional electric heater located inside the unit pan. Electric pan heaters are designed to prevent pan water freezing during unit shut down with fans and pumps idle.

Water lines to and from the unit, pump, pump discharge and drain lines must be wrapped with a heat-tracing element and insulated to protect them from freezing.

Safety: The M Series is designed for routine maintenance to be performed from the base of the unit's exterior, eliminating the need for permanent access to the top. The upper horizontal surface is not intended for use as a working platform. Specific reference to the safety of personnel performing maintenance and inspection procedures can be found in the Operation and Maintenance instructions.

HEAT EXCHANGE COIL

The best means of heat exchanger coil freeze protection is to circulate an ethylene glycol water solution. The solution freeze points with respective ethylene glycol by volume are given in Table 11 below. This method will allow freeze protection irrespective of heat load or unit shut down.

If glycol cannot be used, other means of freeze protection must be used and the following rules strictly adhered to.

1. Maintain full flow through the coil
2. Maintain heat load on the coil at all time so that the leaving water temperature does not drop below +50°F

Full flow alone will not protect the coil. Temperature of +50°F must also be maintained.

Units operating in low ambient conditions with a heat load which becomes very low or drops off completely may require the addition of an artificial load to maintain safe fluid temperature.

The above methods of coil freeze protection, when properly applied and maintained will provide good equipment protection. All methods, other than those using an adequate antifreeze solution, should provide a means of emergency coil draining. It is recommended that automatic drain valves and air vents with vacuum breakers be installed on each coil circuit. Adequately size drains with heat-tracing tape and insulation should be provided for free drainage. Should the circulating pump fail or the water temperature leaving the coil drop below 50°F for any reason, the coil will automatically drain preventing freeze damage.

TABLE NO. 11: Solution Freeze Points by Volume

Freeze Point °F	Ethylene Glycol (by volume)			
	20%	30%	40%	50%
	14	3	-14	-38



COOLING TECHNOLOGIES

RECORD PRODUCTS
 550 W MERCURY LANE
 BREA, CALIFORNIA 92821
 UNITED STATES
 714 529 6080
 spxcooling@spx.com
spxcooling.com

In the interest of technological progress, all products are subject to design and/or material change without notice.
 ©2008 SPX Cooling Technologies, Inc.
 Printed in USA | RECORD MW TS-07