

Recold® JT Series Cooling Tower

Engineering Data



JT Series Cooling Tower / Construction

Recold, the pioneer of Dri-Fan forced draft evaporative coolers, now applies this principal to the cooling of process water. With the fan in the supply air stream, away from the high humidity air leaving the tower, the fan shaft and bearing are assured longer life.

SYSTEM

The process water enters the spray tree at the top of the unit, is sprayed down onto the heat exchanger surface or "fill," giving up heat to the counterflowing air before returning to the system from the sump pan. Moist air does not enter the fan assembly, resulting in longer life and fewer service problems.

HYDROSPRAY NOZZLES

Hydrospray nozzles are made of non-ferrous material, sized and spaced for optimum wetting of fill. The even distribution of spray across the fill material is extremely important in evaporative equipment.

ACCESSIBILITY

Recold cooling towers are designed for maximum accessibility for inspection and cleaning. Recold patented access doors on both sides of the unit provide ample access to the spray nozzles, fill, eliminators, bleeds and sump pan for service and maintenance. Recold access doors provide a complete air and water tight seal without gaskets or fasteners, and are "quick opening."

CONSTRUCTION

Recold cooling towers are constructed of 300 series stainless steel (basin, fill supports and access doors) and heavy gauge hot dipped G-235 galvanized steel per ASTM A-525.

BLOWERS

A single, slow-speed forward curve blower is used for optimum efficiency and minimum noise. Each blower is balanced to eliminate unit vibration on Recold's high precision electronic balancing equipment. Large blowers are made from galvanized steel and subject to careful quality control throughout. Fan shafts are coated to prevent corrosion. The blower drives are selected at 150% of rated brake horsepower.

Bearings are self-aligning, ball-bearing type, with external lubricating fittings and selected for 2000,000 hour average bearing life. Rugged, OSHA approved, belt guard and screen are provided for protection. Motor is mounted on an adjustable base.

INTEGRATED ASSEMBLY

Recold cooling towers are completely assembled at the factory and shipped as a unit.

FILL

High efficiency is accomplished by using a PVC fill design that provides the maximum amount of wetted surface within allowable airside pressure drop. Fill is conveniently sized for easy removal. The cooling tower fill shall be high efficiency, self-extinguishing PVC, a minimum of 40 mils thick. It shall have a flame spread rating of 25 per ASTM standard E-84 and be impervious to rot, decay, fungus or biological attack.

DRIFT ELIMINATORS

Eliminators are constructed of PVC assembled in removable, easy to handle sections. A three-pass design allows three changes in air flow resulting in decreased drift rates. The use of durable PVC eliminates the corrosion problems associated with galvanized eliminators.

TESTING

All Recold cooling towers are tested under the close supervision of the Quality Control Department before being released for shipment. Fans are run and spray systems operated to assure quiet, balanced operation without leaks, water carryover or vibration. Nozzles are checked for proper distribution.

Use this data for preliminary layouts only. Obtain current drawing from your Marley/Recold sales representative.

The UPDATE web-based selection software—available at spxcooling.com—provides JT Series model recommendations based on customer's specific design requirements.

JT Series Cooling Tower / Schematic

Model	Dimensions inches									Access Doors				Sump gallons note 4
										Far Side		Near Side		
	A	B	C note 2	D	H	J	K	R	Top	Bottom	Top	Bottom		
JT1830	80	76	31	84	—	6	53	61¼	1	1	—	—	43	
JT2140	96	76	37	102	—	6	65	61	1	1	—	—	64	
JT2550 - JT2565	115¼	77	45¼	124	51¼	6	76¼	65	1	1	1	1	95	
JT3175 - JT3185	139½	80¼	55½	144	51	6	92	67	1	1	1	1	163	
JT31100	139½	80¼	55½	144	51	6	92	67	1	1	1	1	163	
JT37110 - JT37130	172¼	92½	66½	180¼	71¼	6	115	71	2	1	2	1	248	
JT37140	172¼	92½	66½	180¼	71¼	6	115	71	2	1	2	1	248	
JT40160 - JT40180	184¼	98½	93¼	192	84½	8	115	78	2	1	2	1 note 1	374	
JT40215 - JT40240	208	98½	93¾	217	96½	8	139¼	78	2	1	2	1 note 1	454	
JT40265	208	98½	93¾	217	96½	8	139¼	78	2	1	2	1 note 1	454	
JT49290 - JT49310	221	118½	100½	225	80	10	139½	102	2	2	2	2 note 1	748	
JT49340 - JT49360	245½	118½	100½	248	104	10	164½	102	2	2	2	2 note 1	880	
JT49390 - JT49415	268	118½	100½	273	128	10	188	102	2	2	2	2 note 1	1012	

Note

- 1 An additional bottom access door is installed on inlet connection end.
- 2 Overall width of unit at base rail is **C** plus 1".
- 3 Maximum overall height at blower (fan) section is 118".
4. Water level at top of overflow stand pipe
- 5 Discharge duct flange is **C** minus 3" and **K** minus 3".

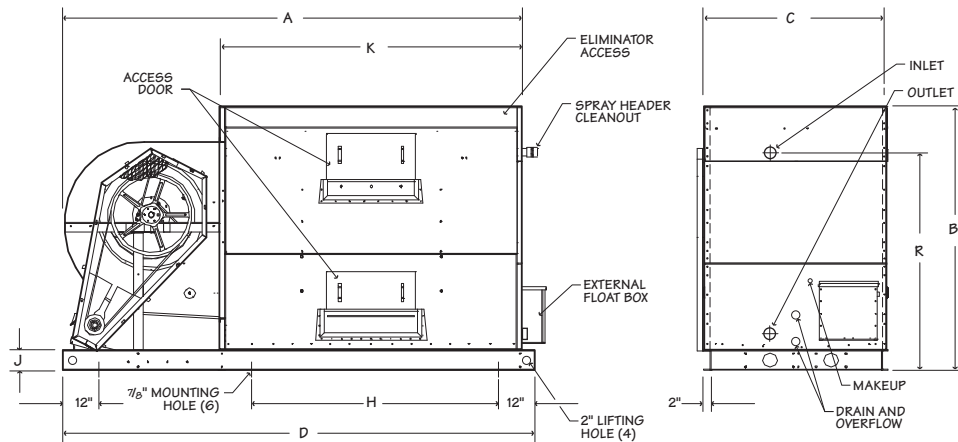

Model	JT	1830	2140	2550	2565	3175	3185	31100	37100	37130	37140	40160	40180	40215	40240	40265	49290	49310	49340	49360	49390	49415
Nominal Tons†		26	36	47	57	73	83	92	113	130	142	164	178	195	212	232	264	280	300	325	340	364
Supply FPT		½	½	½	½	¾	¾	¾	1	1	1	1¼	1¼	1¼	1¼	1¼	1¼	1¼	1¼	1¼	1¼	1¼
Drain FPT		3	3	3	3	3	3	3	3	3	3	3	3	3	3	5	5	5	5	5	5	5
Inlet MPT		2½	3	3	4	4	4	(2)3	(2)4	(2)4	(2)4	(2)4	(2)4	(2)4	(2)4	(2)5	(2)5	(2)5	(2)5	(2)6	(2)6	(2)6
Outlet MPT		4	4	6	6	6	6	6	6	6	6	6	6	6	6	8	8	8	8	8	8	8
Fan Diameter		18	21	25	25	31	31	31	37	37	37	40	40	40	40	49	49	49	49	49	49	49
Fan RPM		625	600	430	500	350	400	462	360	410	445	385	415	385	415	430	243	267	246	271	253	278
Fan CFM		5880	8060	10800	13300	15700	17100	20200	24000	27300	29700	39100	42500	45100	47200	50300	55500	61000	64500	71000	74200	84500
Motor hp* (0"=¼" SP)		2	3	3	5	5	7.5	10	10	15	20	20	25	20	25	30	25	30	30	40	40	50
Motor Frame		145T	182T	184T	184T	213T	215T	215T	254T	254T	256T	284T	256T	284T	286T	284T	284T	286T	286T	324T	324T	326T
Shipping Weight lb		853	1142	1597	1616	2504	2528	2557	3906	3943	3988	5133	5194	5579	5675	5709	7886	7916	8486	8624	8978	9028
Operating Weight lb**		1210	1675	2390	2410	3870	3900	3915	5980	6010	6060	8250	8310	9365	9460	9500	14120	14150	15820	16000	17410	17460

† Nominal tons are based upon 95°F HW, 85°F CW, 78°F WB and 3 GPM/ton. The **UPDATE** web-based selection software provides JT model recommendations based on specific design requirements.

* For static pressure from ¼" to ½" ESP, use next size larger motor.

** At normal operating water level in cold water basin.

Note: All piping connections are for standard GPM. Consult Recold for other flow rates.

JT Series Cooling Tower / Accessories

CAPACITY CONTROLS

Dual Fan Motors—The dual fan motor package is available as a proven energy saving capacity control option. It consists of furnishing a high efficiency motor, a 1200 RPM, low speed motor, two sets of drives and belts, extended fan shaft and motor bases on opposite sides of the blower. A UL control-starter panel is available as a completely wired package for one point connection.

Variable Speed Drive—A Variable Speed Drive automatically minimize the tower's noise level during periods of reduced load and/or reduced ambient temperature without sacrificing the system's ability to maintain a constant cold water temperature. This is a relatively inexpensive solution, and can pay for itself quickly in reduced energy costs.

Electric Damper Controls—An electric damper control package is available as an accessory for modulating the internal damper system. A proportional solid state actuator is factory mounted below the fan scroll and attached to the damper shaft by connecting linkage. A sensing bulb connected to the actuator by a capillary tube is normally mounted in the unit pan water basin for monitoring the system. However, when specified, a pressure control may be supplied for field mounting to allow direct head pressure control. An end switch located inside the motor actuator may be adjusted to cycle the fan motor on for pressure rise and off when dampers close.

CASING INSULATION

In order to further reduce the heat loss from the unit coil, factory installed insulation on exterior coil panels is available. A protective coat of paint is applied to the insulation for protection from the weather elements.

CONTROL – STARTER PANEL

Contains the fan motor starter, disconnect switch, thermostat sensing the cold water temperature to control the fan motor and control transformer when required by the supply power characteristics. All components are contained in a NEMA 12 enclosure with UL label and mounted on the unit. Fan motor and controls are factory wired to the panel to provide single point connection for users power supply.

Panels for dual fan-motor arrangement include elapsed time meters for both motors to aid in determining energy savings. NEMA 3R and 4 enclosures are also available.

VIBRATION ISOLATORS

Spring type vibration isolator rails may be supplied for field installation—some units will require base frame structural support.

ELECTRONIC WATER LEVEL CONTROL

The electronic water level control package provides a constant and accurate means of monitoring water level in the unit. For this reason, it is often recommended for those installations which require year round operation in low ambient conditions.

The complete package includes an electric float switch with stilling chamber which is factory installed in the pan section of the unit. An electric solenoid valve for water make-up is shipped loose for remote installation. All wiring must be provided in the field by others.

PAN HEATER

The use of a remote sump tank located indoors is a common form of pan water freeze protection for evaporative cooling equipment. However, for those installations which will not allow this type of system, freeze protection may be provided by electric immersion heaters or steam or hot water coils installed in the pan.

The electric heater package consists of immersion heaters installed in the pan to provide efficient even heat distribution. Standard heaters are selected to provide approximately 40°F pan water at -10°F ambient temperature. A low water cutout switch is supplied to prevent heater operation when the elements are not completely submerged. The heaters are monitored by a sump thermostat with remote sensing bulb located in the pan water. All heaters and controls are factory installed for field wiring by others.

NOTE: Pan heater packages are designed to prevent pan water freezing during unit shutdown with fans and pump idle.

STAINLESS STEEL CONSTRUCTION

In addition to the standard stainless steel basin, fill supports and access doors, 300 stainless steel construction is offered as an option for upper casing panels.



RECOLD
550 W MERCURY LANE
BREA, CA USA 92821
714 529 6080
spxcooling@spx.com
spxcooling.com

In the interest of technological progress,
all products are subject to design and/or
material change without notice.
©2011 SPX | Printed in USA
RECOLD JT-TECH-07A