

Plenty Mirrlees Pumps

THE HEART OF THE SYSTEM

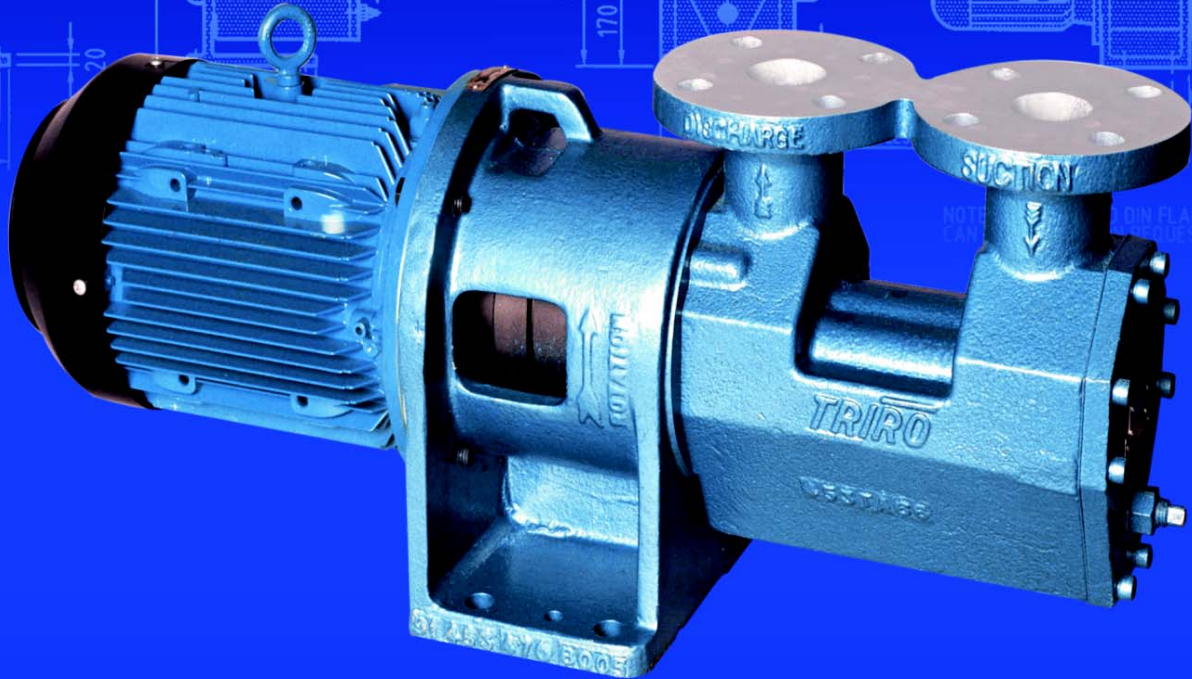

TRIRO

Range: 0 - 16.5 Bar
Models: T45-3 to T60-3

THREE SCREW PUMP

Specification

Body cast in high grade iron.

Screwset, power rotor of carbon steel and idlers of high grade iron.

Mechanical Seal fitted as standard.

Easily adjusted Relief Valve constructed integrally with the pump body.

Suction & Discharge flanged to ASA 125 as standard.

Free standing horizontal and tank top units available, close coupled to AC Motors if required.

Submerged tank mounted units also available.

Principal Characteristics

| **SILENT**

| **VIBRATION FREE**

| **PULSE FREE OPERATION**

| **HIGH SUCTION LIFT**

| **MECHANICAL SEAL**

| **INTEGRAL RELIEF VALVE**

| **VERSATILE INSTALLATION**

| **PRECISION BUILT**

| **HIGH EFFICIENCY**

Packaging - Processing

Bid on Equipment

1-847-683-7720

www.bid-on-equipment.com

T - Range T45-3 to T60-3

T - Range T45-3 to T60-3

DIMENSIONS T45-3 TO T60-3 FOOT & PEDESTAL MOUNTED

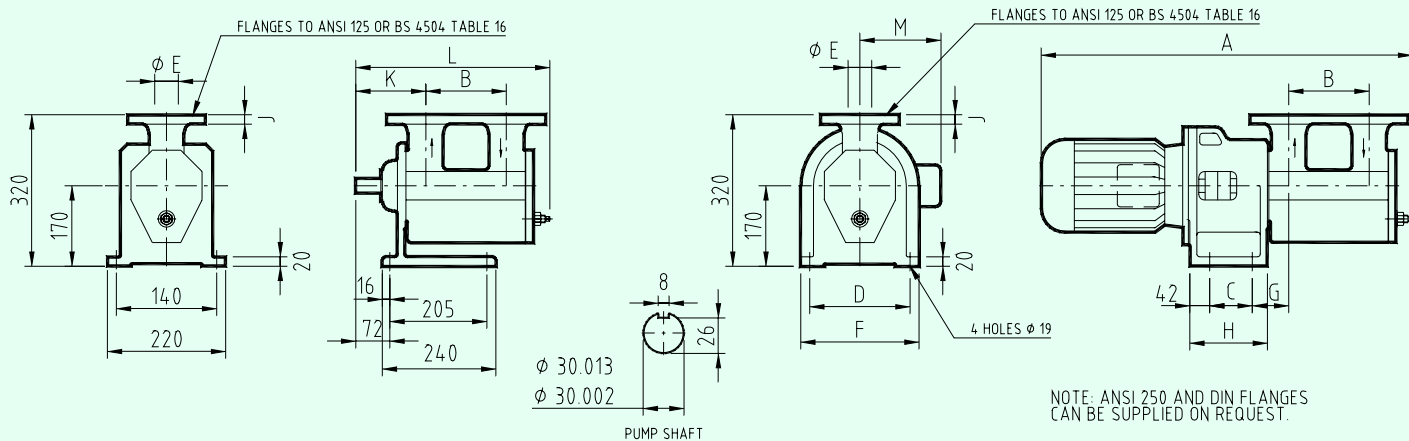

PUMP SIZE	MOTOR FRAME	Approximate dimensions (mm). DO NOT use for installation purposes.											
		A	B	C	D	E	F	G	H	J	K	L	M
T45-3	100LD	776	170	90	212	50 (2")	250	77	164	20	148	401	154
	112MD	789											167
	132SD	856		100	220		260	87	184				188
	132MD												
T52-3	100LD	812	190	90	212	63 (2.5")	250	82	164	20	153	440	154
	112MD	825											167
	132SD	895		100	220		260	92	184				188
	132MD												
T60-3	100LD	842	206	90	212	76 (3")	250	88	164	22	160	471	154
	112MD	855											167
	132SD	925		100	220		260	98	184				188
	132MD												

(Approx dimensions only. Certified drawings supplied with order)

PERFORMANCE DATA

Viscosity cSt	Pressure Bar	Pump Size RPM	T45-3				T52-3				T60-3			
			Normal		Short		Normal		Short		Normal		Short	
			1450	2900	1450	2900	1450	2900	1450	2900	1450	2900	1450	2900
35	5	L/Min	101	219	80.2	174	159	341	126	271	250	530	198	422
		kW	1.3	2.7	1.00	2.2	1.9	4.1	1.5	3.3	2.9	6.4	2.35	5.1
	15	L/Min	89.3	207	69.9	164	143	325	113	258	228	508	179	404
		kW	3.2	6.6	2.6	5.3	4.9	10.2	3.9	8.1	7.6	15.7	6.1	12.6
150	5	L/Min	110	228	87.5	181	170	352	136	281	265	546	211	436
		kW	1.5	3.4	1.2	2.8	2.3	5.3	1.9	4.2	3.6	8.2	2.9	6.5
	15	L/Min	104	222	82.5	176	163	344	129	274	254	535	202	427
		kW	3.5	7.4	2.8	5.9	5.3	11.3	4.3	9.1	8.2	17.5	6.6	14.0
750	5	L/Min	114	232	91.2	185	176	358	141	286	273	-	218	443
		kW	2.0	4.8	1.6	3.9	3.1	7.4	2.5	5.9	4.7	-	3.8	9.2
	15	L/Min	111	229	89.0	183	173	354	138	283	269	-	214	438
		kW	4.0	8.8	3.2	7.0	6.1	13.5	4.9	10.8	9.4	-	7.5	16.6

Pumps can also be selected for 60 Hz motor supply.

These are typical performances figures used as examples only. Full data for performance at other viscosities and pressures available on request.

Operation Three screw pump with one, central, power driven rotor intermeshing with idler rotors, balanced and machined to effect a seal for the liquid being pumped.

Plenty Mirrlees Pumps

Plenty Mirrlees Pumps, Earl Haig Road, Hillington, Glasgow G52 4JN, Scotland, UK.
 Telephone: 0141 883 0314 (Int: 44 141 883 0314) Facsimile: 0141 882 2752 (Int: 44 141 882 2752)
 Email: pumps.plenty@processequipment.spx.com Website: www.plentymirrleespumps.com