

Plenty Mirrlees Pumps

THE HEART OF THE SYSTEM



TRIRO

Range: 0 - 50 Bar
Models: C38-4 to C80-4

Specification

Sleeve in aluminium Alloy as standard, high grade iron option also available.

Screw set, power rotor of carbon steel and idlers of high grade iron.

Mechanical seal fitted as standard.

Easily adjusted relief valve can be fitted to the pump body.

Suction & Discharge flanges to SAE3000.

Most major petroleum specifications catered for i.e. API610, API614, API676 etc.

Principal Characteristics

- | **SILENT**
- | **VIBRATION FREE**
- | **PULSE FREE OPERATION**
- | **GOOD SUCTION**
- | **MECHANICAL SEAL OPTIONS**
- | **VERSATILE INSTALLATION**
- | **PRECISION BUILT**
- | **ULTIMATE RELIABILITY**
- | **ALUMINIUM ALLOY**
- | **HIGH EFFICIENCY**
- | **STAND ALONE CARTRIDGE**
- | **OR FITTED IN IRON/STEEL BODY**
- | **CUSTOMISED TO YOUR SPECIFICATION**

STANDARD INSERT SHOWN WITH SUCTION CHAMBER (CA)

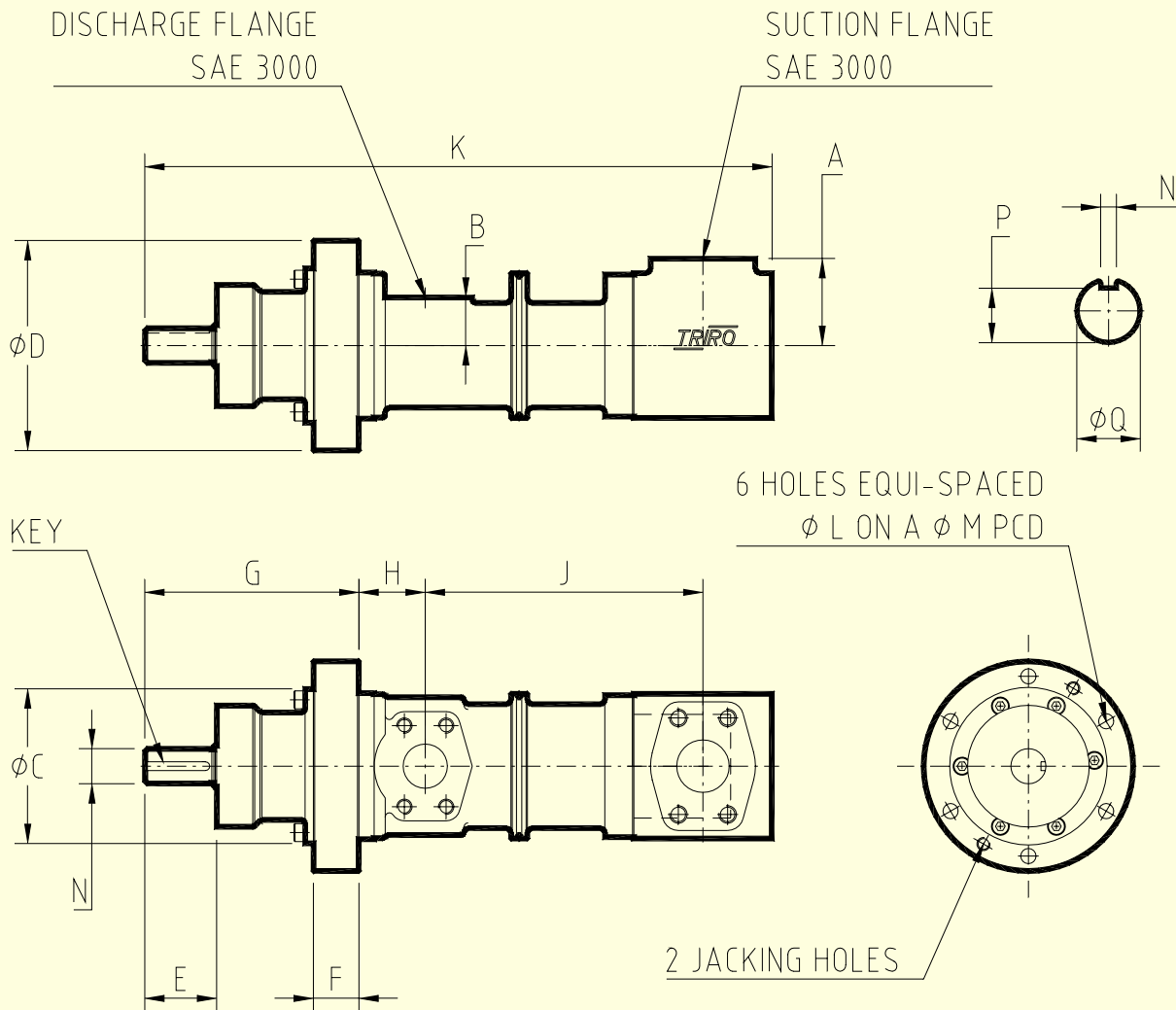

SUCTION PORT CAN BE ROTATED THROUGH 90° INTERVALS WHEN LOOKING ON BACK OF PUMP.

ROTATION: - CLOCKWISE LOOKING ON DRIVE END

END SUCTION CAN BE PROVIDED AS AN OPTIONAL ALTERNATIVE.

	FLANGES		Approximate dimensions (mm). DO NOT use for installation purposes.											SHAFT				
	SUCTION	DISCHARGE	A	B	C	D	E	F	G	H	J	K	L	M	N	P	Q	KEY
C 38-4	1 1/2" N.B.	1 1/4" N.B.	63	35	111.91 111.90	152	52	33	155	48	201	457	11	130	6.350 6.323	21.780 21.650	25.410 25.388	1/4" SQ. x 47 LG.
C 45-4	2" N.B.	1 1/2" N.B.	67	38	131.00 130.975	182	82	34	187	49	238	532	14	152	6.350 6.310	24.970 24.820	28.580 28.570	1/4" SQ. x 62 LG.
C 52-4	2 1/2" N.B.	2" N.B.	70	48	150.00 149.97	201	87	34	207	65	259	594	14	175	9.525 9.500	33.10 33.00	38.100 38.088	3/8" SQ. x 81 LG.
C 60-4	3" N.B.	2" N.B.	78	53	153.00 152.975	217	96	35	216	65	315	674	18	180	9.525 9.500	33.10 33.00	38.100 38.088	3/8" SQ. x 91 LG.
C 70-4	3 1/2" N.B.	2 1/2" N.B.	92	62	179.00 178.975	243	104	35	234	78	352	753	18	205	12.73 12.70	40.46 40.31	47.625 47.609	1/2" SQ. x 98 LG.
C 80-4	4" N.B.	3" N.B.	97	67	200.00 199.971	270	126	35	264	92	406	861	18	230	12.73 12.70	40.46 40.31	47.625 47.609	1/2" SQ. x 105 LG.

Dimensions are based upon 'Plenty Mirrlees Pumps' standard pump construction and may change in order to meet individual customer specifications.

DO NOT USE FOR FINAL INSTALLATION DIMENSIONS
Certified drawings available upon request..

MOUNTING ARRANGEMENT OR CUSTOMISED TO MEET YOUR NEEDS

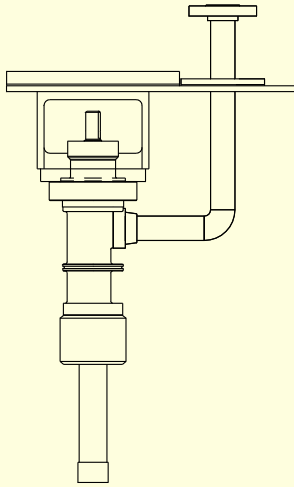

TANK TOP MOUNTED AXIAL SUCTION (KCA)

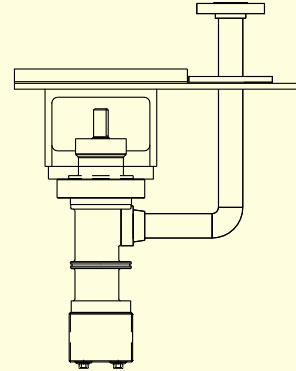

TANK TOP MOUNTED RADIAL SUCTION (KCA)

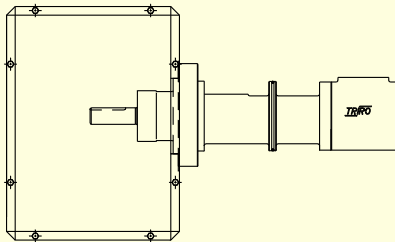

PEDESTAL MOUNTED CARTRIDGE (TCA)

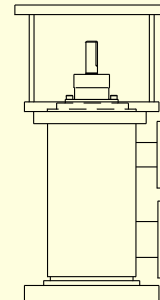

VERTICAL MOUNTED PUMP (LCA)

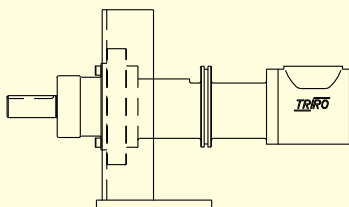

BRACKET MOUNTED (FCA)

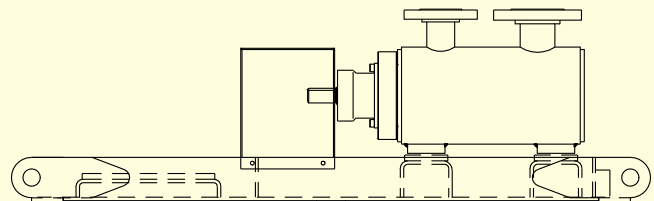

BEDPLATE MOUNTED (HCFA)

PERFORMANCE DATA

Pump Size	Speed		Normal Lead									Short Lead								
			40 cSt			150 cSt			750 cSt			40 cSt			150 cSt			750 cSt		
			6.7 Bar	21 Bar	41 Bar	6.7 Bar	21 Bar	41 Bar	6.7 Bar	21 Bar	41 Bar	6.7 Bar	21 Bar	41 Bar	6.7 Bar	21 Bar	41 Bar	6.7 Bar	21 Bar	41 Bar
38-4	1450	L/Min	60	52	46	65	61	57	68	66	64	47	41	34	52	48	45	54	53	51
		kW	1	2.6	5.0	1.2	2.9	5.4	1.5	3.3	5.9	0.8	2.1	4.1	1.0	2.3	4.3	1.3	2.7	4.8
	2900	L/Min	130	123	117	135	131	127	138	137	135	104	98	91	108	105	102	111	109	108
		kW	2.2	5.5	10	2.67	6.1	11.2	3.7	7.6	12.7	1.7	4.4	8.4	2.2	4.9	9.0	2.9	5.9	10.2
45-4	1450	L/Min	103	92	84	110	104	99	114	115	109	81	72	63	87	83	78	91	89	87
		kW	1.7	4.4	8.3	1.98	4.8	8.9	2.57	5.5	9.9	1.3	3.6	6.8	1.58	3.82	6.8	2.06	4.4	7.9
	2900	L/Min	221	210	202	228	222	217	232	230	227	221	166	157	182	177	172	185	183	181
		kW	3.6	9.2	17	4.5	10.2	18.7	6.2	12.2	21.2	3.6	7.3	14	3.6	8.1	13.8	4.9	9.7	16.9
52-4	1450	L/Min	162	153	137	171	164	156	176	173	170	128	116	104	136	130	124	141	138	135
		kW	2.5	4.7	12.8	3.04	7.4	13.8	3.96	8.5	15.2	2.1	5.5	10.5	2.43	5.9	11	3.16	6.8	12.2
	2900	L/Min	343	335	318	352	345	338	358	355	351	273	261	249	281	275	269	286	283	280
		kW	5.6	9.8	26	6.9	15.6	28.7	9.5	18.7	32.6	4.5	11.3	21.5	5.5	12.5	23	7.6	15	26.1
60-4	1450	L/Min	253	233	218	266	256	246	274	269	265	201	184	168	212	203	195	218	215	211
		kW	3.9	10.5	19.8	4.7	11.4	21.3	6.11	13.1	23.5	3.2	8.4	16.3	3.8	9.1	17	4.9	10.5	18.8
	2900	L/Min	533	513	499	546	536	526	554	549	545	425	408	392	436	428	419	443	439	435
		kW	8.6	21.8	40.5	10.6	24	44.4	14.6	29	50	6.9	17.4	33.3	8.5	19.3	35.5	11.7	23.2	40.4
70-4	1450	L/Min	408	381	361	426	412	398	436	430	424	324	302	279	340	328	316	349	343	338
		kW	6.0	17.0	31.5	7.5	18	33.9	9.71	21	37.3	5	13.4	26	6.0	14.4	27.1	7.77	16.6	29.8
	2900	L/Min	853	826	807	871	857	844	REFER TO PLENTY LIMITED			681	658	635	696	684	672	REFER TO PLENTY LIMITED		
		kW	13.7	35	64.3	16.8	38.3	70.5	REFER TO PLENTY LIMITED			11	27.7	53	13.5	31	56	REFER TO PLENTY LIMITED		
80-4	1450	L/Min	611	576	550	634	616	598	648	640	632	486	456	427	506	491	475	518	511	504
		kW	9.4	25	46.5	11.1	26.7	50.3	14.4	30.7	55.3	7.5	20	38.3	8.8	21.4	38.1	11.5	24.6	44.2
	2900	L/Min	Please Refer to Plenty Limited for speeds in excess of 1450 R.P.M.																	
		kW	Please Refer to Plenty Limited for speeds in excess of 1450 R.P.M.																	

Pumps can also be selected for 60 Hz motor supply.

FULL DATA ON REQUEST

PRESSURE

Maximum Discharge Pressure
Normal Lead 41 Bar
Short Lead 50 Bar

Maximum Suction Pressure
Normal Lead 38 Bar
Short Lead 46 Bar

TEMPERATURE

Standard -20°C to +100°C
High temperature range up to +120°C

ROTATION

Clockwise as standard.
(Anticlockwise available as non-standard)

VISCOSITY

Maximum 3000 cSt

SPEED

Up to 5000 R.P.M.

Pump can be constructed to API 610 / 614 / 676 or individually customised

Operation Three screw pump with one, central, power driven rotor intermeshing with idlers rotors, balanced and machined to effect a seal for the liquid being pumped

Plenty Mirrlees Pumps

Plenty Mirrlees Pumps, Earl Haig Road, Hillington, Glasgow G52 4JN, Scotland, UK.
Telephone: 0141 883 0314 (Int: 44 141 883 0314) Facsimile: 0141 882 2752 (Int: 44 141 882 2752)
Email: pumps.plenty@processequipment.spx.com Website: www.plentymirrleespumps.com