

/ Marley QuadraFlow[®] Cooling Tower /

User Manual 92-1333H



Contents

Note

This manual contains vital information for the proper installation and operation of your cooling tower. Carefully read the manual before installation or operation of the tower and follow all instructions. Save this manual for future reference.

| | Page |
|--|-------------|
| Tower Location | 4 |
| Tower Shipment..... | 5 |
| Receiving Tower | 5 |
| Tower Assembly | 5 |
| Motor Wiring | 5 |
| Tower Start-Up | 10 |
| Tower Maintenance..... | 13 |
| Water Treatment and Blowdown..... | 13 |
| Schedule of Tower Maintenance | 15 |
| Seasonal Shutdown Instructions | 18 |
| Motor Relubrication Instructions | 19 |
| Prolonged Shutdown | 19 |
| Additional Services..... | 20 |
| Additional Information | 21 |
| Troubleshooting..... | 22 |

Warning

Indicates presence of a hazard which can cause severe personal injury, death or substantial property damage if ignored.

Caution

Indicates presence of a hazard which will or can cause personal injury or property damage if ignored.

Note

Indicates special instructions on installation, operation or maintenance which are important but not related to personal injury hazards.

Installation

The Marley QuadraFlow cooling tower purchased for this installation represents the current state of the art in corrosion resistant cooling tower design and construction. The QuadraFlow represents a major step forward in low-maintenance, long-life cooling towers.

These instructions—as well as those offered separately on motors, fans, Geareducers, driveshafts, float valves, etc.—are intended to assure that the tower serves you properly for the maximum possible time. Since the QuadraFlow's warrantability may well depend upon your actions, please read these instructions thoroughly prior to operation.

If you have questions about the operation and/or maintenance of this tower, and you don't find the answers in this manual, please contact your Marley sales engineer. When writing for information, or when ordering parts, please mention tower serial number shown on the tower's nameplate.

Tower Location

Space available around the tower should be as generous as possible to promote ease of maintenance—and to permit freedom of airflow into and through the tower. If you have questions about the adequacy of the available space and the intended configuration of the tower, please contact your Marley sales engineer for guidance.

Prepare a stable, level support foundation for the tower, utilizing weight, wind load, and dimensional information appearing on appropriate Marley submittal drawings. Supports must be level to insure proper operation of the tower.

⚠ Warning

The cooling tower must be located at such distance and direction to avoid the possibility of contaminated tower discharge air being drawn into building fresh air intake ducts. The purchaser should obtain the services of a Licensed Professional Engineer or Registered Architect to certify that the location of the tower is in compliance with applicable air pollution, fire, and clean air codes.

Tower Shipment

QuadraFlow towers ship by truck (on flat bed trailers) in an unassembled condition. Single cell towers ship on one truck. Multicell towers, depending on their size, may require more than one truck. Responsibility for the condition of the tower upon its arrival belongs to the trucker—as does the coordination of multiple shipments, if required.

Installation

Receiving Tower

Prior to unloading the tower from the delivering carrier, inspect the shipment for evidence of damage in shipment. If damage is apparent, note the freight bill accordingly. This will support your future recovery claim.

Tower Assembly

Your Marley sales representative is able to provide for the tower assembly by SPX's construction division or through a qualified subcontractor. Our subcontractors provide safe, efficient assembly which complies with all requirements for five-year warranty protection of your tower by SPX.

Motor Wiring

Wire motor leads as shown on the motor nameplate matching the supply voltage. Do not deviate from the motor nameplate wiring.

Either of following symbols may be shown on the motor nameplate – Δ , $\Delta \Delta$, Y, or YY. These symbols represent how the motor is constructed on the inside and in no way have anything to do with a Delta or Wye electrical distribution system serving the motor.

When using a starter:

- Set motor overload protection to 110% of motor nameplate amps. This setting allows the fan motor to operate during cooler weather. During cooler weather it is common for the motor to draw 6 to 10% higher than the nameplate amps. High amps are common during tower commissioning when the tower is dry and the ambient air temperature is cool.

Note

Do not start the motor more than four to five times per hour. Short cycling the tower will cause fuses, breakers or O.L.s to operate and will decrease motor life.

When using a two-speed starter:

- Motor rotation must be the same at slow speed and high speed.
- Single winding motor requires a starter with a shorting contactor.
- Two-winding motor requires a starter with out a shorting contactor.
- All two-speed starters must have a 20 second time delay relay when switching from high speed to low speed.



Installation

Note

Do not start the motor more than four to five times per hour (each low speed start and each high speed start count as one start).

When using a VFD:

Note

Before beginning, ensure that the motor is rated for “Inverter Duty” per NEMA MG-1, part 31.

- Set the VFD solid state overload protection to 119% of motor nameplate amps and set “maximum current parameter” in the VFD to motor nameplate amps. “Maximum current parameter” will reduce fan speed and limit amp draw to nameplate amps during cold weather operation. If furnished with a mechanical O.L. set this at 110% over motor nameplate amps.
- Motor rotation must be the same in both VFD mode and By-pass mode.
- If cable distance between the VFD and motor is greater than 100 feet a DV/DT output filter is recommended to avoid damage to the motor. 100 feet distance is based on our field experience, the VFD manufacture may state different distances and distance does vary depending on the VFD manufacture.
- Program the VFD for variable torque output. Flux vector and constant torque modes may damage the gearbox.
- Do not start and stop the motor using the safety switch at the motor. If the drive is being commanded to run and the load side is cycled ON and OFF with the safety switch this may damage the VFD.

Using a VFD in cooling applications has advantages over traditional single or two speed motor control. A VFD can reduce the cost of electrical energy being used and provide better temperature control. In addition, it reduces the mechanical and electrical stress on the motor and mechanical equipment. Electrical savings can be large during periods of low ambient temperature when the cooling requirement can be satisfied at reduced speeds. To benefit from these advantages, it is important that the drive be installed correctly.

Marley supplies VFD and VFD controls specifically designed for our cooling products. If you have purchased a Marley VFD and/or controls package, please follow the instructions in the *User Manual* for that system. Most VFD

Installation

problems can be avoided by purchasing the Marley drive system. If you are installing a VFD other than the Marley drive, please refer to that drives installation manual.

⚠ Warning

Improper use of a VFD may cause damage to equipment or personal injury. Failure to correctly install the VFD drive will automatically void all warranties associated with the motor and any equipment that is either electrically or mechanically (directly) attached to the VFD drive system. The length of this warranty avoidance will be contingent on properly installing the VFD system and repairing any damage that may have occurred during its operation. SPX Cooling Technologies does not assume responsibility for any technical support or damages for problems associate with non-Marley brand VFD systems.

⚠ Warning

Changing the operational fan speed from the factory settings could cause the fan to operate in an unstable region which may result in damage to the equipment and possible injury.

Mechanical Equipment

⚠ Warning

Always make certain that mechanical equipment is inoperable during periods of maintenance—or during any situation of possible endangerment to personnel. If your electrical system contains a disconnect switch, lock it out until the period of exposure to injury is over.

1. Check the Geareducer oil level at the sight glass near the motor. If oil is required, fill to the proper level.
2. Spin the fan manually to assure that all fan blades properly clear the inside of the fan cylinder. Observe the action of the driveshaft couplings to be sure that the motor and Geareducer are properly aligned. If necessary, correct the alignment in accordance with the included driveshaft manual.
3. Momentarily energize (“bump”) the motor and observe rotation of the fan. The fan should rotate in a counterclockwise direction when viewed from below. If rotation is backwards, shut off the fan and reverse two of the three primary leads supplying power to the motor.



Installation

⚠ Caution

If tower is equipped with a two-speed motor, check for proper rotation at both speeds. Check also to see that starter is equipped with a 20-second time delay which prevents direct switching from high speed to low speed. This delay will allow the fan to slow down and will prevent abnormal stress from being applied to the mechanical equipment and the electrical circuit components.

4. Run the motor and observe the operation of the mechanical equipment. Operation should be stable, and there should be no evidence of oil leakage.

Note

If the water supply system is not being operated—or if there is no heat load on the system—motor amps read at this time may indicate an apparent overload of as much as 10–20%. This is because of the increased density of unheated air flowing through the fan. Determination of an accurate motor load should await the application of the design heat load.

General

The cold water temperature obtained from an operating cooling tower will vary with the following influences:

1. **Heat Load:** With the fan in full operation, if the heat load increases, the cold water temperature will rise. If the heat load reduces, the cold water temperature will reduce.

$$\text{Range (°F)} = \frac{\text{Heat Load (Btu/hr)}}{\text{GPM} \times 500}$$

Note that the number of degrees (“range”) through which the tower cools the water is established by the system heat load and the amount of water being circulated, in accordance with the following formula:

The cooling tower establishes only the cold water temperature attainable under any operating circumstance.

2. **Air Wet-Bulb Temperature:** Cold water temperature will also vary with the wet-bulb temperature of the air entering the louvered faces of the tower. Reduced wet-bulb temperatures will result in colder water temperatures. However, the cold water temperature will not vary to the same extent as the wet-bulb. For example, a 20°F reduction in wet-bulb may result in only a 15°F reduction in cold water temperature.

Installation

3. **Water Flow Rate:** Increasing the water flow rate (GPM) will cause a slight elevation in cold water temperature, while reducing the water flow rate will cause the cold water temperature to lower slightly. However, at a given heat load (see formula above), GPM reductions also cause an increase in the incoming hot water temperature. Use care to prevent the hot water from exceeding 125°F, in order to prevent damage to the tower components.
4. **Airflow Rate:** Reducing airflow through the tower causes the cold water temperature to rise. This is the approved method by which to control leaving water temperature.

If your tower is equipped with a single-speed motor, the motor may be shut off when the water temperature becomes too cold. This will cause the water temperature to rise. When the water temperature then becomes too warm for your process, the motor can be restarted.

Fan cycling limits:

Note

Considering the normal fan and motor sizes utilized on MCW towers, anticipate that approximately 4 to 5 starts per hour are allowable.

If your tower is equipped with a two-speed motor, greater opportunity for temperature control is afforded you. When the water temperature becomes too cold, switching the fan to half-speed will cause the cold water temperature to rise—stabilizing at a temperature a few degrees higher than before. With a further reduction in water temperature, the fan may be cycled alternately from half-speed to off.

Note

Do not start the motor more than four to five times per hour (each low speed start and each high speed start count as one start).

If your tower consists of two or more cells, cycling of motors may be shared between cells, increasing your steps of operation accordingly. For greater insight on cold water temperature control, please read *Marley Technical Report #H-001-A*, "Cooling Tower Energy and its Management" available for download at spxcooling.com.

Operation

Tower Start-Up

Warning

*Among other sources, outbreaks of Legionnaires' Disease have reportedly been traced to cooling towers. Maintenance and water treatment procedures that prevent amplification and dissemination of Legionella and other airborne bacteria should be formulated and implemented **BEFORE** systems are operated and continued regularly thereafter to avoid the risk of sickness or death.*

Water System

1. New installations should be cleaned and treated with biocides by a water treatment expert before startup.
2. Remove any and all accumulated debris from tower. Pay particular attention to inside areas of cold water basin, entire hot water basin, and hot water inlet. Make sure that cold water suction screens are clear and installed in place.
3. Fill the water system to an approximate depth of 3" in the elevated section of the cold water basin. This is the recommended operating water level. Adjust the float valve so that it is essentially closed at that level. Continue filling the system until the water reaches a level approximately $\frac{1}{8}$ " **below the lip of the overflow.**
4. Start your pump(s). Observe system operation. Since the water system external to the tower will have been filled only to the level achieved in the cold water basin, a certain amount of "pump-down" of the basin water level will occur before water completes the circuit and begins to fall from the fill. The amount of initial pump-down may be insufficient to cause the float valve to open. However, you can check its operation by pressing down on the operating lever to which the stem of the float valve is attached.
5. Continue pump operation for about 15 minutes, after which it is recommended that the water system be drained, flushed, and refilled in order to clean the system.
6. While operating the condensing water pump(s) and prior to operating the cooling tower fan, execute one of the two alternative biocidal treatment programs described in the following:
 - Resume treatment with the biocide which had been used prior to shut-down. Utilize the services of the water treatment supplier. Maintain the maximum recommended biocide residual (for the specific biocide) for

Operation

a sufficient period of time (residual and time will vary with the biocide) to bring the system under good biological control

or

- Treat the system with sodium hypochlorite to a level of 4 to 5 mg/L (ppm) free chlorine residual at a pH of 7.0 to 7.6. The chlorine residual must be held at 4 to 5 mg/L (ppm) for six hours, measurable with standard commercial water test kits.

If the cooling tower has been in operation and then shut down for a duration of time and not drained, perform one of the two previous biocidal treatment programs directly to the cooling water storage vessel (cooling tower sump, drain down tank, etc.) without circulating stagnant water over the cooling tower fill or operating the cooling tower fan.

After biocidal pretreatment has been successfully completed, cooling water may be circulated over the tower fill with the fan off.

When biocidal treatment has been maintained at a satisfactory level for at least six hours, the fan may be turned on and the system returned to service. Resume the standard water treatment program, including biocidal treatment.

Wintertime Operation

During operation in subfreezing weather, the opportunity exists for ice to form in the colder regions of the tower. Your primary concern is to prevent the formation of destructive ice on the cooling tower fill. Your understanding of cold weather operation will be enhanced if you read *Marley Technical Report #H-003*, "Operating Cooling Towers in Freezing Weather," available for download at spxcooling.com, augmented by the following guidelines:

1. ***Do not allow the tower's leaving water temperature to drop below a minimum allowable level—about 40°F—established as follows:***

During the coldest days of the first winter of operation, observe whether any ice is forming on the louver face, particularly near the bottom of the louver face. If hard ice is present on the louvers, an appropriate elevation in the allowable cold water temperature is mandatory. If the coldest possible water is beneficial to your process, ice of a mushy consistency can be tolerated—but routine periodic observation is advisable.

If the minimum allowable cold water temperature is established at or near minimum heat load, it should be safe for all operating conditions.



Operation

Having established the minimum allowable cold water temperature, maintaining that temperature can be accomplished by fan manipulation, as outlined in **Item 4** under **Tower Operation** on page 8. *However, in towers of more than one cell, the limiting temperature established applies to the water temperature of the cell or cells operating at the highest fan speed—not necessarily the net cold water temperature produced by the entire tower.*

2. As cold air enters the louvers, it causes the falling water to be drawn inward toward the center of the tower. Thus, under fan operation, the louvers and lower periphery of the tower structure remain partly dry, seeing only random splashing from within the tower—plus normal atmospheric moisture from the entering air. Such lightly wetted areas are most subject to freezing.

Although ice is unlikely to cause structural damage to the fill, it may build up sufficiently to restrict the free flow of air through the louvers. This will have the effect of reducing the tower's thermal performance efficiency. When excessive ice forms on the louvers, stop the fan for a few minutes. With the fan off, the increase in the water temperature and the action of the cascading water will reduce the ice buildup on the louvers.

Intermittent Wintertime Operation

If periods of shutdown (nights, weekends, etc.) occur during freezing weather, measures must be taken to prevent the water in the cold water basin –and all exposed pipework—from freezing. Several methods are used to combat this, including automatic basin heater systems available from Marley. It is recommended that you discuss your freeze prevention options with your local Marley sales representative.

Caution

Unless some means of freeze prevention is incorporated into your system, the tower basin and exposed pipework should be drained at the beginning of each wintertime shutdown period.

Warning

If tower basin is drained, verify that all basin heaters have been shut off either by automatic cutoff or disconnect switch.

Maintenance

Water Treatment and Blowdown

Maintaining Water Quality:

The materials used in the QuadraFlow tower are selected to offer long, corrosion-free service in a “normal” cooling tower environment, defined as follows:

- Circulating water with a pH between 6 and 8; a chloride content (as NaCl) below 750 ppm; a sulfate content (SO₄) below 1200 ppm; a maximum inlet water temperature not to exceed 125°F; no significant contamination with unusual chemicals or foreign substances; and adequate water treatment to minimize scaling.
- Chlorine (if used) shall be added intermittently, with a free residual not to exceed 1 ppm – maintained for short periods. Excessive chlorine levels may deteriorate sealants and other materials of construction.
- An atmosphere surrounding the tower no worse than “moderate industrial,” where rainfall and fog are no more than slightly acid, and they do not contain significant chlorides or hydrogen sulfide (H₂S).

Cooling Tower Cleaning

⚠ Warning

Any evaporative-type cooling tower must be thoroughly cleaned on a regular basis to minimize the growth of bacteria, including Legionella Pneumophila, to avoid the risk of sickness or death. Service personnel must wear proper personal protective equipment during decontamination. Do NOT attempt any service unless the fan motor is locked out.

Operators of evaporative cooling equipment, such as water cooling towers, should follow maintenance programs which will reduce to an absolute minimum the opportunity for bacteriological contamination. US Public Health Service publications have recommended that “good housekeeping” procedures be followed, such as: regular inspections for concentrations of dirt, scale, and algae; periodic flushing and cleaning; and the following of a complete water treatment program including biocidal treatment. See Tower start-up instructions on page 10.

Maintenance

The visual inspection should take place at least once a week during the operating season. The periodic flushing and cleaning should be done before and after each cooling season, but in any event at least twice a year. The louvers, drift eliminators, and easily accessible fill surfaces should be flushed by use of a moderate-pressure water nozzle, being careful not to cause physical damage. A reliable water treatment program should be installed and maintained. Filtration devices may be employed to reduce the suspended solids concentrations, thus increasing the effectiveness of the water treatment program.

Blowdown

A cooling tower cools water by continuously causing a portion of it to evaporate. Although the water lost by evaporation is replenished by the makeup system, it exits the tower as pure water—leaving behind its burden of dissolved solids to concentrate in the remaining water. Given no means of control, this increasing concentration of contaminants can reach a very high level.

In order to achieve water quality which is acceptable to the cooling tower (as well as the remainder of your circulating water system), the selected water treatment company must work from a relatively constant level of concentrations. This stabilization of contaminant concentrations is usually accomplished by blowdown, which is the constant discharge of a portion of the circulating water to waste. As a rule, acceptable levels on which to base a treatment schedule will be in the range of 2-4 concentrations. The following table gives approximate rates of blowdown (percent of total water flow rate constantly wasted) to achieve those concentrations at various cooling ranges.*

| Cooling Range (°F) | Blowdown Rate | |
|-----------------------|-----------------------|------------------------|
| | Two Concentrations | Four Concentrations |
| 10 | 0.7% | 0.17% |
| 15 | 1.1% | 0.30% |
| 20 | 1.5% | 0.43% |

*Range = Difference between hot water temperature entering the tower and cold water temperature leaving the tower.

Note

When water treatment chemicals are added, they should not be introduced into the circulating water system via the cold water basin of the cooling tower. Water velocities are lowest at that point, which results in inadequate mixing.

Maintenance

Schedule of Tower Maintenance

Included with this instruction packet are separate Service Manuals on each major operating component of the tower, and it is recommended that you read them thoroughly. Where discrepancies may exist, the separate Service Manuals will take precedence.

⚠ Warning

Do not use the top horizontal surface of the tower as a working platform. The tower is designed so that all maintenance can be performed from the exterior and interior of the tower. Do not use the upper basin covers as a walking surface or working platform. Remove basin covers and use portable ladders whenever performing service on the hot water basin. Use of ladder should be in accord with manufacturer's recommendations

The following is recommended as a minimum routine of scheduled maintenance:

⚠ Warning

Always shut off electrical power to the tower fan motor prior to performing any inspections that may involve physical contact with the mechanical or electrical equipment in or on the tower. Lock out and tag out any electrical switches to prevent others from turning the power back on. Service personnel must wear proper personal protective clothing and equipment.

Weekly: Inspect for bacterial growth and general operation conditions. Bacterial growth should be reported to your water treatment expert for immediate attention.

Monthly (Weekly at Start-up): Observe, touch, and listen to the tower. Become accustomed to its normal appearance, sound, and level of vibration. Abnormal aspects relating to the rotating equipment should be considered reason to shut down the tower until the problem can be located and corrected. Observe operation of the motor, driveshaft, Geareducer and fan. Become familiar with the normal operating temperature of the motor, as well as the sight and sound of all components as a whole.

Check Geareducer oil level. Shut down the unit and allow 5 minutes for the oil level to stabilize. Add oil if required. Check system for leaks if the amount of oil required appears unusual. (If oil is added at the external fill port, allow adequate time for the level to stabilize before reading final level.)

Maintenance

Inspect louvers, drift eliminators and basin trash screens and remove any debris or scale which may have accumulated. Replace any damaged or worn out components. Use of high-pressure water may damage the eliminator and louver material.

Observe operation of the float valve. Depress the operating lever to make sure that the valve is operating freely. Inspect the suction screen for plugging. Remove any debris that may have accumulated.

Check for any buildup of silt on the floor of the cold water basin. Mentally note the amount, if any, so future inspections will enable you to determine the rate at which it is forming.

Semi-Annually: Relubricate motor according to the manufacturer's instructions. See instructions on page 19.

Check to see that all bolts are tight in the fan and mechanical equipment region, including the fan guard. Use torque settings prescribed on the fan nameplate.

Clean and disinfect cooling tower with biocides. Systems with biofouling, high general bacterial counts, or positive cultures of legionella may require additional cleaning. Refer to "Cooling Tower Cleaning" section on page 13. Consult your water treatment expert as to prudent biological evaluation testing..

Note

To maintain five-year change intervals, use only oil designed specifically for these Geareducers. If, after five years, turbine-type mineral oil is used, the oil must be changed semiannually. Refer to *Geareducer User Manual* for oil recommendations and further instructions.

Annually: Inspect the tower thoroughly, making maximum use of instructions given in the separate service manuals. Check structural bolted connections and tighten as required. Make preventive maintenance repairs as necessary.

Every 5 Years: Change Geareducer oil. Refer to *Geareducer User Manual* for instructions.

Maintenance Schedule

| Maintenance Service | Monthly | Semi-annually | Seasonal Startup or Annually |
|---|-----------------|-----------------|------------------------------|
| Inspect General Condition and Operation | x | | x |
| Observe Operation of: | | | |
| Mechanical—motor, fan and drive mechanism | x | | x |
| Makeup valve (if equipped) | x | | x |
| Inspect for unusual noise or vibration | x | | x |
| Inspect and Clean: | | | |
| Air inlet | x | | x |
| PVC drift eliminators | x | | x |
| Distribution basin, nozzles and collection basin | x | | x |
| Fan motor exterior | x | | x |
| Check: | | | |
| Collection water basin level | x | | x |
| Blowdown—adjust as required | x | | x |
| Geareducer Drive | | | |
| Check for loose fasteners including oil drain plug | | | x |
| Check for / repair oil leaks | x | | x |
| Check oil level | x | | x |
| Change oil | | R | |
| Make sure vent is open | | | x |
| Check driveshaft alignment | | | x |
| Check for loose driveshaft or coupling fasteners | | | x |
| Check driveshaft flex element for unusual wear | | x | x |
| Lube lines: | | | |
| Check for oil leaks in hoses or fittings | x | | x |
| Fan: | | | |
| Check and tighten blade and hub fasteners | | | x |
| Check fan blade pitch and tip clearance | | | x |
| Check fan cylinder for loose fasteners | | | x |
| Motor: | | | |
| Lubricate (grease as required) | | | R |
| Check mounting bolts for tightness | | | x |
| Operate at least | 3 hours a month | 3 hours a month | 3 hours a month |
| Basin Heater (if equipped): | | | |
| Check for proper operation of temp/low water level sensor | | | x |
| Inspect/clean buildup of contaminant from sensor | | x | x |
| Structure: | | | |
| Inspect/tighten all fasteners | | x | x |
| Inspect and touch up all metal surfaces | | | x |

R — Refer to Component User Manual

Note: It is recommended at least weekly, that the general operation and condition be observed. Pay attention to any changes in sound or vibration that may signify a need for closer inspection.

Maintenance

Seasonal Shutdown Instructions

When the system is to be shut down for an extended period of time, it is recommended that the entire system (cooling tower, system piping, heat exchangers, etc.) be drained. Leave the basin drain open.

During shutdown, clean the tower and make any necessary repairs. Pay particular attention to mechanical equipment supports and driveshafts.

Tower Framework: Check structural bolted connections and tighten as required.

Driveshaft: Check driveshaft alignment, tightness of cap screws and set screws, and condition of all components. Refer to driveshaft service manual.

Fan: Check fan assembly bolting and tighten as required. Use torque settings prescribed on the fan nameplate. Refer to fan service manual.

Electric Motor: Clean and lubricate motor at close of each operating season. (Refer to motor manufacturer's recommendations.) Check motor anchor bolts and tighten as required. See Page 19 for motor lubrication instructions.

⚠ Warning

Do not start motor before determining that there will be no interference with free rotation of the fan drive.

The motor should be operated for three hours at least once a month. This serves to dry out windings and re-lubricate bearing surfaces. Refer to "Marley Electric Motor User Manual" *Manual 92-1475*.

At start of new operating season, make sure bearings are adequately lubricated before returning motor to service.

Maintenance

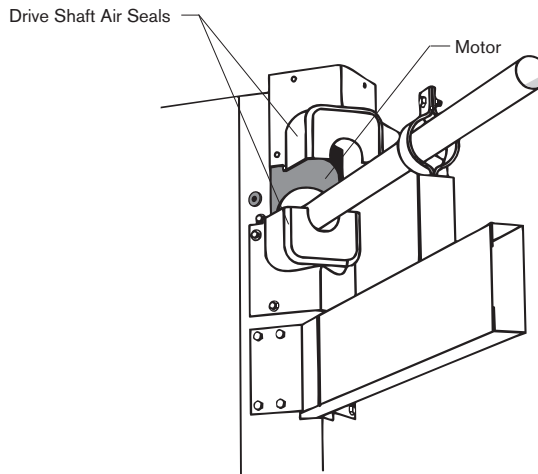

Motor Lubrication Instructions

⚠ Warning

Open and lock out disconnect switch to make certain motor cannot be started.

1. Remove interior driveshaft air seals as shown above. Opposite end motor bearing is accessible by removing motor cover (24000 models do not have a motor cover) on the exterior of the tower.
2. Relubricate motor according to the manufacturer's instructions.

Fiberglass Components: Check all fiberglass parts for exposed glass fibers. If found, the affected surfaces should be roughened up and solvent wiped. Surfaces must be clean and dry and free of oil, grease or other contaminants before applying new coating. The best coating system requires using a two-part polyamide epoxy primer to promote adhesion and a two-part acrylic polyurethane enamel for the topcoat. Contact your Marley sales representative if additional information is required.

Prolonged Shutdown

If shutdown period is longer than seasonal, contact your Marley sales engineer for additional information.

Maintenance

Additional Services

SPX's interest in your Marley QuadraFlow cooling tower does not end with the sale. Having conceived, designed, and manufactured the most reliable and longest lasting cooling tower of its class, we want to make sure that you gain the maximum possible benefit from its purchase.

Therefore, the following services are available which are intended to assure the maximum possible service life under your operating conditions, tailor the operating characteristics to your specific needs, and maintain consistent optimum thermal performance capability. They are available by contacting your Marley sales representative.

Replacement Parts

With the exception of the motor, every component of your tower is designed and manufactured by SPX Cooling Technologies. We do this because commercially available components have not proved capable of withstanding the harsh environment of a cooling tower—nor do they contribute their share to the thermal capability and operating characteristics intended.

A complete stock of all parts and components is maintained at one or more of the various Marley plants. In cases of emergency, they can normally be shipped within 24 hours—by air freight, if necessary. However, you would obviously benefit from anticipating your need in advance, thus avoiding the cost of special handling.

Be sure to mention your tower serial number (from the tower nameplate) when ordering parts. Refer to assembly manual for part identification.

Periodic Maintenance

You may wish to contract with Marley for regularly scheduled visits—for the purpose of inspecting and reporting your tower's condition—to make recommendations intended to prevent emergencies—and to perform maintenance considered outside the norm.

This service is not intended to replace the important function performed by your maintenance staff. Their attention assures the tower's routine operating performance, and is invaluable. However, Marley recognizes that the unusual manner in which a cooling tower performs its function—as well as the unique forces which act upon it—may be considerations which occasionally require the services of an expert technician.

Additional Information

Increased Load Requirements: QuadraFlow towers are designed such that cells of either equal or unequal capacity can be added in the future. This allows you to compensate for the load increases that normally occur with the replacement or addition of production equipment—and still retain continuity with respect to your cooling tower system.

Tower Renewal: Marley routinely rebuilds and upgrades cooling towers of all materials and manufacture. If your tower ever reaches the limit of its service life, we recommend that you investigate the cost of rebuilding before you routinely order a new replacement tower.

Each QuadraFlow tower includes a document package containing general orientation drawings and manuals to accomplish field assembly and installation. ***These drawings and manuals contain important information relating to safe installation and operation of the cooling tower.*** A separate installation drawing for each purchased option is included in the document package. If you have purchased an option and can't find the appropriate installation drawing, contact your local Marley sales representative before proceeding.

SPX also provides several sets of a separate packet of pertinent operating and maintenance manuals. The manuals vary somewhat depending on the tower model purchased.

In addition, SPX publishes numerous technical reports including more detailed information on a variety of cooling tower operation and service topics available to download at spxcooling.com. For complete parts and service assistance, contact the Marley sales or representative office in your area. If you need help locating the office nearest you, please phone 913 664 7400 or check the web at spxcooling.com.

Troubleshooting

| Trouble | Cause | Remedy |
|--|---|--|
| Motor will not start | Power not available at motor terminals | <ol style="list-style-type: none"> 1. Check power at starter. Correct any bad connections between the control apparatus and the motor. 2. Check starter contacts and control circuit. Reset overloads, close contacts, reset tripped switches or replace failed control switches. 3. If power is not on all leads at starter, make sure overload and short circuit devices are in proper condition. |
| | Wrong connections | Check motor and control connections against wiring diagrams. |
| | Low voltage | Check nameplate voltage against power supply. Check voltage at motor terminals. |
| | Open circuit in motor winding | Check stator windings for open circuits. |
| | Motor or fan drive stuck | Disconnect motor from load and check motor and Geareducer for cause of problem. |
| | Rotor defective | Look for broken bars and rings. |
| Unusual motor noise | Motor running single-phase | Stop motor and attempt to start it. Motor will not start if single-phased. Check wiring, controls and motor. |
| | Motor leads connected incorrectly | Check motor connections against wiring diagram on motor. |
| | Bad bearings | Check lubrication. Replace bad bearings. |
| | Electrical unbalance | Check voltage and currents of all three lines. Correct if required. |
| | Air gap not uniform | Check and correct bracket fits or bearing. |
| | Rotor unbalance | Rebalance. |
| | Cooling fan hitting end bell guard | Reinstall or replace motor fan. |
| Fan noise | Blade rubbing inside of fan cylinder | Adjust cylinder to provide blade tip clearance. |
| | Loose bolts in blade clamps | Check and tighten if necessary. Check fan blade pitch. Refer to Fan Service Manual. |
| Scale or foreign substance in water system | Lack of or insufficient bleed-off | See "Water Treatment" section of this manual. |
| | Water treatment | Consult competent water treating specialist. See "Water Treatment" section of this manual. |
| Motor does not come up to speed | Voltage too low at motor terminals because of line drop | Check transformer and setting of taps. Use higher voltage on transformer terminals or reduce loads. Increase wire size or reduce inertia. |
| | Broken rotor bars | Look for cracks near the rings. A new rotor may be required. Have motor service center check motor. |
| Wrong rotation (Motor) | Wrong sequence of phases | Switch any two of the three motor leads. |
| Excessive water drift | Faulty drift elimination | <ol style="list-style-type: none"> 1. See if all louvers and eliminators are in place and clean. 2. Check to see that nozzles are in place and clean of debris. |
| | Overpumping | Reduce water flow rate to tower to design conditions. |
| Cold water too warm (See "Tower Operation") | Overpumping | Reduce water flow rate to tower to design conditions. |
| | Not enough air | Check motor current and voltage to be sure of correct contract horsepower. Clean louvers, fill and eliminators. |

Troubleshooting

| Trouble | Cause | Remedy |
|-----------------------------|---|--|
| Unusual fan drive vibration | Loose bolts and cap screws | Tighten all bolts and cap screws on all mechanical equipment and supports. |
| | Unbalanced driveshaft or worn couplings | Make sure motor and Geareducer shafts are in proper alignment and "match marks" properly matched. Repair or replace worn couplings. Rebalance driveshaft by adding or removing weights from balancing cap screws. See Driveshaft Service Manual. |
| | Unbalanced fan | Be sure blades are properly positioned in correct sockets. (See match numbers.) Make certain all blades are as far from center of hub as safety devices permit. All blades must be pitched the same. See Fan User Manual. Clean off deposit buildup on blades. |
| | Worn Geareducer bearings | Check fan and pinion shaft endplay. Replace bearings as necessary. |
| | Unbalanced motor | Disconnect load and operate motor. If motor still vibrates, rebalance rotor. |
| | Bent Geareducer shaft | Check fan and pinion shafts with dial indicator. Replace if necessary. |
| Motor runs hot | Motor overload, wrong voltage or unbalanced voltage | Check voltage and current of all three lines against nameplate values. |
| | Wrong motor RPM | Check nameplate against power supply. Check RPM of motor and gear ratio. |
| | Bearings overgreased | Remove grease reliefs. Run motor up to speed to purge excessive grease. |
| | Wrong lubricant in bearings | Change to proper lubricant. See motor manufacturer's instructions. |
| | One phase open | Stop motor and attempt to start it. Motor will not start if single-phased. Check wiring, controls and motor. |
| | Poor ventilation | Clean motor and check ventilation openings. Allow ample ventilation around motor. |
| | Winding fault | Check with Ohmmeter. |
| | Bent motor shaft | Straighten or replace shaft. |
| | Insufficient grease | Remove plugs and regrease bearings. |
| | Too frequent starting | Limit cumulative starting time to a total of 30 seconds each hour. |
| | Deterioration of or foreign material in grease | Flush bearings and re-lubricate. |
| | Bearings damaged | Replace bearings. |
| | Incorrect fan blade pitch | Measure actual fan pitch and compare to that recommended. Correct, if necessary. See Fan User Manual. |
| Geareducer noise | Geareducer bearings | If new, see if noise disappears after one week of operation. Refer to Geareducer User Manual. |
| | Gears | Correct tooth engagement. Replace badly worn gears. Replace gears with imperfect tooth spacing or form. |