

/ Marley MD5016 Cooling Tower /

Field Installation Manual 08-1612



Getting Started	<u>(section-page)</u>
About This Manual.....	1-1
Safety.....	1-1
Part Identification.....	1-1
Tools & Supplies.....	1-2
Measurement System.....	1-2
PVC Fill Storage.....	1-2
A Few Words About Fasteners.....	1-2
General Decal Instructions.....	1-2
Joint Sealing Instructions.....	1-3
Standard Field Details	
Module Connection.....	2-1
Drain Plug.....	2-8
Collection Basin Options	
Sump Outlet	3-1
Bottom Outlet / Equalizer / Inlet Bypass Piping.....	3-3
Bottom Outlet Screen.....	3-4
Outlet Anti-Vortex Plate with Screen.....	3-5
Bottom Inlet Bypass Hood.....	3-6
Flume.....	3-7
Flume Weir Gate.....	3-8
Solenoid Valve.....	3-9
Belt Drive - Field Installed Motor	
Install Motor.....	4-1
Motor Sheave.....	4-3
Belt Installation.....	4-5

Note: Optional equipment not listed in the Table of Contents is installed using separate installation drawings and bills of material. These documents are located within the literature package and should be reviewed prior to starting assembly. Optional equipment may affect assembly sequence.

CONFIDENTIAL - The contents of this document are confidential and constitute the exclusive property of SPX Cooling Technologies Inc.. It is intended for use in the installation (contractor) and maintenance (owner) of this cooling tower. This document and its contents may not be made public in any manner, distributed, loaned to others, reproduced, or copied either in whole or part without prior written consent of SPX Cooling Technologies, Inc.

*© 2008 SPX Cooling Technologies Inc.
Unpublished-All Rights reserved under copyright laws.*

ABOUT THIS MANUAL

To obtain maximum efficiency, it is strongly recommended that this entire manual be read before starting installation. This manual illustrates a typical field installation sequence of a basic tower. Some common options are also included. Refer to separate installation drawings for additional optional equipment. Review all manuals, drawings and bills of material prior to assembly. These documents are located in a Literature Kit packed with the tower. Contact your SPX Cooling Technologies sales representative should questions arise.

SAFETY

The location and orientation of the cooling tower can affect the safety of those responsible for installing, servicing, or repairing the tower. Since SPX Cooling Technologies does not dictate the location, or orientation of the tower, SPX Cooling Technologies is not responsible for addressing the safety issues that are affected by the tower's location, or orientation. The following safety issues should be considered by those responsible for designing the tower installation. Failure to consider and address these issues may result in substantial personal injury, or death to those involved in installing, servicing, or repairing the cooling tower.

- * Access to and from maintenance access doors
- * Access for cleaning and other service
- * Potential access problems due to obstructions surrounding the tower
- * The possible need for ladders (either portable or permanent) to gain access to the maintenance access doors
- * The possible need for safety cages around ladders.

These are only some of the safety issues that may arise in the design process. SPX Cooling Technologies strongly recommends that you consult a safety engineer to be sure all safety considerations have been addressed.

SPX Cooling Technologies offers optional equipment that may assist you in addressing some of these safety issues. Consult your sales representative for information on these optional items.

Safety is the first priority at the job site. Cooling towers are constructed of material that could cause injury if not handled properly. It is recommended that Kevlar gloves and sleeves and eye protection be worn at all time when working with steel, PVC and fiberglass. Hardhats should be worn when working with overhead objects. Steel parts may be heavy and the surfaces may be slick from oil used during fabrication. Take precautions by placing heavy steel parts near or on the ground to minimize the risk of dropping. Although all steel parts are de-burred, the edges of steel can be very sharp and cut easily. Keep a first aid kit handy should the need arise. Use the above suggestions as well as common sense to create a safe working environment. Take steps to prevent tipping or falling hazards. Protection from thrown or falling objects should be used at all times around a construction site. Keep the worksite and assembly area clean. Check tools periodically and replace tools that could break or malfunction. Follow instruction manuals for all powertools and beware of shock hazards that exist.

NEVER HOLD A PIECE OF STEEL IN PLACE USING ONLY A DRIFT PIN. Drift pins have smooth surfaces and are designed to slide in and out of holes very easily. Drift pins can not hold themselves in place. Parts WILL fall if suspended only by a drift pin.



PARTS

All steel parts are tagged for identification, as shown above.

Find Number: This is a three-digit alpha/numeric number that ties the bill of material (BOM) to the drawings. They are identified in the drawings as the alpha/numeric numbers within the circles. The find numbers on the drawings are used in conjunction with the appropriate BOM to find the correct item numbers needed for installation.

THE SAME FIND NUMBERS MAY BE USED FOR DIFFERENT PARTS ON DIFFERENT TOWER CELLS.

Item Number: This number is used by SPX Cooling Technologies to purchase, manufacture and inventory the components of the modules. Give these item numbers to the project manager if an item is missing or a replacement item is required.

Drawing Number: (Reference Only) This is the number of the drawing used to fabricate the item. This number DOES NOT reference the drawing number where the part is used.

Description: (Reference Only) This number describes the dimensions of the flat pattern of the item. These dimensions MAY NOT correspond to the overall dimensions of the part.

The find number, item number, description and quantity of items are all cross referenced on the bill of material. If a number is missing or hard to read, check the illustrations in this assembly manual first and then the bill of material to see if you can find it. As the tower is prepared for assembly, the quantities of each item should be checked against the bill of material.

NEED HELP!

If anything is missing, damaged, or you need help of any kind, contact your SPX Cooling Technologies Representative as soon as possible. If you need help determining the representative in your area, please call us at 1-800-4MARLEY, or check the internet at www.spxcooling.com

MEASUREMENT SYSTEM

The manual uses both, the English System and Metric System of measurement. All units are in millimeters. Fasteners are denoted in both the English and metric systems. Fasteners are supplied in conformance with the metric system standard unless otherwise noted in the tower bills of material.

TOOLS AND SUPPLIES

Hoist: 3,500 pound capacity for hoisting largest tower module. They cannot be lifted/moved with a forklift from the bottom.

Small and large drift pins: (alignment tools) these are extremely important to help line up all the holes.

Combination wrenches: mainly 13mm up to 30mm. May be substituted for impact wrenches.

Socket wrench set: Tower mainly uses 13mm, 19mm & 30mm sockets. have more than one if possible.

Impact wrenches (electric or pneumatic) with standard and deep sockets: used to tighten all hardware.

Pipe wrenches

Allen wrenches

Torque wrench: 100 ft lb (136 N-m) capacity.

Utility knife, Cutting pliers: used to open boxes and unwrap pallets.

Caulking guns: application of sealer to steel and casing.

Acetone solvent: use with clean cotton rags to wipe down steel before applying sealant.

Protractor level: For setting fan blade pitch

Dial Indicator kit: marley item No. 115311. For drive shaft alignment. Needed for motor outside airstream option only.

Scaffolding, portable stairs, ladders or other means of temporary access and support

Wear protective clothing, gloves, nonslip footwear, hard hat and safety glasses. Fluid Coolers are constructed of steel and could have burrs that can cause cuts. The surface of the steel could be slick. Protection from thrown, or falling objects should be used at all times around a construction site.

A FEW WORDS ABOUT FASTENERS

Stainless Steel Fasteners:

Stainless steel fasteners are prone to galling. This is when you notice a sudden increase in the force needed to turn a nut before parts are clamped. Apply anti-seize compound to the threads of the bolt before installing the nut. If a nut does not easily spin on a bolt, do not try to force it. Chances are it will seize. Some extra hardware is included to replace problem hardware.

Tap Screw Repair:

During installation of tap screws in sheet metal parts, tap screws may strip, not allowing the screw to be fully tightened. if this occurs, place a 3/8" [10mm] nut on the back side of the tap screw and tighten.

Torque requirements:

The idealized standard fastener torque values for galvanized and stainless steel fasteners are shown in the table below. These values may vary in actual practice. Note that the values shown for stainless steel fasteners are based on the fasteners being lubricated with anti-seize compound.

BOLT DIAMETER	FASTENER TORQUE	
	FASTENER TORQUE	
	FOOT-LBS. (NEWTON-METERS)	
	GALVANIZED	* STAINLESS STEEL
8mm	20 (27.1)	20 (27.1)
10mm	20 (27.1)	20 (27.1)
12mm	45 (61)	27 (37)
16mm	90 (122)	44 (60)
20mm	150 (203)	74 (100)

Loctite®

Critical structural and mechanical attachments require extra protection against the nuts vibrating loose during tower operation. This is accomplished on galvanized fasteners by applying Loctite, Find# Z05, thread locking compound to the exposed threads of a bolt after the nut has been installed and tightened. Bolts should be installed with the threaded end up or horizontally. Reference details below. *On stainless steel fasteners the use of anti-seize compound makes the use of loctite ineffective. Therefore in these critical areas with stainless steel fasteners, self-locking nuts have been substituted for the standard nuts and loctite will not be used.*

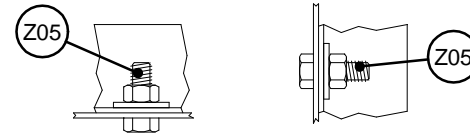

Typical bolted attachment with threaded end of bolt up, or installed horizontally

GENERAL DECAL INSTRUCTIONS

Decals are an important part of the tower assembly. Decals provide instructions, identifications, cautions and warnings deemed necessary for proper operation and safety.

Surface Preparation

Surface must be clean and dry. Oil and dirt may be removed with solvent (such as acetone) or commercial detergent. Wash the area with warm water and dry with a lint-free cloth. Ultimate adhesion will occur 24-28 hours after application should not be undertaken if temperature is below 35 degrees Fahrenheit, or if humidity is greater than 95%.

General Application Instructions

Peel off backing paper, taking care to avoid dirt contamination of the exposed adhesive. Carefully apply decal to the desired location with light pressure to avoid distortion of the vinyl. Once in position, smooth out with a towel. If air bubbles occur, puncture with a pin and smooth down with a towel. The finished decal should be completely flat.

JOINT SEAL INSTRUCTIONS

The following information covering surface preparation applies to all sealed joints whether sealer Z11 or strip sealer Z12 and/or Z13 is being used. The typical joint sealing details shown on this page may be referenced throughout this manual or other optional equipment installation drawings. Years of experience has shown the instructions on surface preparation and sealing details do result in watertight joints. Inadequate attention to the details will result in joints that leak. Do not apply either sealer if temperature is below 40 degrees Fahrenheit (5 degrees Celsius).

All flanges are to be straight. Rework kinks or bends that exist. Clean surfaces being sealed solvent. If cloth is used, it must always be clean and dry. Exercise caution in using solvents, always read labels and instructions. Care should be taken not to wipe dirt or oil onto the cleaned surface from adjacent uncleaned area. Mating surfaces to be sealed must be kept clean and dry prior to assembly. No water, grease or dirt should contaminate cleaned area. Note that stainless steel requires a larger area to be cleaned because oil will contaminate surfaces quickly. Oil will migrate through punched holes and around sheared edges.

Application instructions for Tube Sealer Z11 (Type A, B, & C seals):
 Tube sealer, Find# Z11, cones in a 1/12 gallon (315ml) cartridge and is applied using a standard caulking gun. Apply sealer to unassembled parts. Care should be taken to fill voids and gaps at joints. After parts have been assembled, trowel excess sealant over joint, taking care to force sealant back into joint, not out of joint. Do not use solvent to aid in applying sealer. Solvent adversely affects bonding of sealant to metal. Care should be taken to avoid leaving holes, or bubbles in sealant. Do not subject sealed joints to waterloading for 48 hours at temperatures of 70 degrees Fahrenheit (21 degrees Celsius) and above. Lower temperatures will require a longer cure time.

Application Instructions for Strip Sealer Z12 & Z13 (Type D, E, F & G seals):
 Strip sealer is supplied an 1/2" (13mm) Z13 and 1" (25mm) Z12 widths. It is intended that the 1/2" (13mm) wide sealer be used unless otherwise noted. Apply continuous pieces of strip sealer to the unassembled parts. Do not splice pieces except when turning a corner. Cut with a sharp knife, do not stretch, or tear. Gaps at joints and corners can be filled by spanning a piece of strip sealer to gain the proper thickness. Then work it into the joint to fill gaps and create an even surface. After parts are set together, use a drift pin, or other pointed object, to puncture sealer at each fastener hole where required.

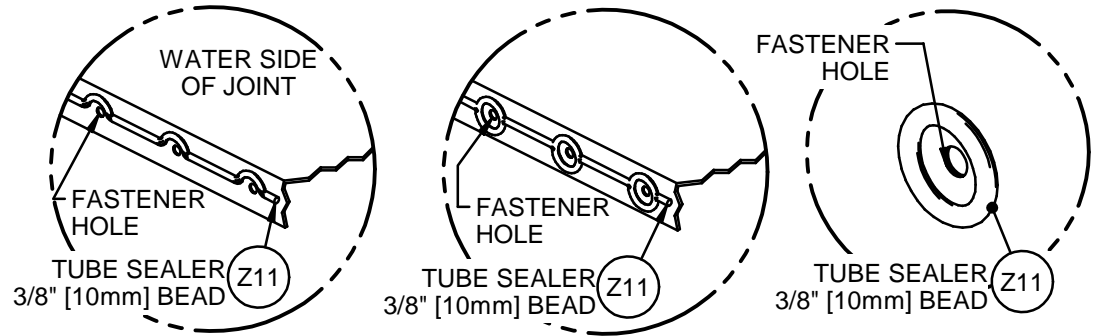

TYPE A

TYPE 'A' (Z11)

This is the symbol used throughout the manual to indicate the locations where a type A seal is required.

TYPE B

TYPE 'B' (Z11)

This is the symbol used throughout the manual to indicate the locations where a type B seal is required.

TYPE C

TYPE 'C' (Z11)

This is the symbol used throughout the manual to indicate the locations where a type C seal is required.

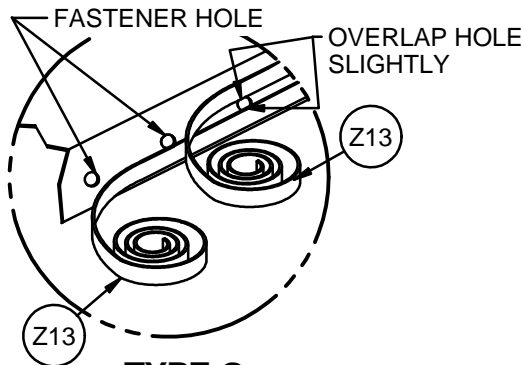

TYPE G

(TYPE 'G') (Z13) (Z13)

This is the symbol used throughout the manual to indicate the locations where a type G seal is required.

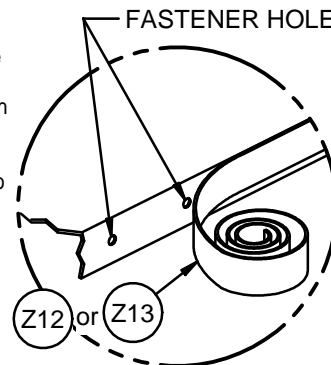

TYPE D

TYPE 'D' (Z13) (Z12) TYPE 'D'

These are the symbols used throughout the manual to indicate the locations where a type D seal is required.

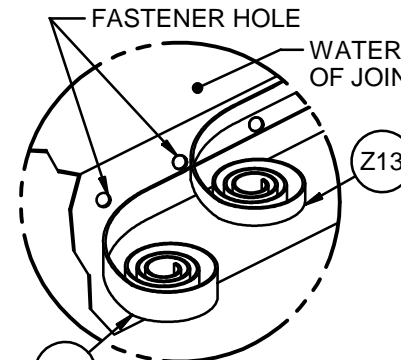

TYPE E

(TYPE 'E') (Z13) (Z12)

This is the symbol used throughout the manual to indicate the locations where a type E seal is required.

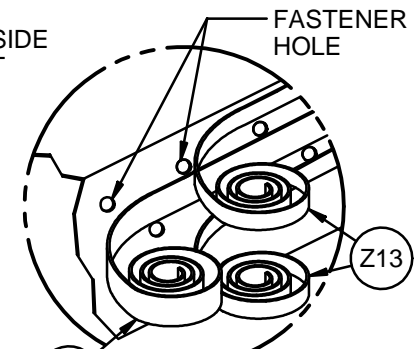

TYPE F

(Z13) (Z12) (Z13) (TYPE 'F')

This is the symbol used throughout the manual to indicate the locations where a type F seal is required.

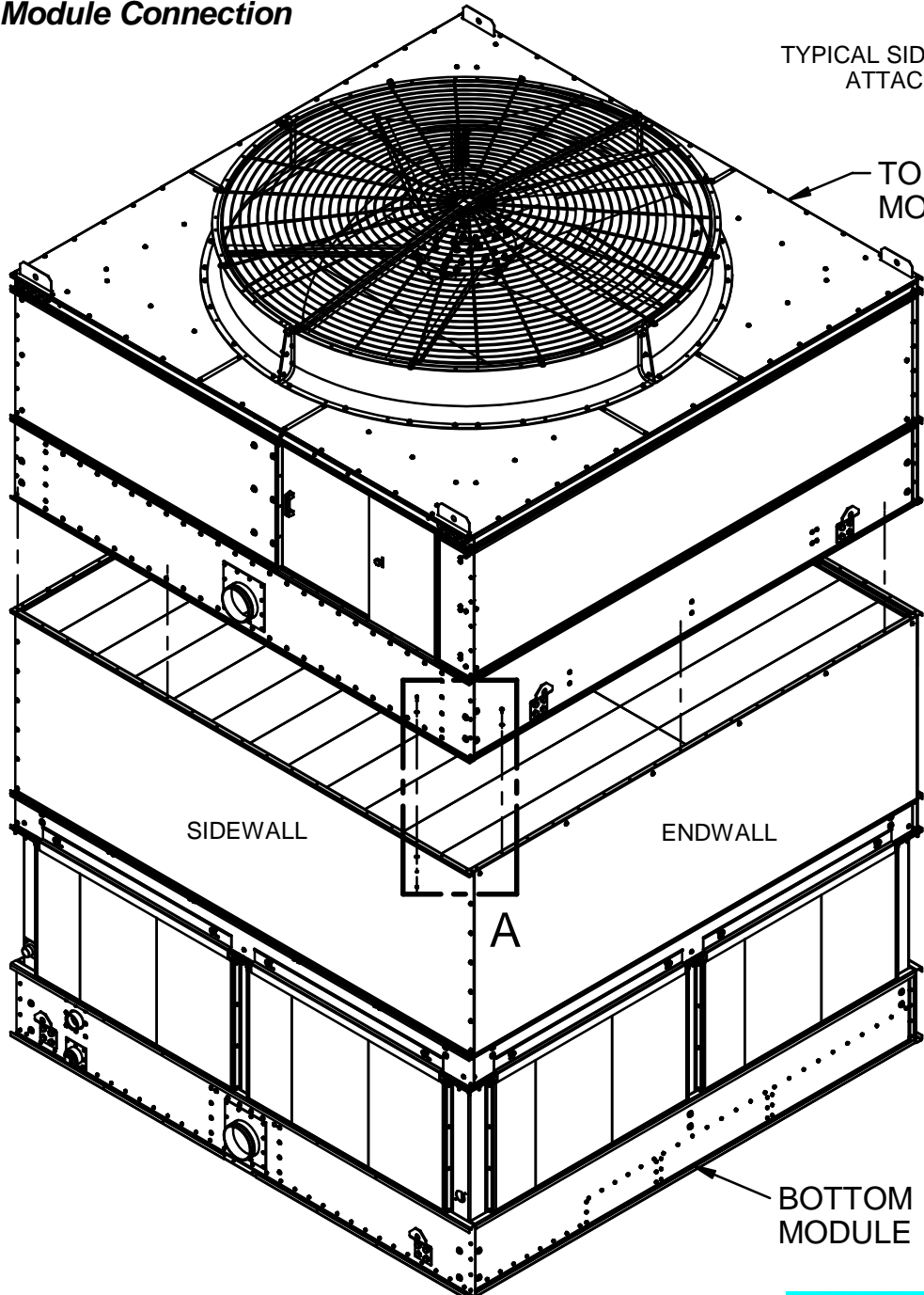

TYPICAL SIDEWALL ATTACHMENT

VM1

W24

TOP MODULE

TYPICAL ENDWALL ATTACHMENT

T07

W32

CLEAN ANY DIRT & DEBRIS FROM THE BOTTOM FLANGES OF THE TOP MODULE BEFORE HOISTING

TYPE 'D' Z12

W24

W48

X47

Z12 TYPE 'D'

Z11 FILL PANEL CORNER SEAMS WITH 3/8" [11mm] BEAD

DETAIL A

FIND NO.	DESCRIPTION
T07	TAP SCREW - 3/8" X 1"
VM1	HEX CAP SCREW - M8X25
W22	FLAT WASHER - M8
W32	SEALING WASHER - 3/8" [M10]
W48	LOCK WASHER - M8
X47	NUT - M8
Z11	TUBE SEALER
Z12	STRIP SEALER - 1" [25mm]

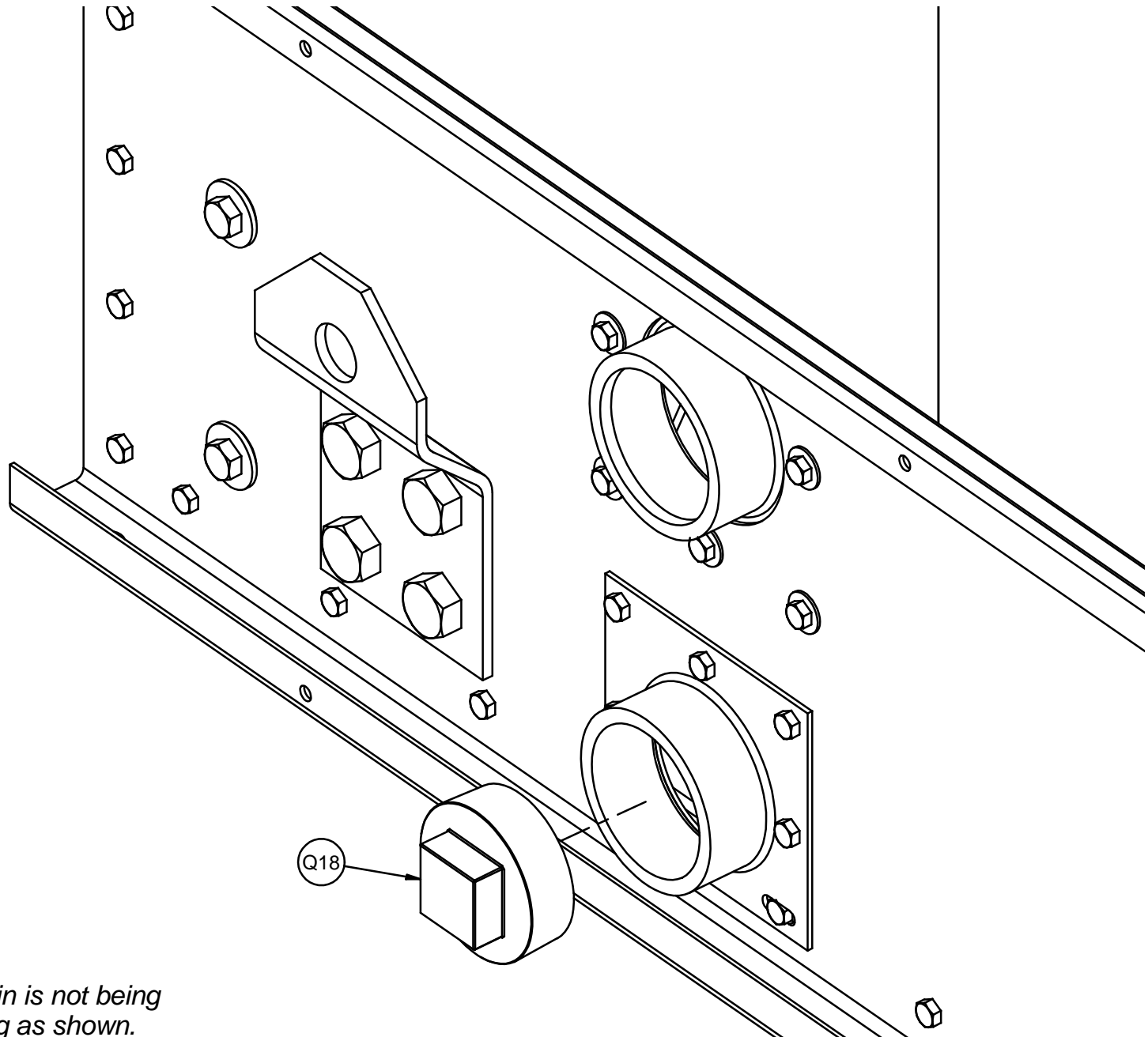

If the collection basin drain is not being plumbed, install drain plug as shown.

Collection Basin Options

Sump Outlet

MD5016 Field Installation

FIND NO.	DESCRIPTION
V09	HEX CAP SCREW - M10X40
W12	OVERSIZE WASHER - M10
W22	FLAT WASHER - M10
W32	SEALING WASHER - 3/8" [10mm]
X02	NUT - M10
Z11	TUBE SEALER

FASTENERS MUST BE STAINLESS STEEL IN STAINLESS BASINS

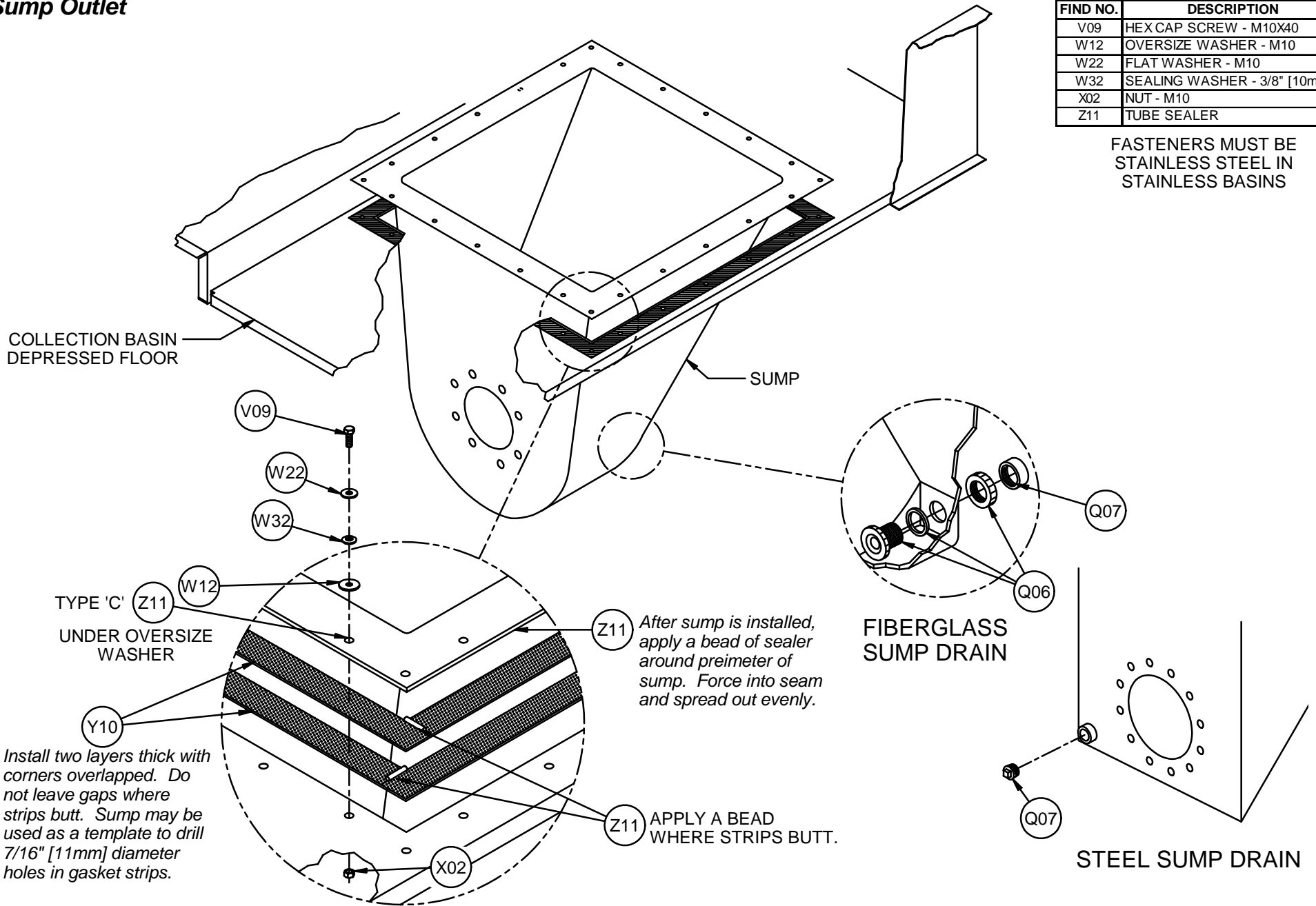

Install two layers thick with corners overlapped. Do not leave gaps where strips butt. Sump may be used as a template to drill 7/16" [11mm] diameter holes in gasket strips.

Sump Outlet

PIPING, SUPPORTS, DESIGN OF PIPING AND SUPPORTS, AND RESTRAINT OF LATERAL PIPING LOADS ARE THE RESPONSIBILITY OF OTHERS.

DO NOT SUPPORT PIPING FROM THE TOWER

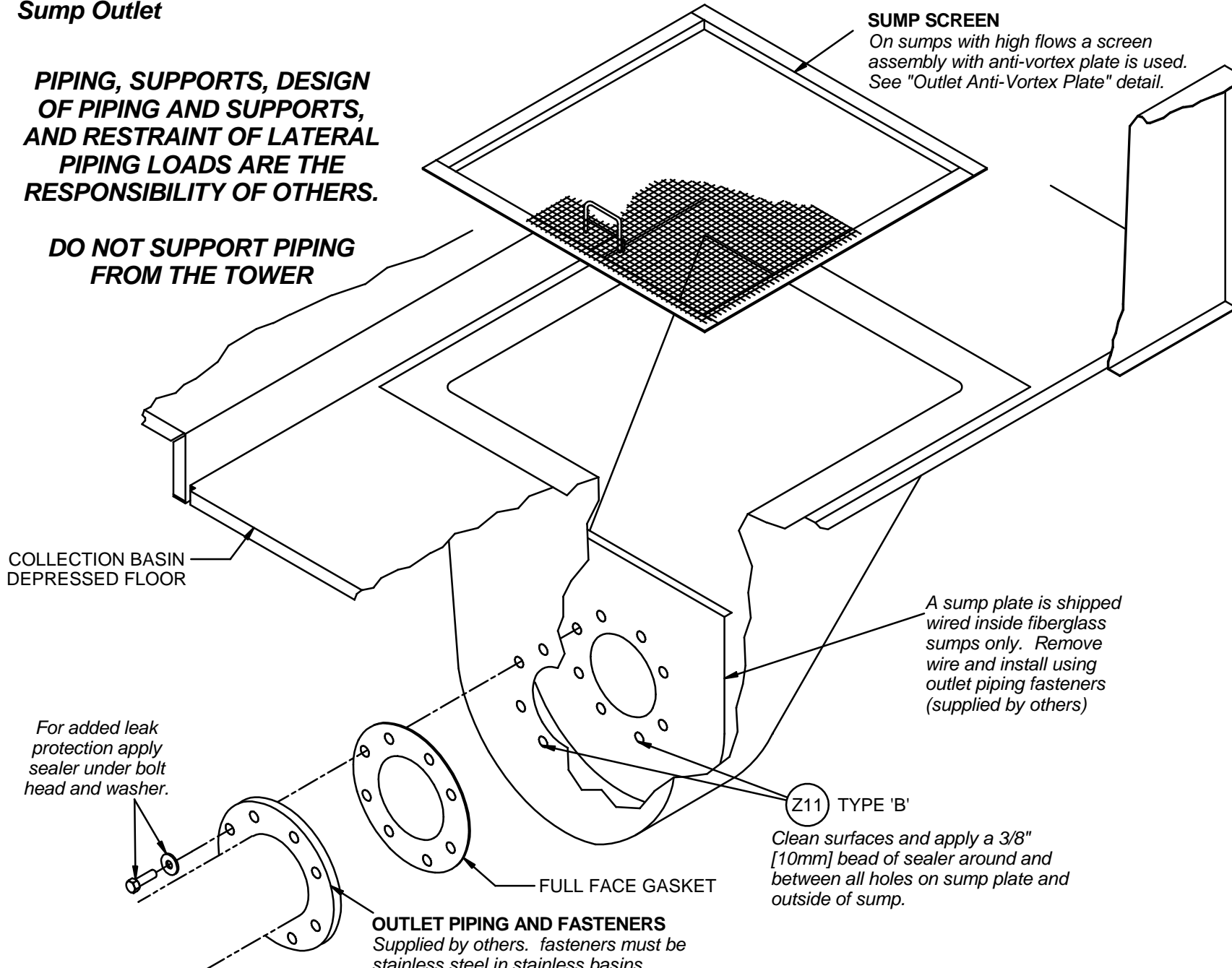

SUMP SCREEN

On sumps with high flows a screen assembly with anti-vortex plate is used. See "Outlet Anti-Vortex Plate" detail.

COLLECTION BASIN DEPRESSED FLOOR

For added leak protection apply sealer under bolt head and washer.

A sump plate is shipped wired inside fiberglass sumps only. Remove wire and install using outlet piping fasteners (supplied by others)

Z11 TYPE 'B'

Clean surfaces and apply a 3/8" [10mm] bead of sealer around and between all holes on sump plate and outside of sump.

FULL FACE GASKET

OUTLET PIPING AND FASTENERS
Supplied by others. fasteners must be stainless steel in stainless basins

Bottom Outlet / Equalizer / Inlet Bypass Piping

PIPING, SUPPORTS, DESIGN OF PIPING AND SUPPORTS, AND RESTRAINT OF LATERAL PIPING LOADS ARE THE RESPONSIBILITY OF OTHERS.

DO NOT SUPPORT PIPING FROM THE TOWER

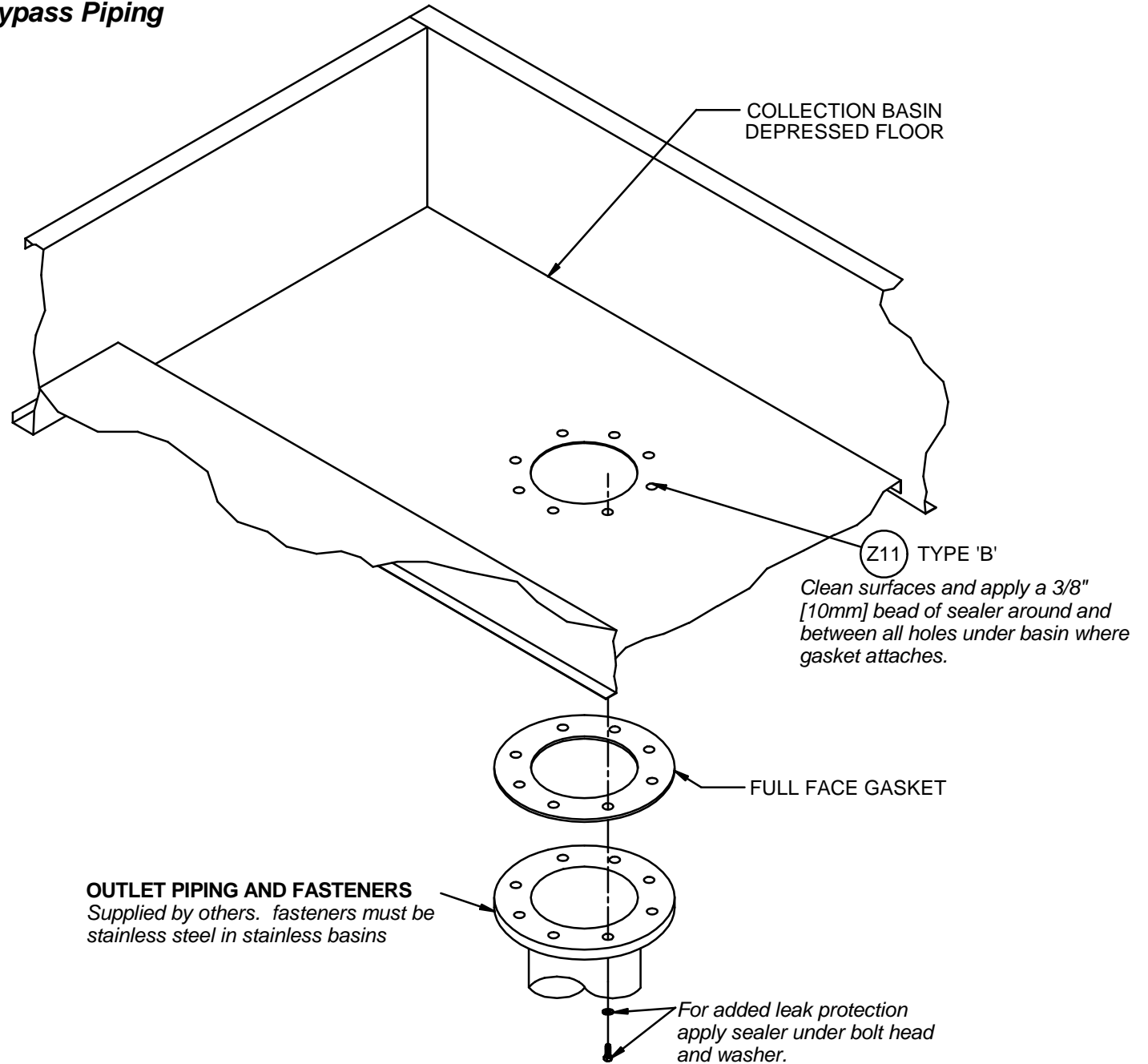

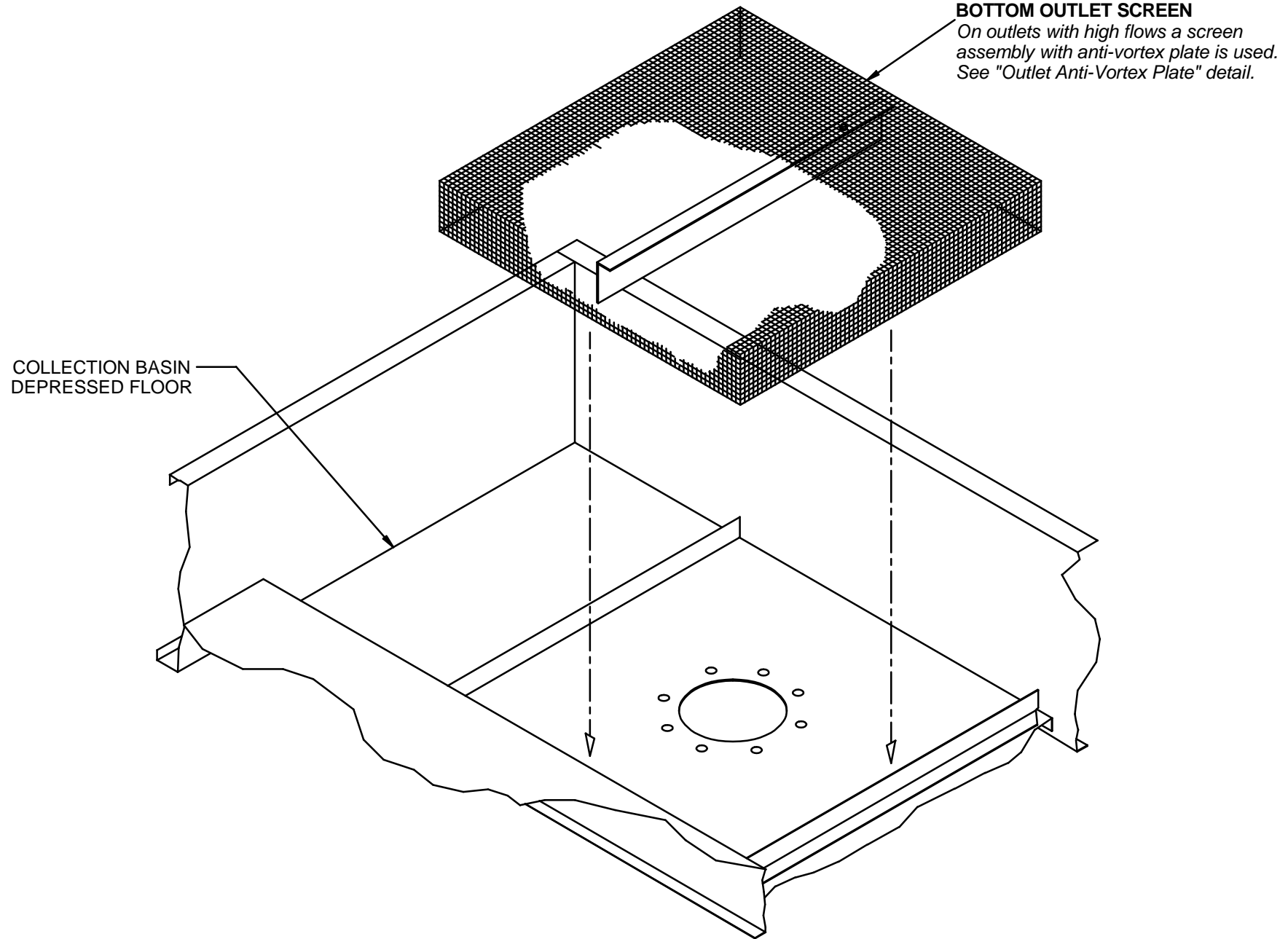

**ANTI-VORTEX PLATE &
SCREEN ASSEMBLY**
Used On outlets with high
flows. Center over Outlet

COLLECTION BASIN
DEPRESSED FLOOR

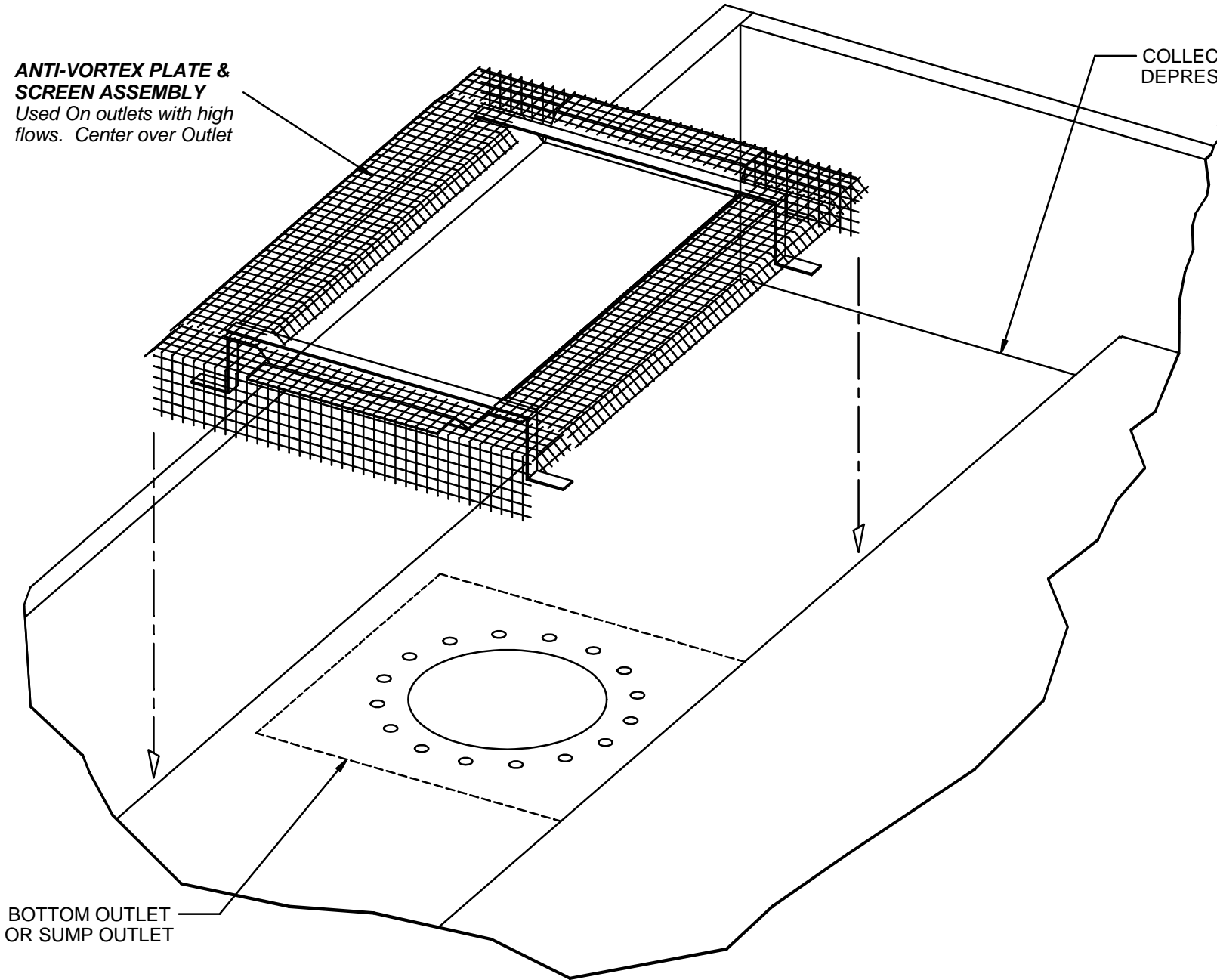

BOTTOM OUTLET
OR SUMP OUTLET

Collection Basin Options
Bottom Inlet Bypass Hood

MD5016 Field Installation

FIND NO.	DESCRIPTION
VM1	HEX CAP SCREW - M8X25
W24	FLAT WASHER - M8
W37	SEALING WASHER - 6/16" [8mm]
X47	NUT - M8
Z11	TUBE SEALER

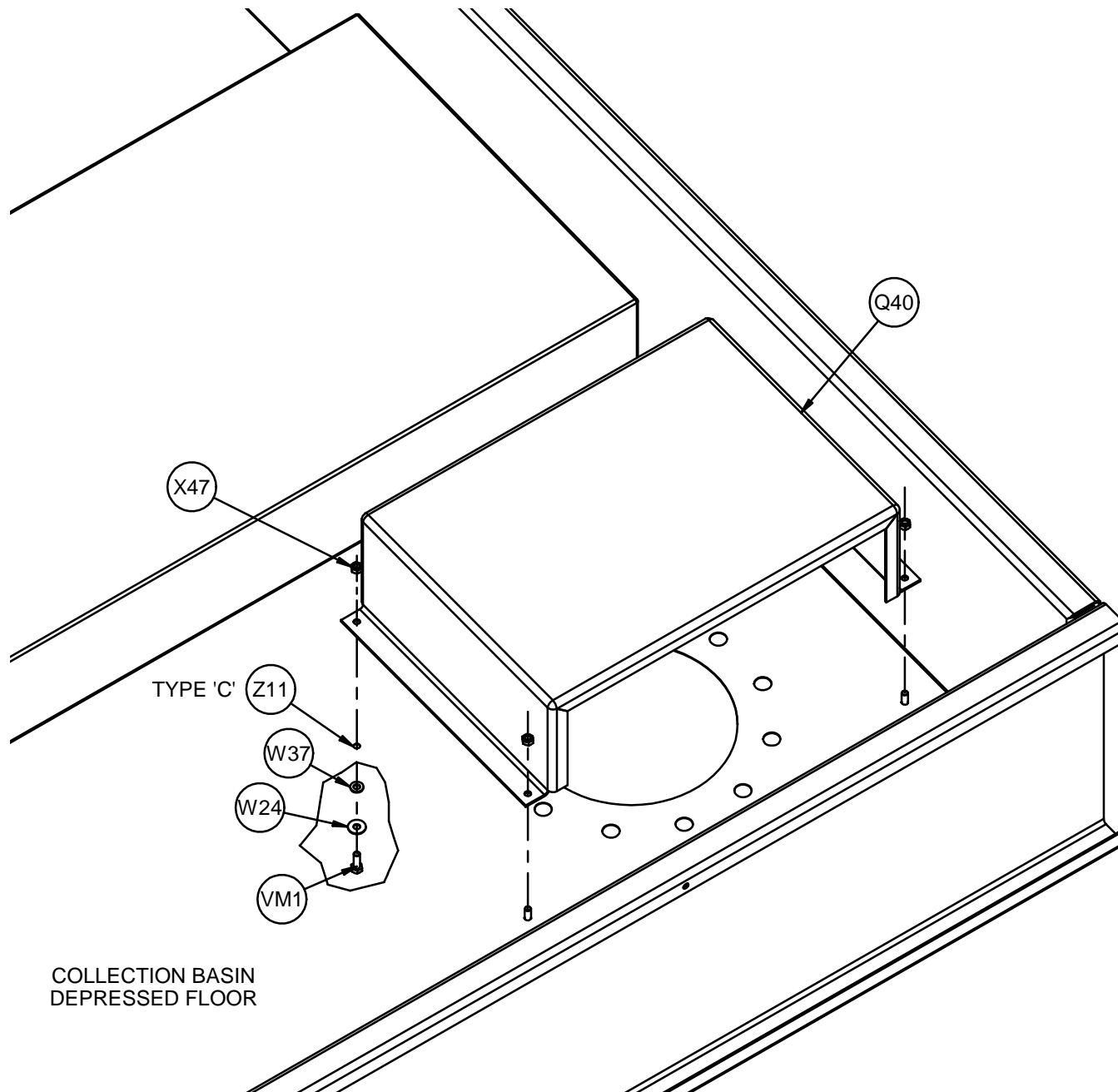

Flume

If collection basins of multiple towers are to be connected together, a flume is installed as shown.

Flume collars are shop installed in each tower along with temporary coverplates for shipment. Remove coverplates before continuing. Note that if a weir gate option (a removable plate used to isolate adjacent towers) has been purchased, the weir gate is shop installed, in one tower, for shipment. The weir gate will be reinstalled, in either tower, after installation of flume per the next page.

Note that towers must be aligned before attempting to install flume in place. Sealing of the flume connections is critical to prevent leaks. Apply a 1/2" [13mm] bead of sealer Z11 as indicated, around and between all holes on both flume collars. Install non-joggled flume corners Q11 first. Apply another bead of sealer around and between holes where joggle will overlap on flume. Complete flume installation by installing joggled flume corners Q15. If weir gate option is purchased, ends of flume corners must be flush to ensure a proper seal.

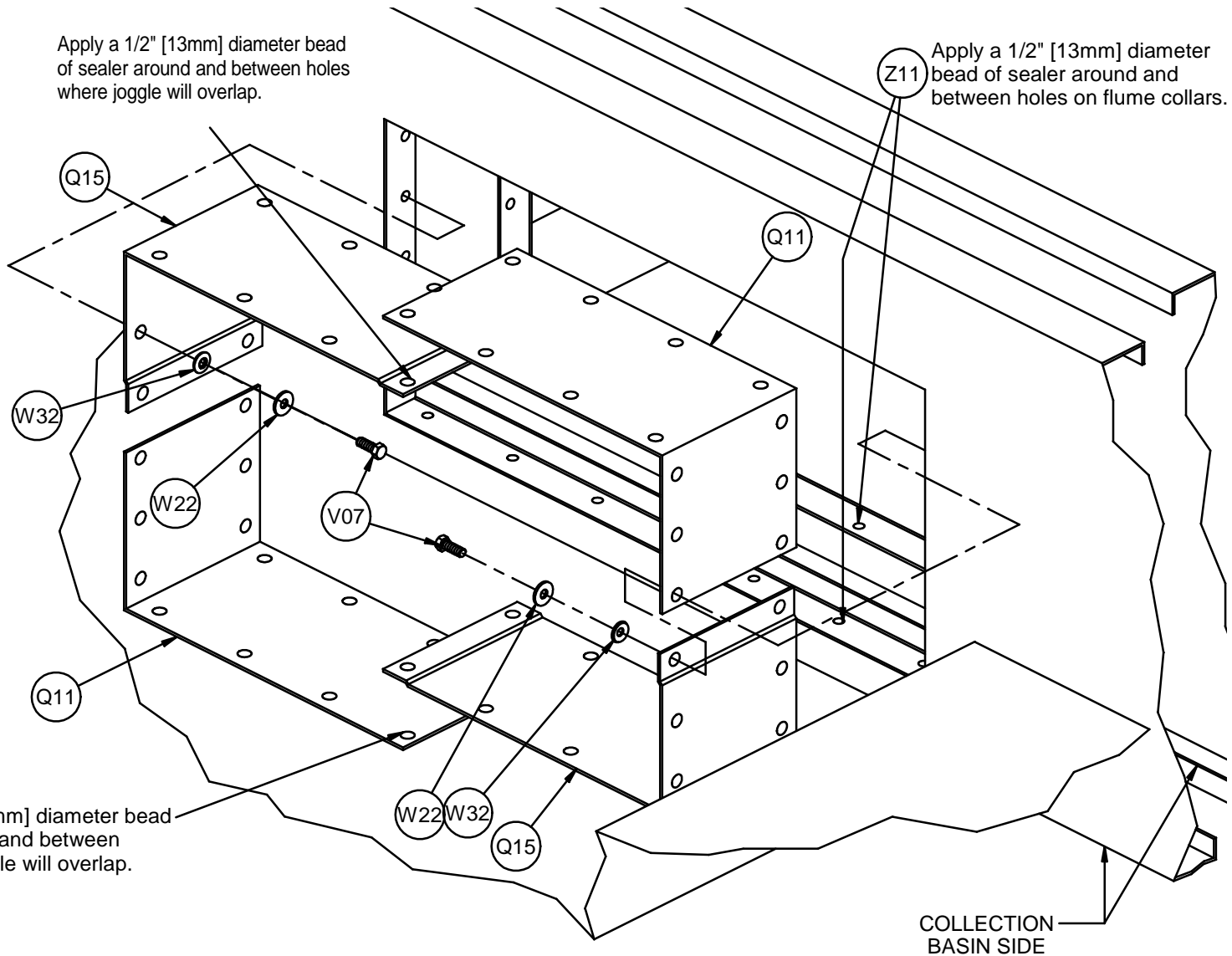

FIND NO.	DESCRIPTION
V07	HEX CAP SCREW - M10X25
W22	FLAT WASHER - M10
W32	SEALING WASHER - 3/8" [10mm]
X02	NUT - M10
Z11	TUBE SEALER

FASTENERS ARE
STAINLESS STEEL

IMPORTANT! Flumes are not a walking surface. Flumes that are 18" (457mm) long and longer have a caution decal which should be orientated on top.

FIND NO.	DESCRIPTION
W48	LOCK WASHER - M8
X47	NUT - M8

FASTENERS ARE
 STAINLESS STEEL

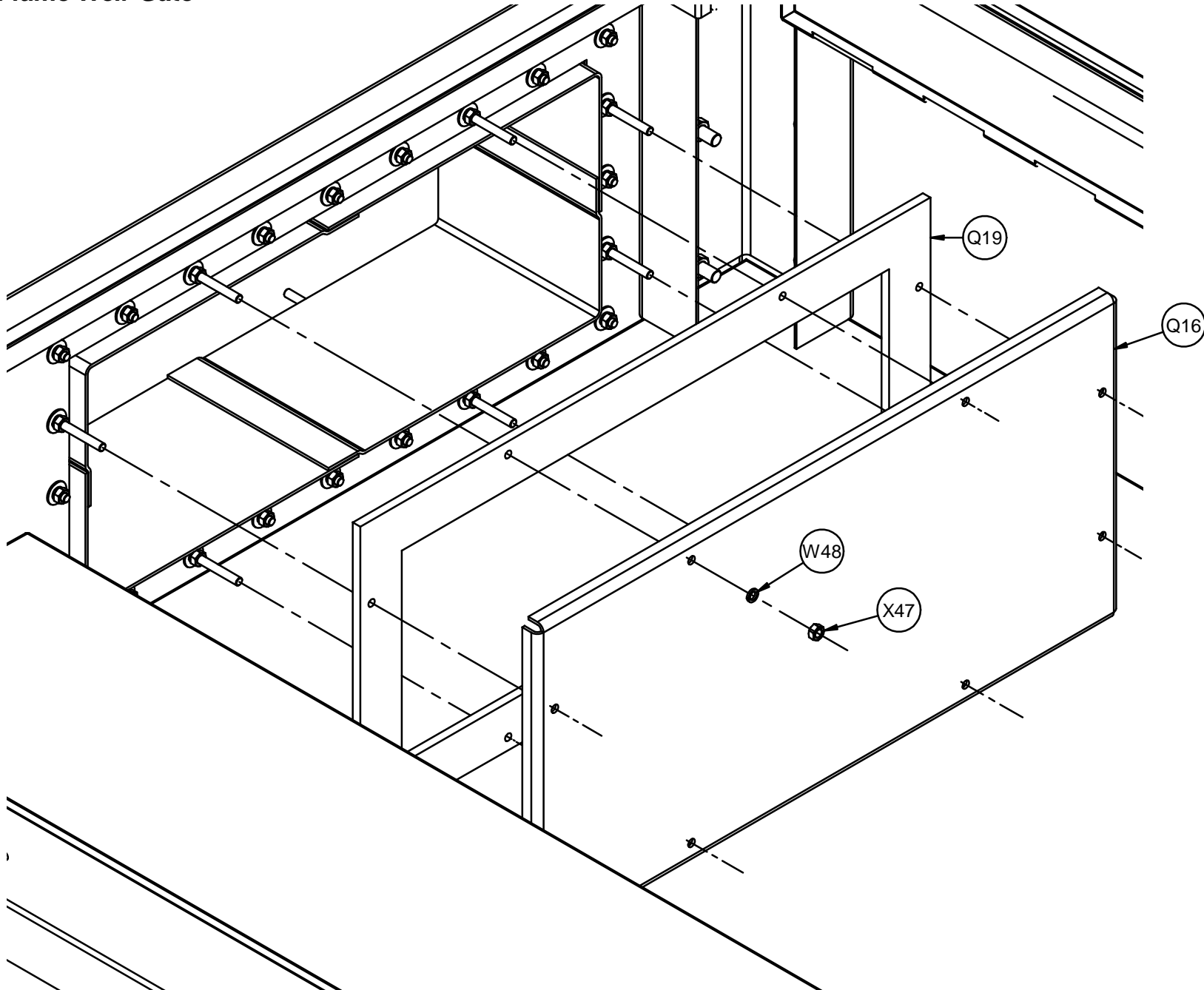

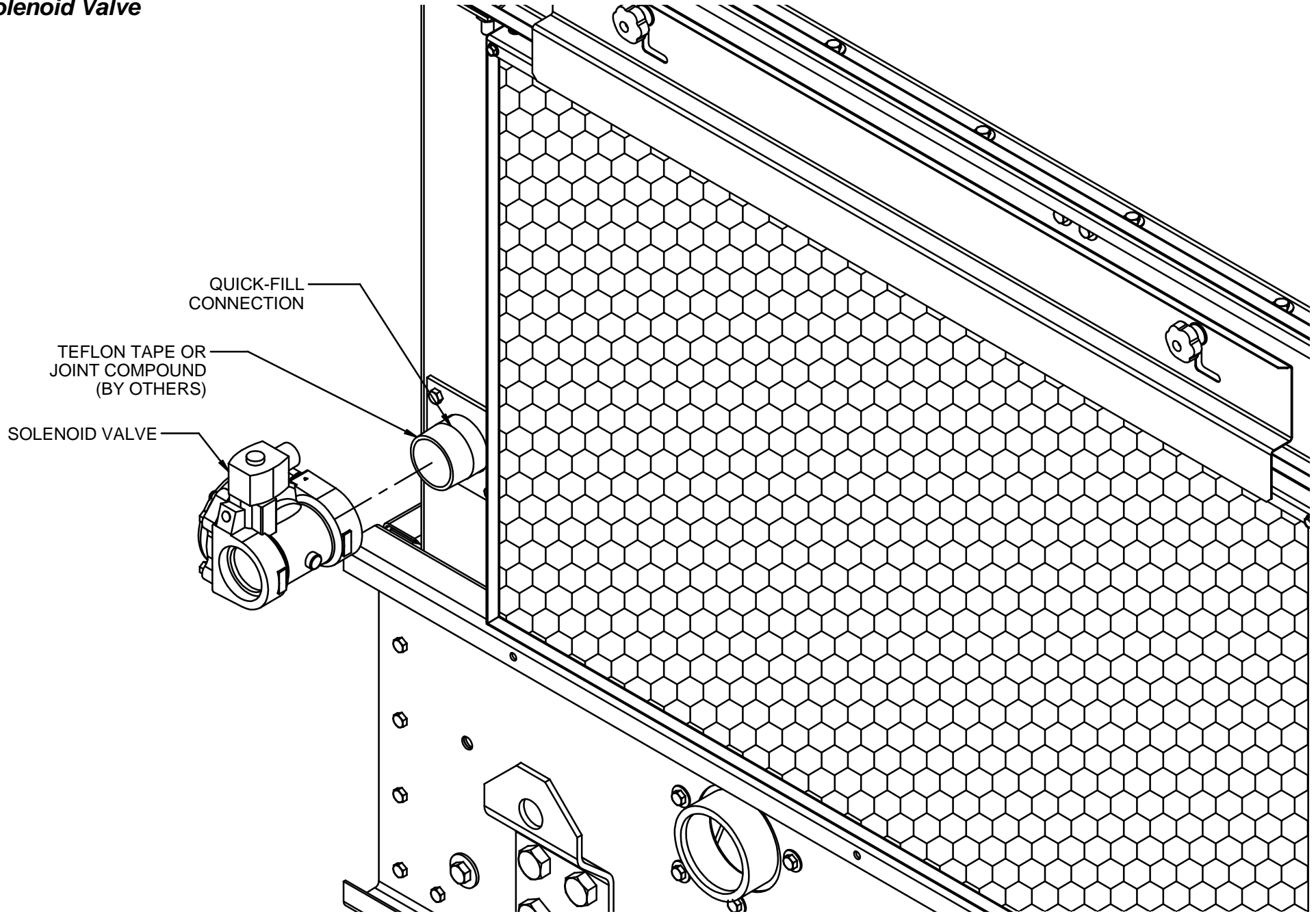

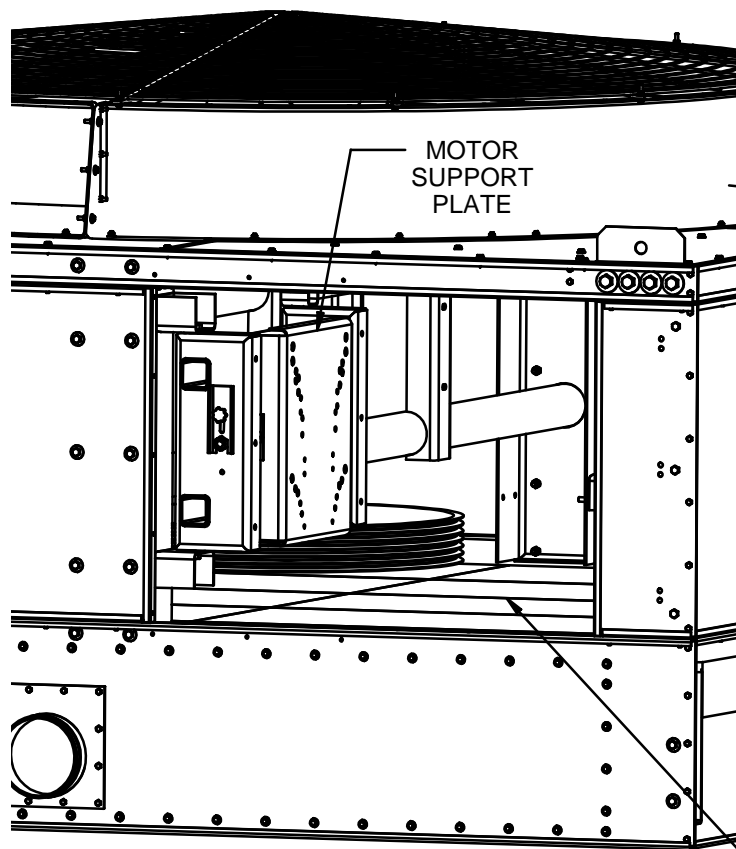

**VIEW FROM OPEN
ACCESS DOOR**

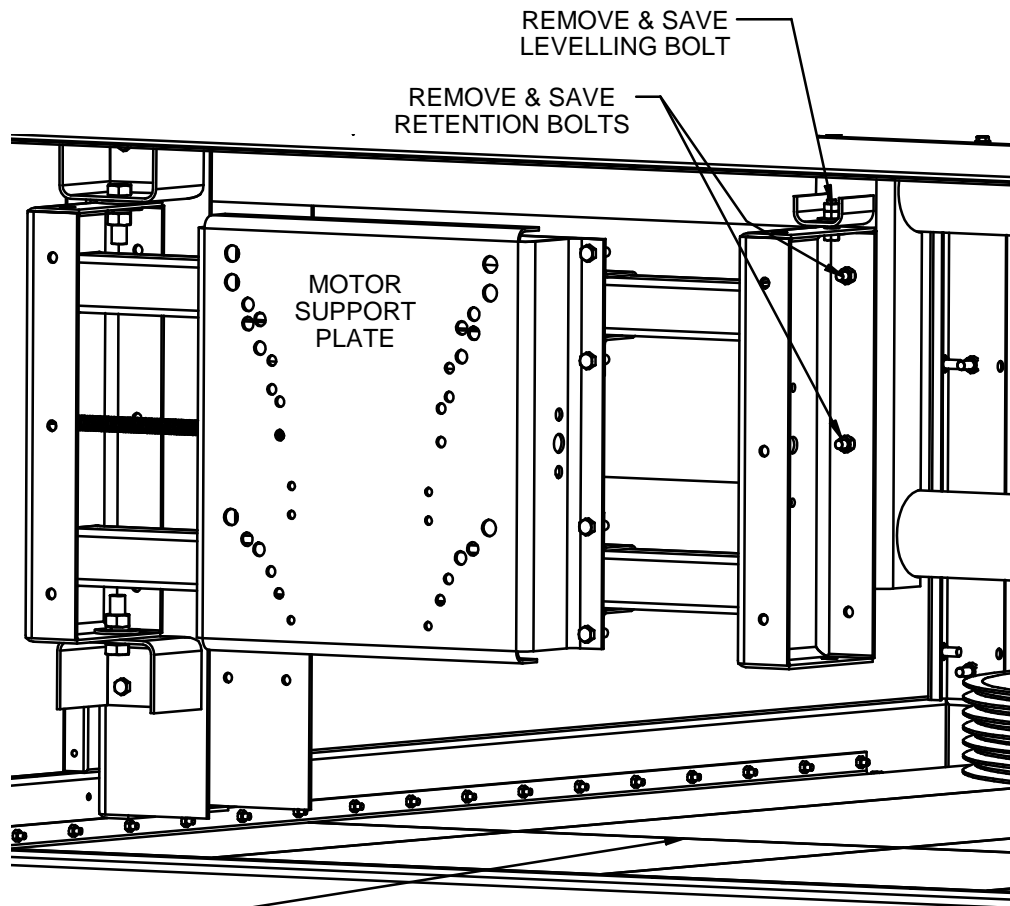

VIEW FROM INSIDE TOWER

PVC Drift Eliminators:

Lay a piece of plywood on top of the drift eliminators while working inside the tower to avoid damage. Remember to remove plywood when work is complete, or tower performance will suffer.

Belt Drive - Field Installed Motor Install Motor

MD5016 Field Installation

Rotate the motor plate out thru the access door opening. Install the motor with fasteners hand-tight to allow adjustment.

MOTOR ATTACHMENT HARDWARE				
MOTOR FRAME	FIND NUMBERS			
	A	B	C	D
NEMA 182T thru 215T	V11	W22	W02	X02
NEMA 254T thru 286T	V22	W23	W03	X03
NEMA 324T thru 365T	VB3	W29	W04	X05
NEMA 404T thru 405T	V39	W30	W05	X04
IEC 100L thru 132M	V11	W22	W02	X02
IEC 160M thru 180L	V22	W23	W03	X03
IEC 200L thru 225M	VB3	W29	W04	X05
IEC 250M	V39	W30	W05	X04

FIND NO.	DESCRIPTION
V11	HEX CAP SCREW - M10X65
V22	HEX CAP SCREW - M12X65
V39	HEX CAP SCREW - M20X90
VB3	HEX CAP SCREW - M16X90
W02	LOCK WASHER - M10
W03	LOCK WASHER - M12
W04	LOCK WASHER - M16
W05	LOCK WASHER - M20
W22	FLAT WASHER - M10
W23	FLAT WASHER - M12
W29	FLAT WASHER - M16
W30	FLAT WASHER - M20
X02	NUT - M10
X03	NUT - M12
X04	NUT - M20
X05	NUT - M16

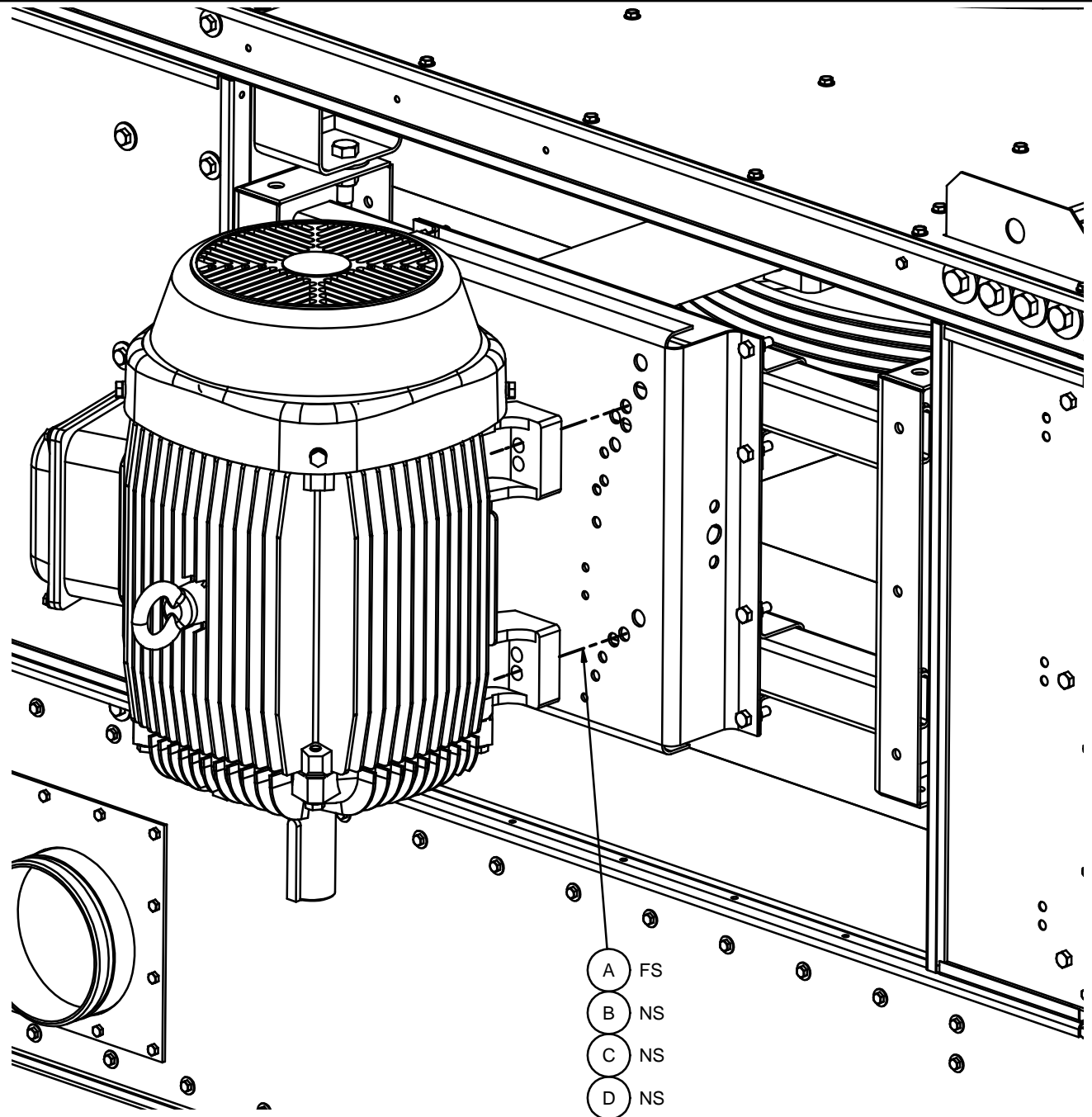

- A FS
- B NS
- C NS
- D NS

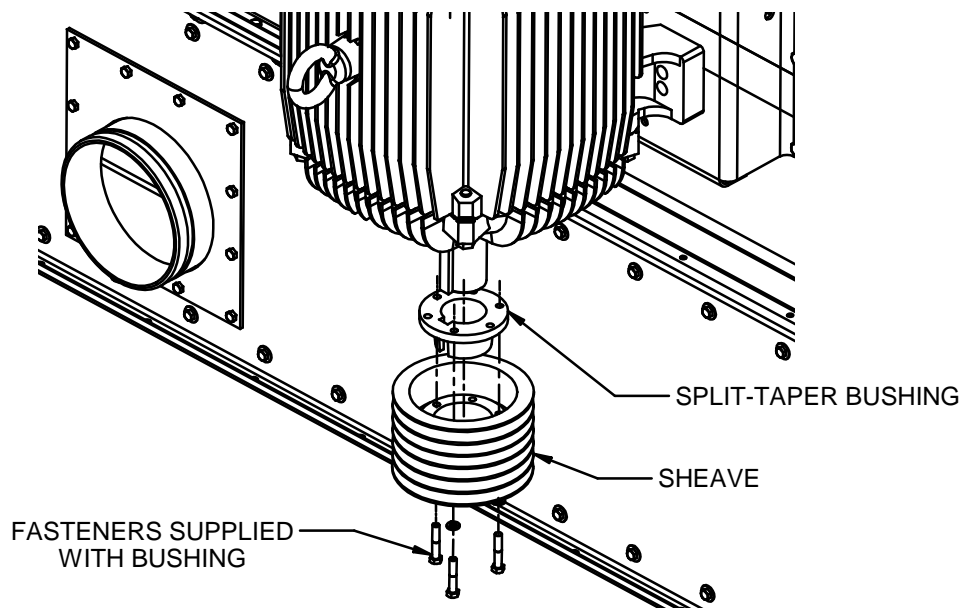

SPLIT-TAPER BUSHING

Thoroughly clean all the surfaces of the bushing, sheave and motor shaft. Install the sheave & bushing on the shaft in the orientation shown. Verify proper key is installed. Install bushing hardware through the sheave, threading into the bushing hand-tight. Level the top surfaces of the sheaves while maintaining full engagement of the shafts through the bushing bores. Use the bushing set screws to hold in place while adjusting level. **Refer to belt installation details on following pages for leveling instructions.** When leveling is complete, torque bushing cap screws per table. Values are for aluminum sheaves only. If sheave is cast iron, use the torque value supplied with the bushing.

Do not apply, oil, grease, anti-seize compounds, or other substances on the bushing, sheave, or shaft surfaces. Do not force bushing onto the shaft, or sheave onto bushing. Do not spread the bushing. Do not attempt to pull the bushing flange flush to the sheave. A clearance gap is normal.

SHEAVE ASSEMBLY TORQUE REQUIREMENTS	
SPLIT-TAPER BUSHING TYPE	TORQUE (ALUMINUM SHEAVE) FT-LBS [NEWTON-METERS]
SD	6 [8]
SK	13 [18]
SF	22 [30]
E	35 [48]

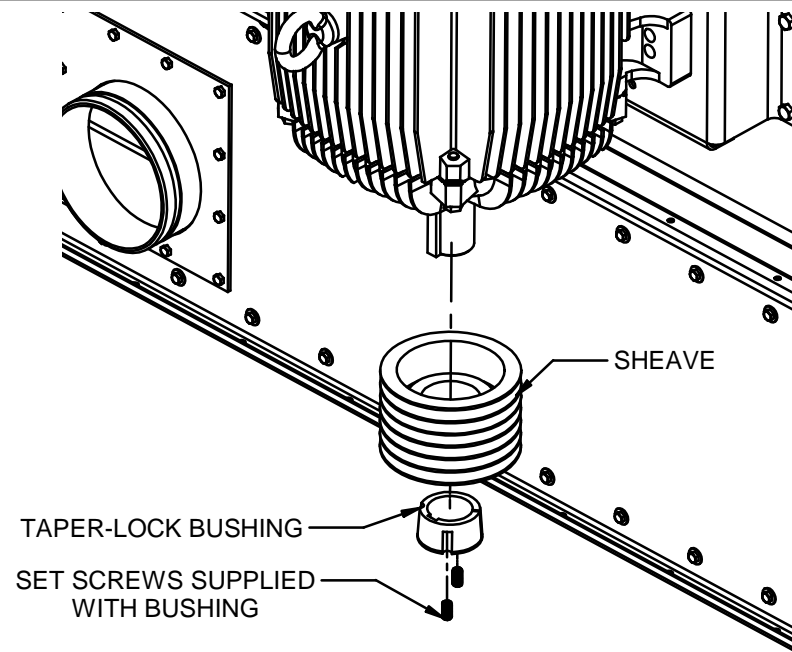

TAPER-LOCK BUSHING

Thoroughly clean all the surfaces of the bushing, sheave and motor shaft. Install the sheave & bushing on the shaft in the orientation shown. Verify proper key is installed. Install bushing set screws. Alternately torque the screws until the sheave and bushing tapers are seated together. Level the top surfaces of the fan & motor sheaves while maintaining full engagement of the shafts through the bushing bores. **Refer to belt installation details on following pages for leveling instructions.** When leveling is complete, torque bushing set screws per instructions supplied with the bushing. Tap the face of the bushing using a block or sleeve to prevent damage. This will ensure that the bushing is squarely seated in the sheave bore. Repeat torquing of set screws per instructions supplied with the bushing. Recheck set screw torque after initial drive run-in and periodically thereafter.

Do not apply, oil, grease, anti-seize compounds, or other substances on the bushing, sheave, or shaft surfaces. Do not force bushing onto the shaft, or sheave onto bushing. Do not spread the bushing.

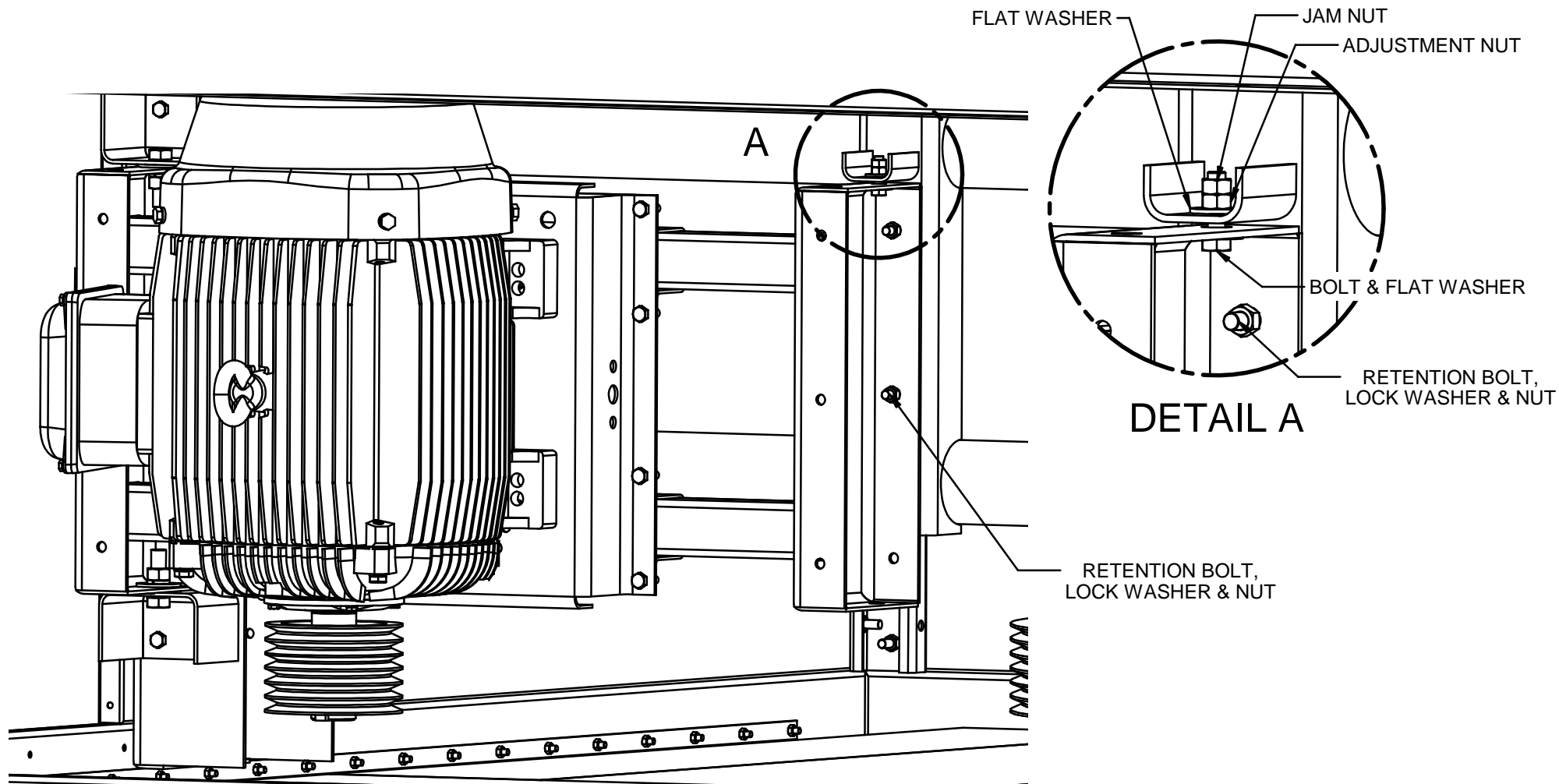

Rotate motor support back into the tower and reinstall support retention fasteners. The motor support may shift out of alignment due to the weight of the motor. Reinstall levelling bolt & tighten until motor support is level. Jam second nut against the first.

FASTENER TORQUE @ MOTOR ONLY		
BOLT DIAMETER	FASTENER TORQUE	
	FOOT-POUNDS (NEWTON-METERS) GALVANIZED (UNLUBRICATED)	STAINLESS STEEL (UNLUBRICATED)
10mm	30-32 (42-43)	34-36 (46-48)
12mm	64-66 (87-90)	85-90 (115-122)
16mm	135-140 (183-190)	125-130 (169-176)
20mm	220-230 (298-312)	195-205 (264-278)

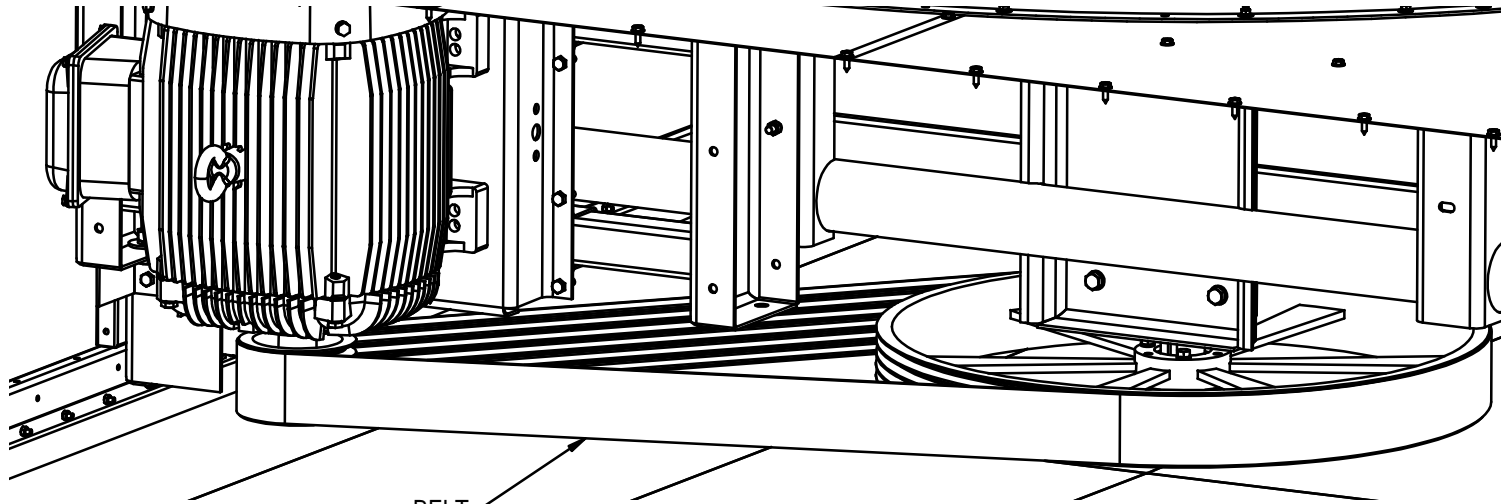
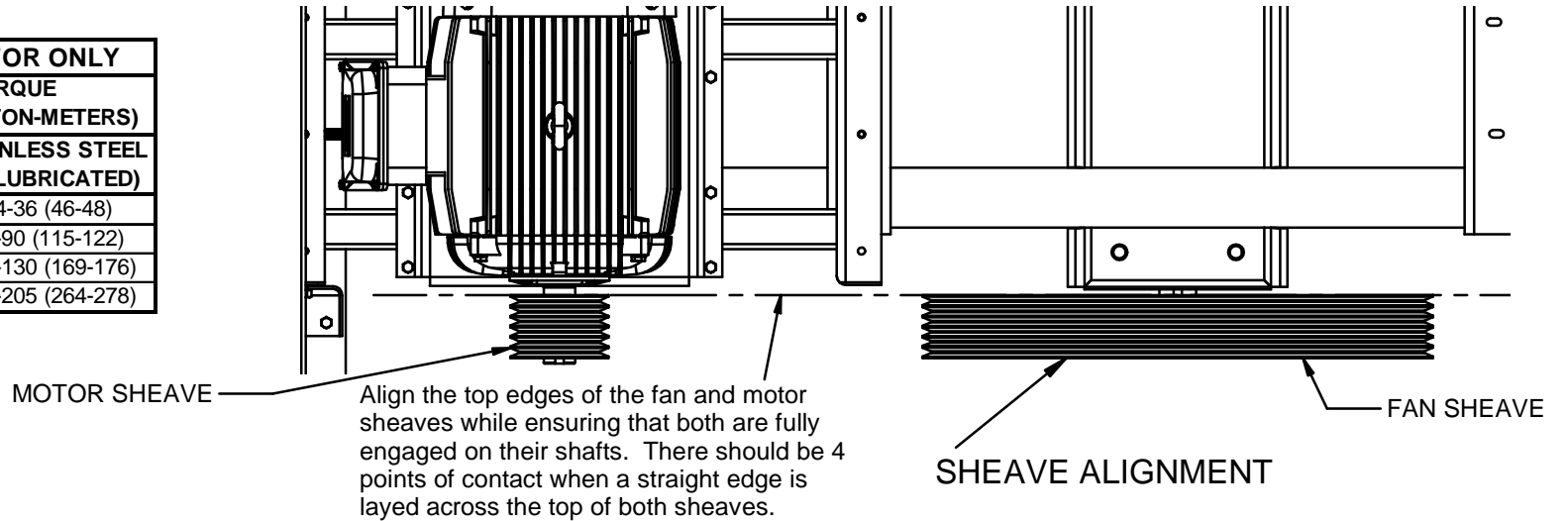

BELT:
The number of grooves on the sheaves and the number of ribs on th belt may vary. Always install the belt on the highest grooves of the sheaves

BELT INSTALLATION

Belt Tension

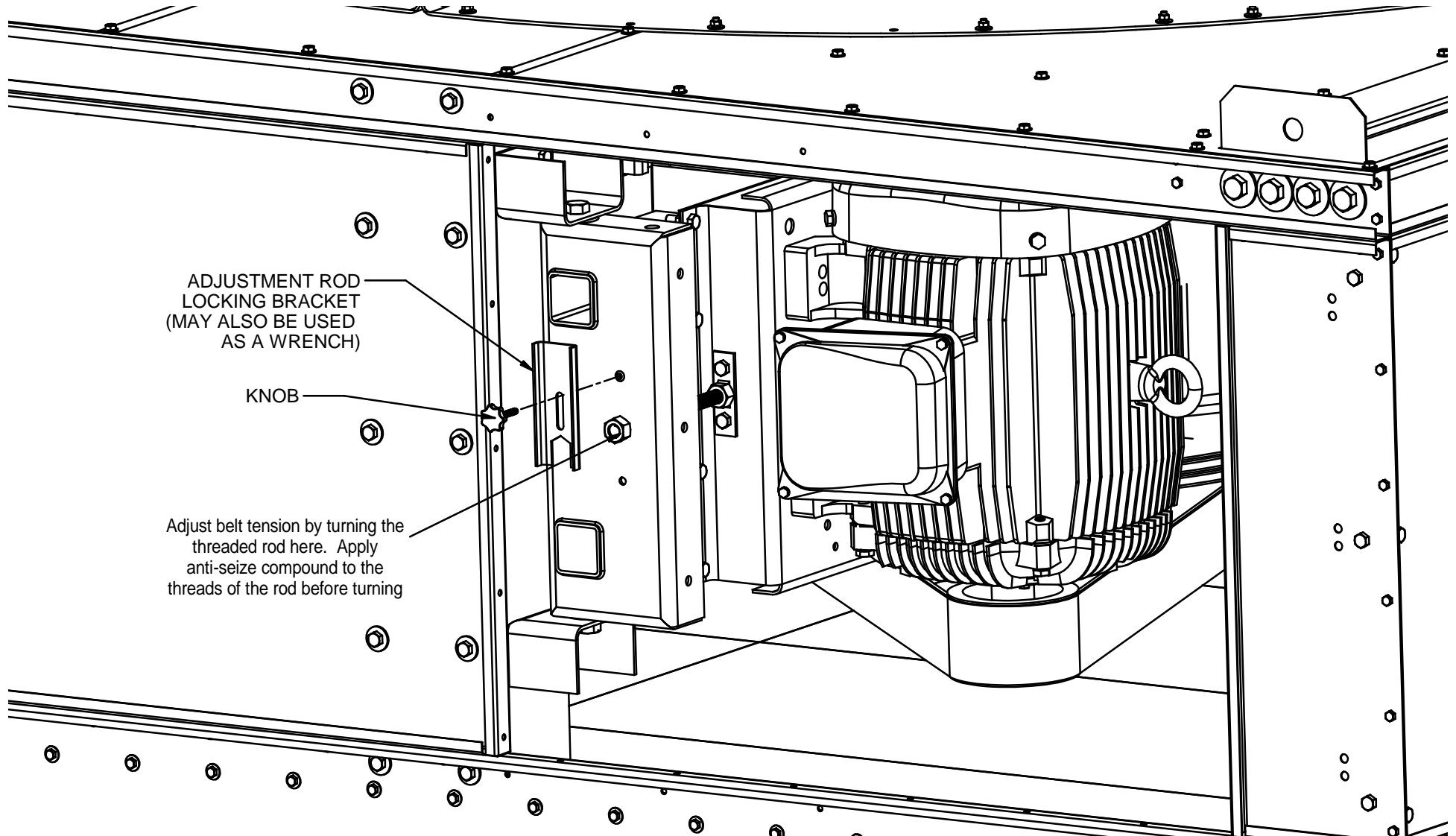

ADJUSTMENT ROD
LOCKING BRACKET
(MAY ALSO BE USED
AS A WRENCH)

KNOB

Adjust belt tension by turning the
threaded rod here. Apply
anti-seize compound to the
threads of the rod before turning

General Rules For Belt Tensioning

1. Ideal tension is the lowest tension at which the belt will not slip under peak load conditions
2. Over-tensioning shortens belt, motor bearing, and fan bearing life.
3. Keep belts free from foreign material which may cause slip.
4. Never apply belt dressing. this will damage the belt and cause early failure.