

LIGHTNIN

AN SPX BRAND

Packaging - Processing
Bid on Equipment
1-847-683-7720
www.bid-on-equipment.com

Series 500/600 Mixers

Designed for rugged, dependable service



SPX®

Just the Mixer you Need

The LIGHTNIN Series 500/600 mixers offer the features and flexibility you want, so you'll never have to buy more mixer than you need. For basic mixing applications, standard Series 500/600 mixers provide rugged, dependable service without having to pay for options you don't want or won't use. For more complex applications, Series 500/600 mixers have a host of options to help you tackle the most difficult processes. You and your LIGHTNIN sales engineer will simply select the impeller, motor, gear drive and seals that best meet your unique mixing needs.

Simplicity

Series 500/600 mixers feature fewer parts, resulting in simpler maintenance than other mixers.

The integral open-tank mounting base is bolted directly to the mounting surface without the need for a separate mounting plate.

All mechanical seal options are interchangeable for easy upgrade, and the Series 600 S includes a shaft coupling that allows seal change without removing the gear drive. Seal options cover a wide range of pressure and temperature requirements for wet- and dry-running applications.

Efficiency

A wide selection of high-efficiency impeller types lets you pick the one that best fits your process. The robust rigid shaft connection means a larger effective upper shaft diameter for longer shaft length with no bottom steady bearing. Drive design accommodates English or Metric mixer shafts, mechanical seals and NEMA or IEC motors.

Series 500/600 Options

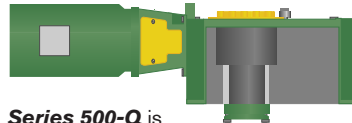

Series 500-Q is for open tank installations.

Series 500-C is a low profile stuffing box unit for low cost sealing of tank contents.

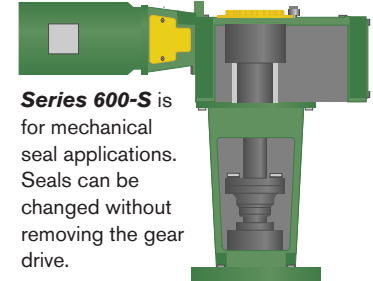

Series 600-S is for mechanical seal applications. Seals can be changed without removing the gear drive.

Reliability

Time-tested, case-hardened gearing and all-ductile iron castings give Series 500/600 mixers unsurpassed strength and durability. Large bearings provide years of trouble-free service. An innovative dry-well design ensures no oil leakage even under the worst conditions.

All Series 500/600 mixers are manufactured in LIGHTNIN plants that are certified to ISO 9001 standards and come with **LIGHTNIN's 100% process guarantee.**

Value

By selecting only the features you need for your unique process, Series 500/600 mixers deliver the best value for initial cost and total cost of ownership.

High-efficiency Impellers to Match your Process Needs



A510: General Purpose

New laser-designed impeller delivers true axial flow, high flow-per-horsepower, and can be custom-fit to your application.



A320: High-Viscosity

Fluid foil design reduces blend time by half and delivers better axial motion for 50% power saving compared to conventional pitch-blade turbines.



A315: Gas-Liquids-Solids

Improves yield by up to 50% in shear-sensitive processes such as fermentation. The A315 is the optimum impeller for applications involving mass transfer and solids suspension.

Model 500-Q

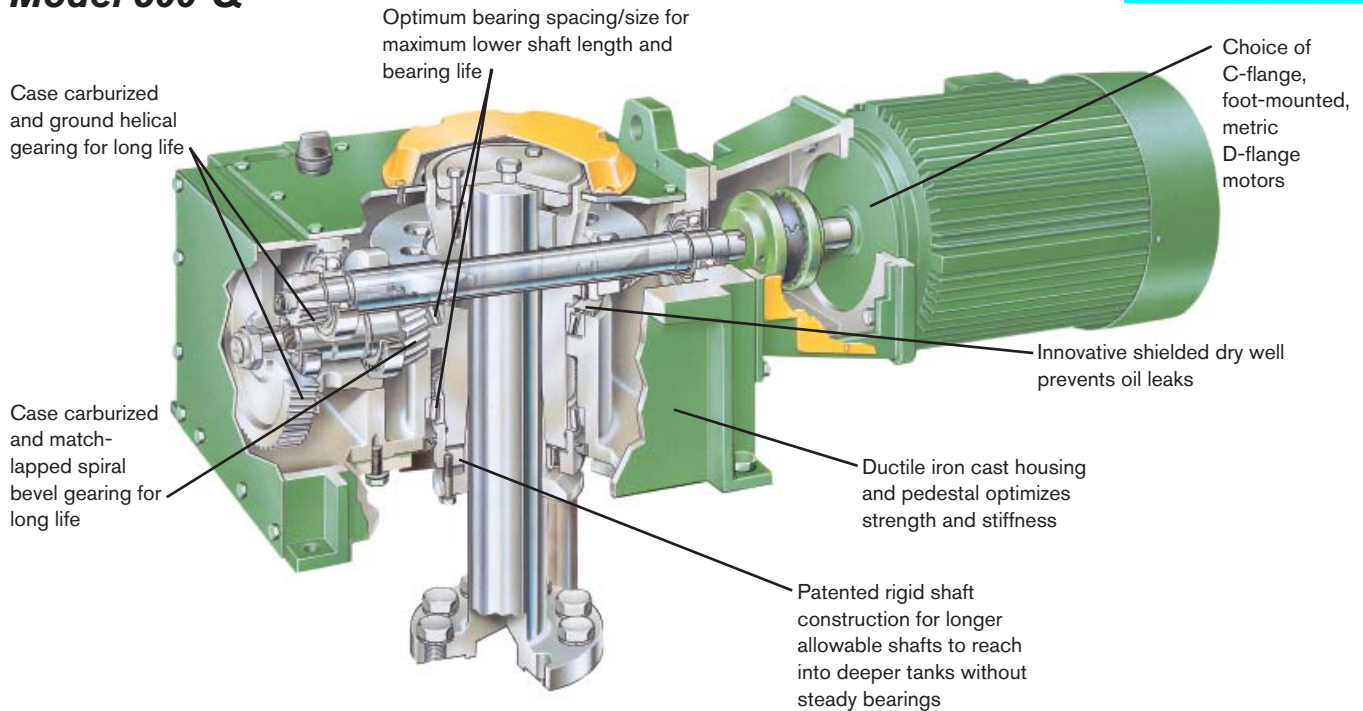

Model 600-S

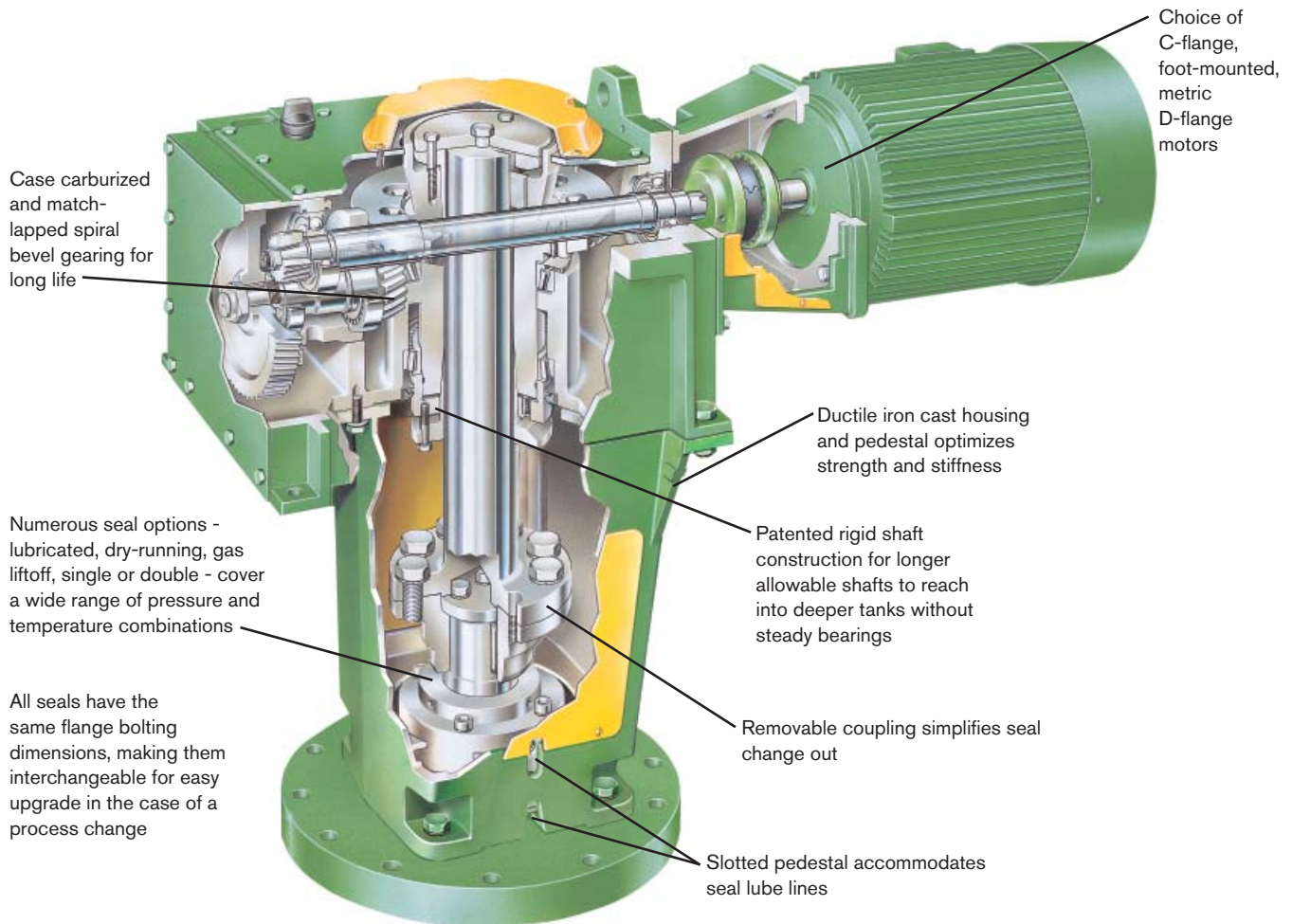

Model 500-Q

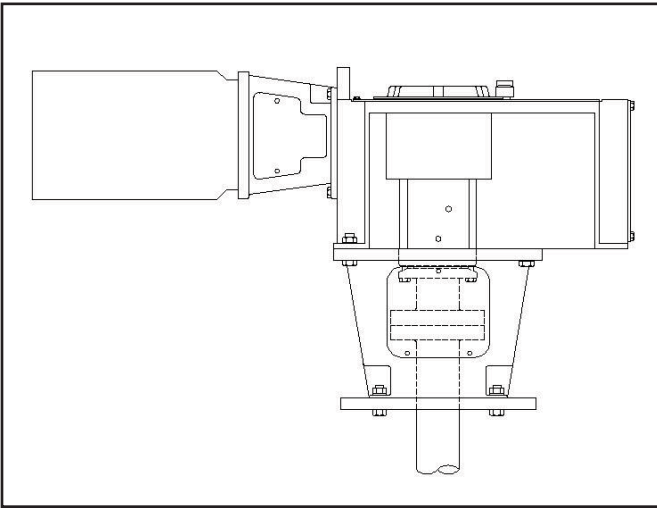

Model 500-C

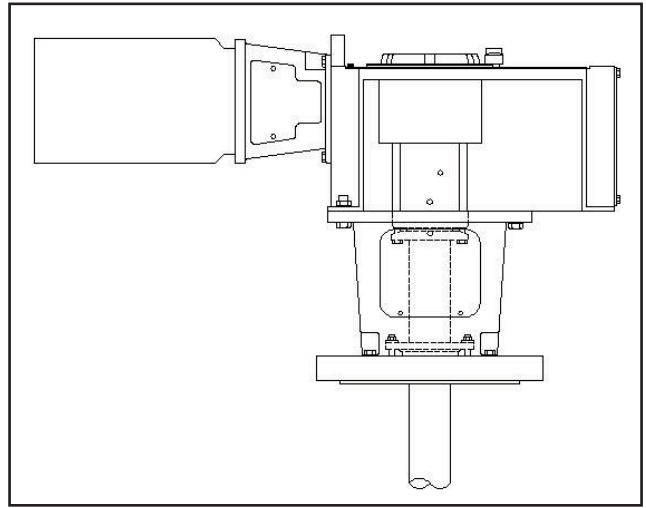

Service

SPX Process Equipment Services

- Repair Services
- Equipment Services
- PM/PDM Services
- Additional Services
 - Installation and Startup
 - Maintenance and Repair
 - Asset Management

For 24-hour response, call 1-888-MIX-BEST
(U.S. and Canada)

Call the SPX Process Equipment Experts

For more information about the LIGHTNIN 500/600 Series Mixers or to discuss your application, contact your local SPX Process Equipment Sales Representative.
Or visit our website at www.spxpe.com.
Or call 1-888-MIX-BEST (U.S. and Canada)

Model 600-S

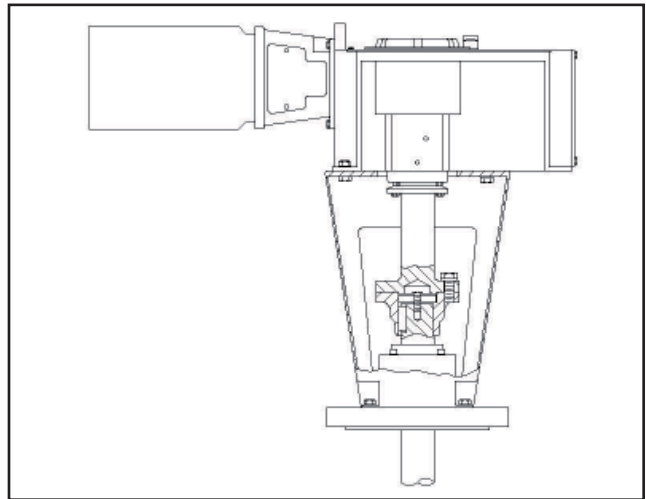

SPX®

PROCESS EQUIPMENT

SPX Process Equipment, LIGHTNIN Operation
135 Mt. Read Blvd., Rochester, NY 14611
Phone: (888) 649-2378 (MIX-BEST), (U.S. and Canada) or +1 (585) 436-5550
E-mail: LIGHTNIN@spx.com

For more information about our worldwide locations, approvals, certifications, and local representatives, please visit www.spxpe.com.

SPX Corporation reserves the right to incorporate our latest design and material changes without notice or obligation. Design features, materials of construction and dimensional data, as described in this bulletin, are provided for your information only and should not be relied upon unless confirmed in writing.

Packaging - Processing
Bid on Equipment
1-847-683-7720
www.bid-on-equipment.com