

Nettco S-Series Mixer

Sanitary Stainless Steel

Portable and Fixed Mount Mixers



Introducing A New Economical Portable and Fixed Mount Mixer System Configured To Meet Your Sanitary Needs.

Meets 3A Standards for the Food Industry

The Nettco S-Series sanitary mixer is available in a wide range of mixing and mounting configurations utilizing a unique modular assembly design. With one mixer it is possible to configure a clamp-on, open tank or sealed mixer design. This mixer can be quickly converted from one mounting arrangement to another. Modifying the mounting configuration can be accomplished in less than two minutes.



- Highest quality at a competitive price
- For new or existing tank sizes: 0.1 - 20 m³ (25 - 5,000 gal.)
- Designed for Dairy, Beverage, Oils, Prepared Foods and more
- Wide range of impellers and mounting options

Unique Modular Concept Features:

- Sanitary, all stainless steel design
 - 304 SS housing
 - Washdown (IP55), inverter ready motor
 - Proven planetary gearing – robust and reliable
 - Food grade lubricant
 - Unique, innovative modular design
 - Reverse-taper shaft attachment for added safety
 - Stainless Steel Motor, 0.37 - 2.2 Kw (1/2 - 3 HP)
 - Fully standardized product
- Direct and gear options for this global use mixer provides full range of shaft speeds (RPM)
 - 1450, 290, and 240 (50 Hz)
 - 1750, 350, and 280 (60 Hz)
- Shaft lengths up to 2100 mm (84")
- Simple, compact, 3A clean design available
- Economical
- Impellers from world's mixing technology leader
 - Multiple style impellers available
 - Hydrofoil, PBT and FP 100 (Marine Prop)

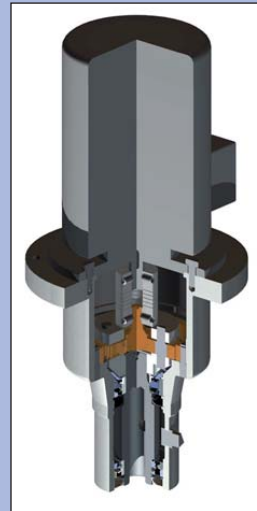

**Gear Drive
Section View**

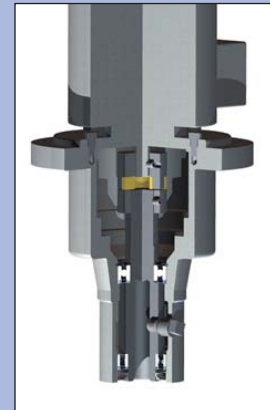

**Direct Drive
Section View**

Typical Product Applications



Dairy



**Prepared
Foods**



Beverage



Pharma



**Personal
Care**

Modular Design Features:



Clamp Module (P):

- Bolted onto base module
- Clamps to vessel
- Clamps to stand
- 0° or 20° horizontal mounting
- 0° to 90° vertical adjustment

Adjustable mounting – controls vessel contents swirl for improved mixing



Fixed-Mount Open Tank Module (Q):

Open Tank Flange Module

- Attaches to base module
- Use on open tanks where a seal is not required
- Vertical on center for baffled tanks
 - Vertical offset for unbaffled tanks
 - Can be angular mounted



Fixed-Mount Closed Tank Mechanical Seal Module (S):

Closed Tank Sealed Module

- Attaches to base module
- For closed tanks with seal requirements
- ANSI or DIN Flange Mount
 - Single dry-running mechanical seal good for 340 kPa (50 PSI) (allowable tank pressure)



Fixed-Mount Closed Tank Lip Seal Module (L):

Closed Tank Sealed Module

- Attaches to base module
- For closed tanks with seal requirements
- ANSI or DIN Flange Mount Lip Seal
 - Food Grade lip seal good for 170 kPa (25 PSI) (allowable tank pressure)

Modular Mixing System:



Base Module

0° Clamp Module

20° Clamp Module

Flange Module

Lip Seal Module

Mechanical Seal Module



Clamp Mount



Fixed Mount - Open

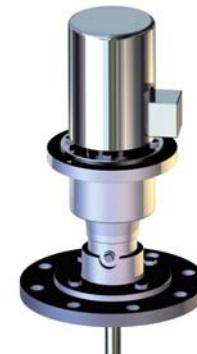

Fixed Mount - Lip Seal



Fixed Mount - Mechanical Seal

Sanitary Mixer “Blend Time Selection Table”

60 HZ Selections

		VISCOSITY/cP or mPa-s						
		1	100	250	500	1000	2500	5000
TANK VOLUME/GALLONS	<25	MS1_1 (1) 1 3.6 FP	MS1_1 (1) 1 3.6 FP	MS1_1 (1) 1 3.6 FP	MS1_1 (1) 1 3.6 FP	MS1_1 (1) 1 3.3 FP	MS6_1 (2) 1 8.9 FP	MS6_1 (3) 1 7.7 FP
	<50	MS1_1 (1) 1 3.6 FP	MS1_1 (1) 1 3.6 FP	MS1_1 (2) 1 3.6 FP	MS1_1 (2) 1 3.6 FP	MS5_1 (1) 1 10.0 H	MS6_1 (3) 1 8.9 FP	MS6_1 (3) 1 10.0 FP
	<100	MS1_1 (2) 1 3.6 FP	MS1_1 (2) 1 3.6 FP	MS1_1 (2) 1 3.8 FP	MS5_1 (1) 1 11.2 H	MS5_1 (2) 1 10.0 H	MS6_1 (3) 1 10.0 FP	MS6_2 (5) 2 10.0 FP
	<200	MS1_1 (3) 1 3.6 FP	MS1_1 (3) 1 3.6 FP	MS5_1 (1) 1 11.2 H	MS5_1 (2) 1 11.2 H	MS6_1 (3) 2 11.2 H	MS6_2 (6) 2 10.5 FP	MS6_3 (9) 2 10.5 FP
	<500	MS1_1 (6) 1 3.8 FP	MS5_1 (3) 1 11.2 H	MS5_1 (4) 1 11.2 H	MS5_1 (5) 1 11.8 H	MS6_1 (6) 2 12.8 H	MS6_3 (12) 2 13.6 H	MS6_4 (11) 2 11.4 FP
	<1000	MS5_1 (4) 1 11.2 H	MS5_1 (7) 1 11.2 H	MS5_1 (6) 1 11.8 H	MS5_1 (7) 1 12.8 H	MS6_2 (10) 1 13.6 H	MS6_3 (21) 2 13.6 H	MS6_5 (15) 2 13.1 FP
	<2000	MS5_1 (7) 1 11.2 H	MS5_1 (14) 1 11.2 H	MS6_1 (12) 2 12.8 H	MS6_2 (17) 2 13.6 H	MS6_3 (22) 2 14.5 H	MS6_4 (33) 2 15.1 H	
	<3000	MS6_1 (11) 2 11.8 H	MS6_1 (16) 2 12.8 H	MS6_2 (18) 2 13.6 H	MS6_3 (20) 2 14.5 H	MS6_4 (27) 2 15.1 H	MS6_5 (42) 2 15.6 H	
	<5000	MS6_1 (14) 2 12.8 H	MS6_2 (23) 2 13.6 H	MS6_3 (24) 2 14.5 H	MS6_4 (27) 2 15.1 H	MS6_4 (38) 2 15.1 H		

Legend:

Series	Drive Ratio	Mounting	Motor Code	HP/kW
Nettco MS	1	P	1	(0.5/0.37)
	5	Q	2	(0.75/0.55)
	6	L	3	(1/0.75)
		S*	4	(1.5/1.1)
			5	(2/1.5)
			6	(3/2.2)

Chart Reference:

Model Design		
Blend Time		
No. Impeller	Imp. Dia.	Imp. Type

FP = FP-100, H = Hydrofoil

Tank height to diameter ratio 0.8 - 1.2
 Liquids with Newtonian viscosity characteristics
 S.G. difference of liquids <0.1
 Use for mild blending applications
 Maximum density 1.10 g/cm³
 Maximum viscosity ratio - 10:1 (>250cP)
 Mixer in operation during filling and emptying

Example: MS1Q2



*Direct Drive not available with seal.

Sanitary Mixer “Blend Time Selection Table”

50 HZ

		VISCOSITY/cP or mPa-s						
		1	100	250	500	1000	2500	5000
TANK VOLUME/LITRES	<100	MS1_1 (1) 1 104 FP	MS1_1 (1) 1 104 FP	MS1_1 (1) 1 104 FP	MS1_1 (1) 1 104 FP	MS1_1 (1) 1 97 FP	MS5_1 (2) 1 254 FP	MS5_1 (2) 1 226 FP
	<250	MS1_1 (1) 1 104 FP	MS1_1 (1) 1 104 FP	MS1_1 (2) 1 104 FP	MS1_1 (2) 1 104 FP	MS5_1 (1) 1 325 H	MS5_1 (3) 1 254 FP	MS5_1 (3) 1 239 FP
	<500	MS1_1 (2) 1 104 FP	MS1_1 (2) 1 104 FP	MS5_1 (1) 1 325 H	MS5_1 (1) 1 325 H	MS5_1 (3) 2 285 H	MS5_2 (4) 2 239 FP	MS5_2 (5) 2 226 FP
	<1000	MS1_1 (4) 1 104 FP	MS5_1 (2) 1 325 H	MS5_1 (2) 1 325 H	MS5_1 (2) 1 325 H	MS5_1 (5) 2 285 H	MS5_3 (7) 2 325 H	MS5_3 (7) 2 239 FP
	<1500	MS1_1 (5) 1 104 FP	MS5_1 (3) 1 325 H	MS5_1 (3) 1 325 H	MS5_1 (3) 1 325 H	MS5_1 (7) 2 285 H	MS5_3 (10) 2 325 H	MS5_3 (9) 2 239 FP
	<2000	MS1_1 (7) 1 104 FP	MS5_1 (3) 1 325 H	MS5_1 (4) 1 325 H	MS5_1 (5) 1 325 H	MS5_1 (8) 2 285 H	MS5_3 (12) 2 325 H	MS5_4 (11) 2 267 FP
	<2500	MS5_1 (3) 1 325 H	MS5_1 (5) 1 325 H	MS5_1 (5) 1 325 H	MS5_1 (5) 1 325 H	MS5_2 (7) 1 368 H	MS5_3 (16) 2 325 H	MS5_5 (11) 2 290 FP
	<3750	MS5_1 (4) 1 325 H	MS5_1 (7) 1 325 H	MS5_1 (6) 1 325 H	MS5_1 (7) 1 325 H	MS5_2 (10) 1 368 H	MS5_3 (21) 2 325 H	MS5_5 (15) 2 290 FP
	<5000	MS5_1 (5) 1 325 H	MS5_1 (9) 1 325 H	MS5_1 (9) 2 300 H	MS5_2 (13) 2 325 H	MS5_3 (14) 2 345 H	MS5_4 (26) 2 345 H	
	<7500	MS5_1 (6) 1 325 H	MS5_1 (14) 1 325 H	MS5_1 (13) 2 300 H	MS5_2 (17) 2 325 H	MS5_3 (23) 2 345 H	MS5_4 (37) 2 345 H	
	<10000	MS5_1 (8) 1 325 H	MS5_1 (17) 2 300 H	MS5_2 (14) 2 325 H	MS5_3 (18) 2 25 H	MS5_4 (24) 2 368 H	MS5_5 (37) 2 384 H	
	<12500	MS5_1 (11) 2 300 H	MS5_2 (17) 2 325 H	MS5_3 (18) 2 325 H	MS5_4 (20) 2 384 H	MS5_4 (28) 2 368 H		
	<15000	MS5_1 (12) 2 300 H	MS5_2 (21) 2 325 H	MS5_3 (20) 2 325 H	MS5_4 (22) 2 384 H	MS5_4 (32) 2 368 H		
	<20000	MS5_1 (16) 2 300 H	MS5_2 (27) 2 325 H	MS5_3 (23) 2 325 H				

Multiple Impeller Styles:

	<p>Hydrofoil Impeller: For low viscosity flow controlled applications. Combines performance and high flow efficiency not found in other axial flow impellers.</p>
	<p>FP 100 Impeller (Marine Prop): Recommended for applications requiring moderate pumping action and powder-wetting capabilities.</p>
	<p>PBT Impeller: For low-to-medium viscosity flow controlled applications. Although superseded by the Hydrofoil, the PBT still has a specific role in applications where a degree of fluid shear is beneficial to the overall process result.</p>

Service kits available for rapid replacement of routine service items:

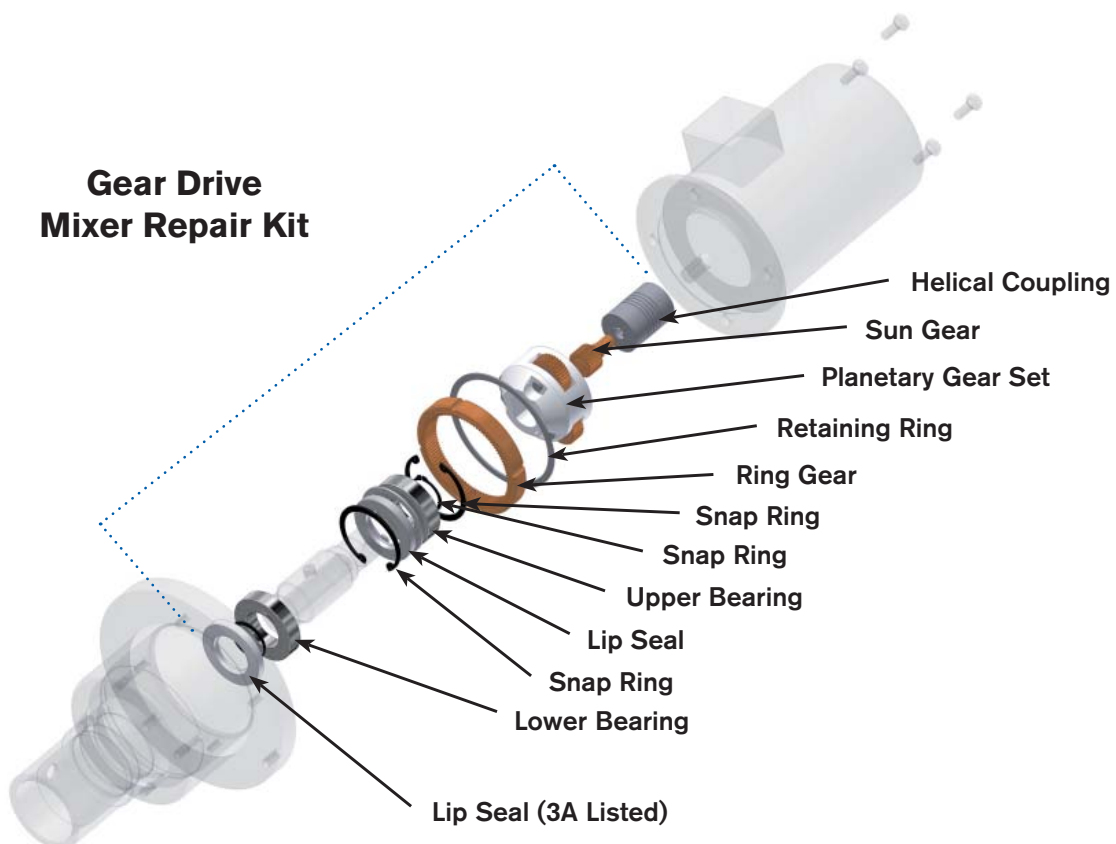

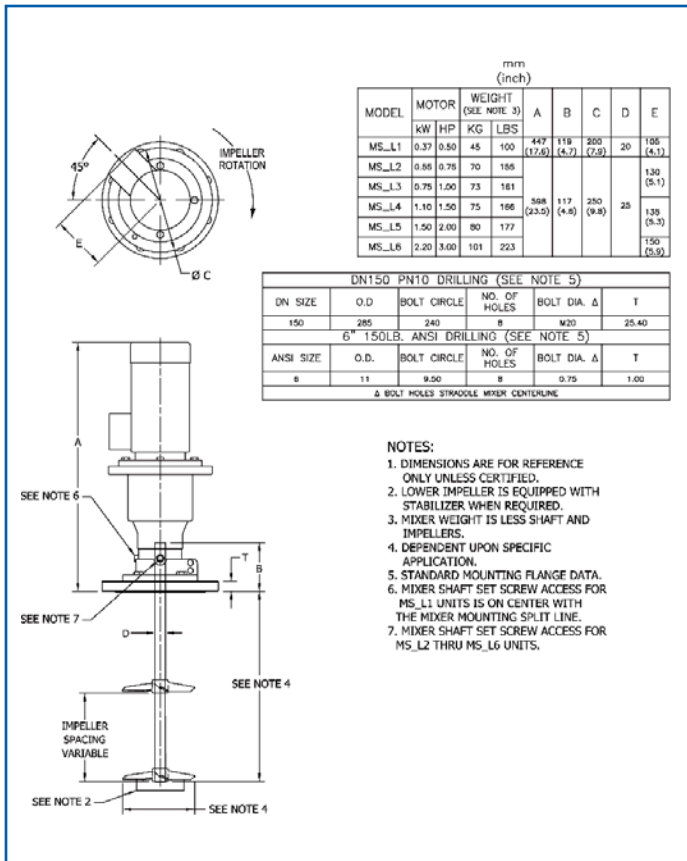

L Unit

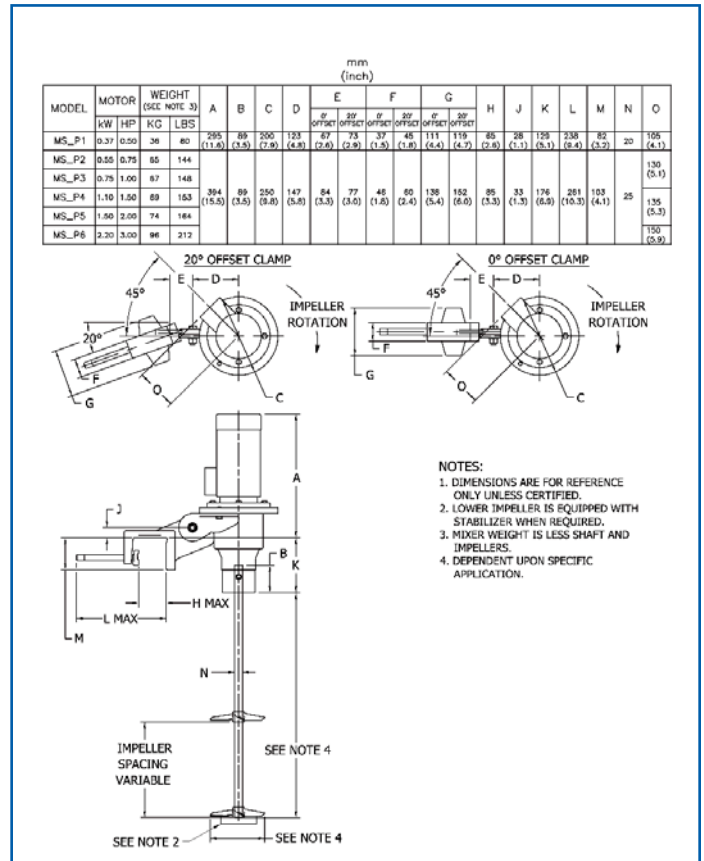

P Unit

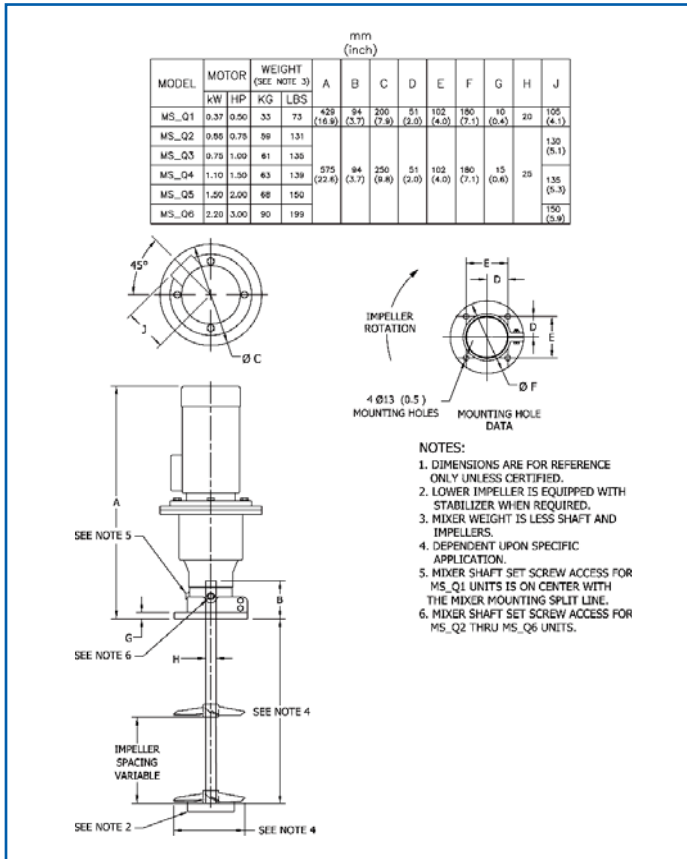

Q Unit

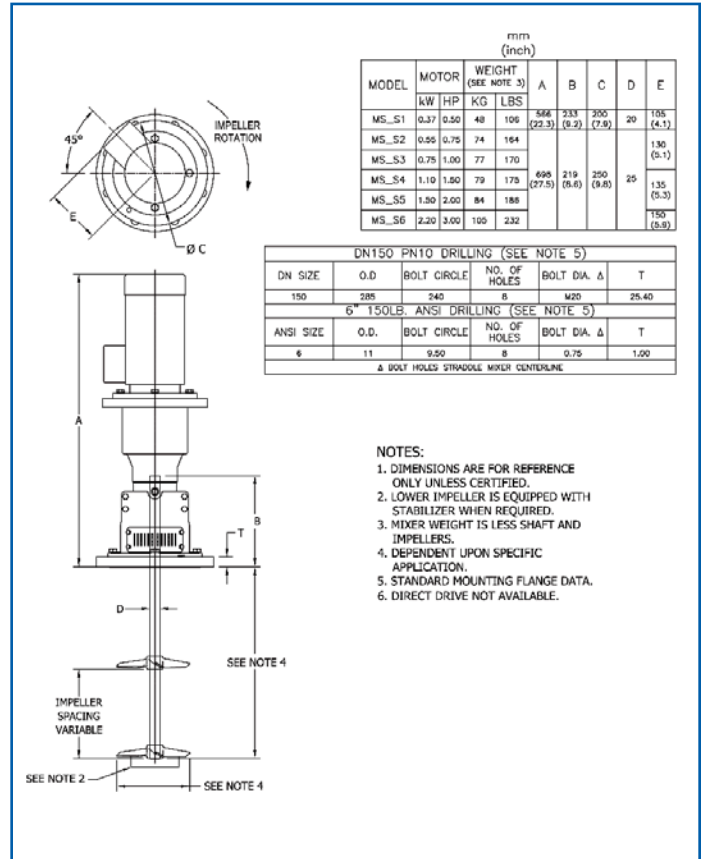

S Unit